

servicing
www.carburetorparts.com
the Carter
Aluminum
Four-Barrel
Carburetor

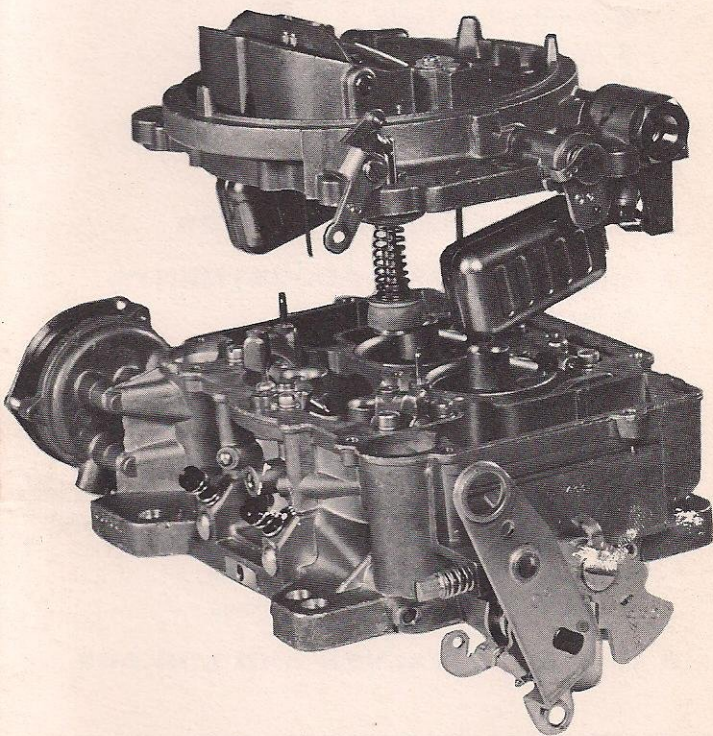

FOREWORD

This booklet contains a complete reprint of the discussion slidefilm, The Carter Aluminum Four-Barrel Carburetor.

Each man should have one of these booklets for on-the-job reference and at least one copy should be placed in the Service Department File of Technical Information.

CONTENTS

● DESCRIPTION	2
● Choke Clean Air System.....	3
● Choke Unloader.....	3
● Throttle Bore Vents.....	4
● Fuel Bowl Vents.....	4
● Hot Idle Compensator.....	4
● Throttle and Auxiliary Valves.....	5
● DISASSEMBLY	7
● CLEANING AND INSPECTION	10
● ASSEMBLY AND ADJUSTMENTS ...	12
● Float Alignment.....	15
● Float Level.....	15
● Float Drop.....	15
● Accelerator Pump.....	17
● Choke Piston and Linkage.....	17
● Fast Idle Linkage.....	18
● Fast Idle Throttle Valve Clearance.....	19
● Choke Unloader.....	19
● Secondary Throttle Valve Opening.....	19
● Secondary Throttle Valve Lockout.....	20
● THROTTLE VALVES AND LINKAGE	21

SERVICING

the **CARTER ALUMINUM**

FOUR-BARREL CARBURETOR



COPYRIGHT 1962 - CHEVROLET MOTOR DIVISION
GENERAL MOTORS CORPORATION

This film contains practical information which can be used when servicing the Carter Aluminum Four-Barrel Carburetor. The subjects covered are:

- DESCRIPTION
- DISASSEMBLY
- CLEANING AND INSPECTION
- ASSEMBLY AND ADJUSTMENTS
- THROTTLE VALVES AND LINKAGE

Although 1962 Chevrolet vehicles use five different models of the AFB carburetor, their appearance and operation are very similar.

Slight differences exist only in the calibration of fuel to air mixtures and arrangement of linkage.

Now, let's look at the application of these carburetors.

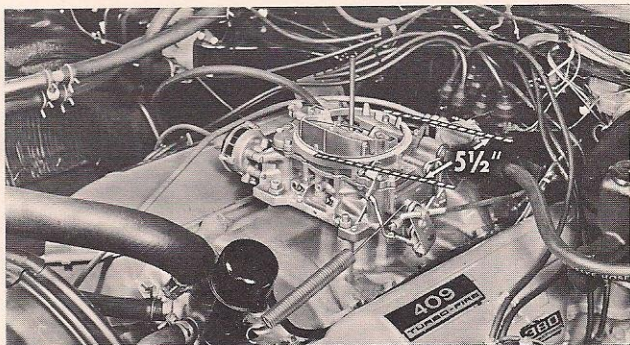

The 1962 Chevrolet passenger cars with the 409 cubic inch engine use Carter model AFB 3345SA, Chevrolet part number 3820580, as standard equipment. The air horn throat diameter is 5 1/2 inches.

FRONT

www.carburetor-parts.com

REAR

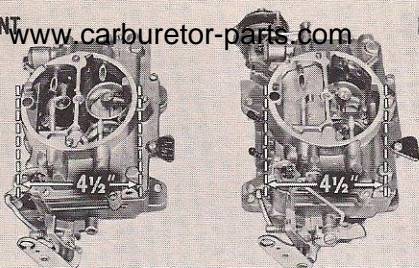

As a special option, the 409 cubic inch engine may be equipped with TWO AFB carburetors. The front model is 3361S and the rear model, containing a choke assembly, is designated 3362S. Both have air horn throat diameters of 4½ inches. Chevrolet part numbers are 3815403 and 3815404.

The High Performance 327 cubic inch engines, teamed with a 3- or 4-speed manual transmission, use AFB model 3269S as optional equipment while those with an automatic transmission use model 3310S as the available option. Both of these carburetors have an air horn throat diameter of 4½ inches and are very similar to the rear AFB model used on the 409 cubic inch engine equipped with TWO carburetors. Chevrolet part numbers are 3797699 and 3819207.

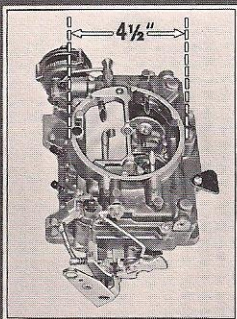

DESCRIPTION

The AFB Carter carburetor consists of two light aluminum castings. The section containing the metering rods, idle circuits, accelerator pump assembly and automatic choke system is called the primary side. The opposite section is called the secondary side. The primary side functions at all times while the secondary side stands by until top speed and power are needed. Let's examine some of the more important new features of the AFB carburetor before disassembly.

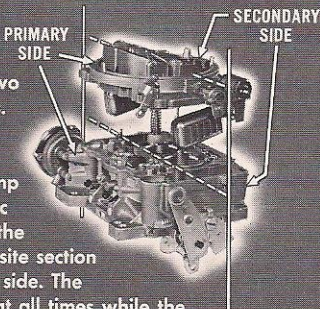

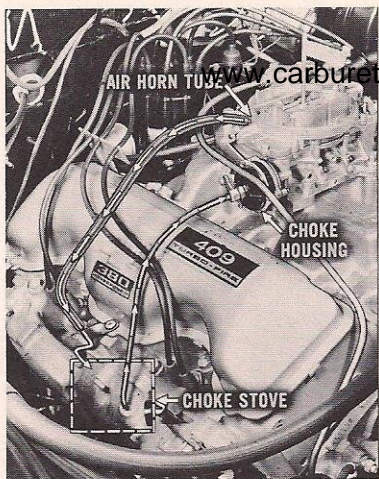

www.carburetor-parts.com

Choke Clean Air System: Air filtered through the air cleaner element is picked up at the air horn tube and pulled through the exhaust manifold choke stove into the choke housing.

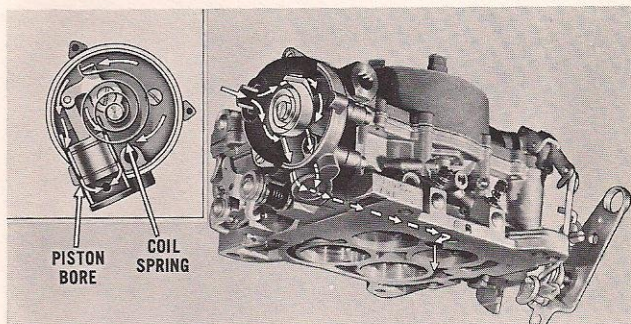

The heated air passes around the thermostatic coil spring and flows down the slotted sides of the piston bore before reaching the intake manifold vacuum source between the primary bores.

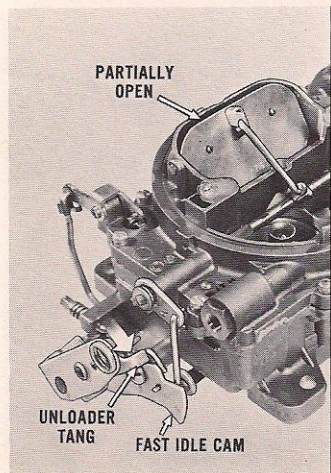

Choke Unloader: If the engine becomes flooded during a closed choke condition, a greater amount of air can be introduced into the intake manifold system by fully depressing the accelerator pedal. This action forces the unloader tang of the throttle lever against the fast idle cam and in turn partially opens the choke valve.

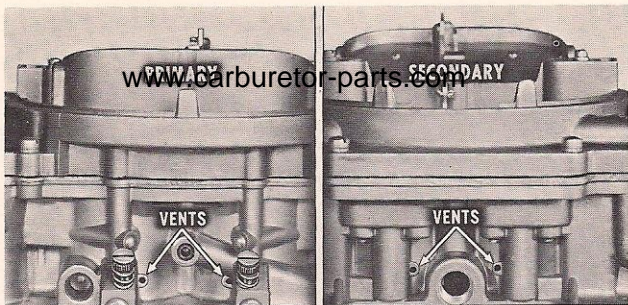

Throttle Bore Vents: To insure quick hot engine starting, four holes are drilled through the main casting body above the primary and secondary throttle valves. These vents in the primary and secondary sides of the carburetor permit any accumulated fuel vapors present in the bores to escape to atmosphere.

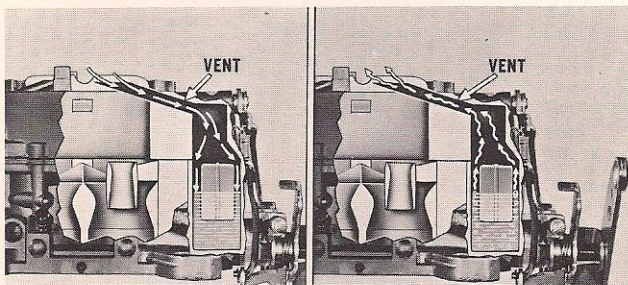

Fuel Bowl Vents: The vents perform two functions. They admit atmospheric pressure into the fuel bowls for proper carburetor operation. Also, when the engine is stopped and underhood temperatures greatly increase, fuel in the float bowls has a tendency to boil. The resulting fuel vapors escape through the vents rather than create a carburetor flooding condition.

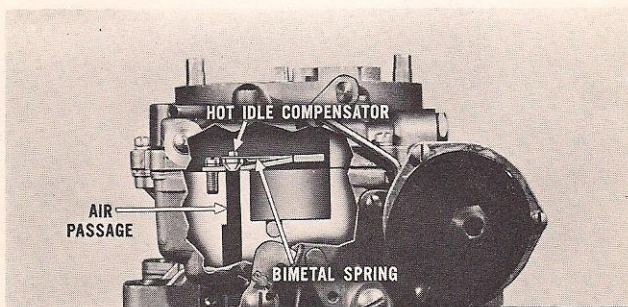

Hot Idle Compensator: This unit controls the opening and closing of a separate internal air passage in the carburetor main casting leading to the intake manifold. Throughout normal operating temperature ranges of the engine, the bimetal spring holds the valve tight to the seat.

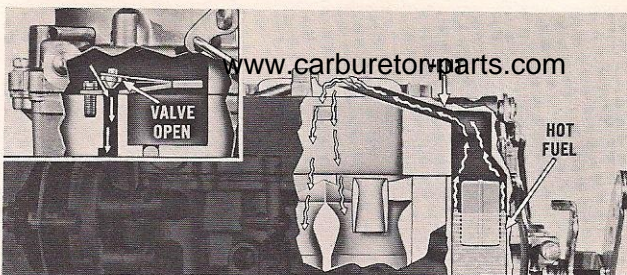

During high underhood temperatures at idle speed, the bimetal spring lifts the valve off its seat and permits additional air to enter the intake manifold. The leaner, more combustible mixture offsets a richer mixture formed when the high underhood temperatures cause fuel in the bowls to form vapors which enter the carburetor bores through the vents.

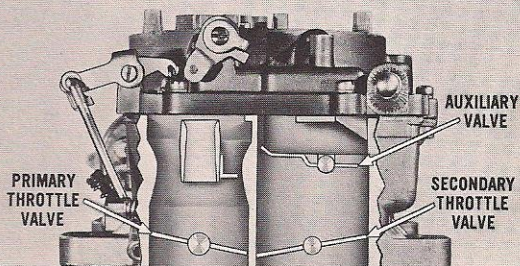

Throttle and Auxiliary Valves: Fuel and air flow of all AFB carburetors is controlled by the primary and secondary throttle valves and the auxiliary valves. The primary throttle valves function at all engine speeds regardless of the choke valve position. The secondary throttle valves function only with a wide open choke in the following manner.

When the choke valve closes, the fast idle cam pulls the lockout dog upward. This engages the notch on the lockout dog with the tang on the secondary throttle shaft, "locking" the secondary throttle valves in the closed position.

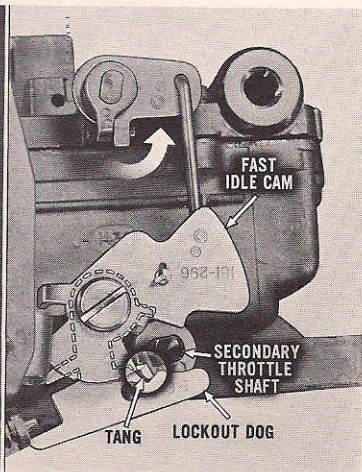

DISASSEMBLY

During disassembly and assembly, the majority of service procedures are photographed on the single AFB carburetor (5½" diameter air horn) used on the 409 cubic inch engine. However, when there are differences in construction among the five available AFB models which affect service procedures, these changes will be pointed out. Let's begin with the carburetor on the bench.

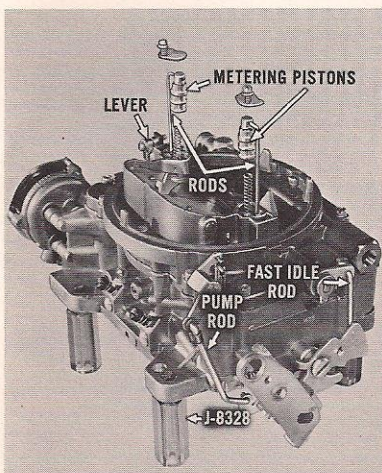

Support the carburetor on a suitable fixture or legs such as J-8328 to protect the throttle valves and linkage from damage. Remove the cover screws and plates holding the metering pistons, rods and springs to the air horn. Disconnect the upper end of the fast idle rod, the choke shaft clamp lever and the lower end of the accelerator pump rod.

Remove the pump pivot screw, pump arm and "S" link. Remove the fuel inlet fitting and gasket. Remove all air horn attaching screws. Note the length of the attaching screws for correct installation during assembly. Remove the air horn and the pump plunger. If the cover sticks, tap lightly with a soft-faced hammer. Never pry between gasket surfaces.

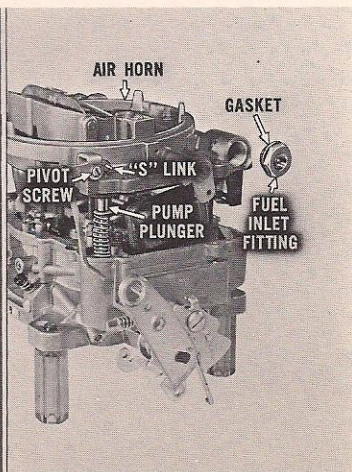

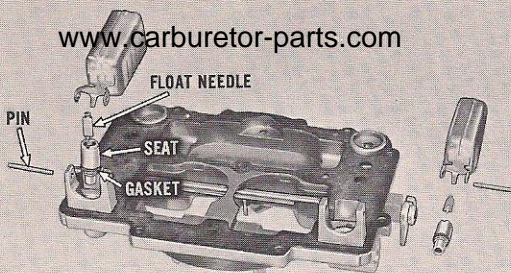

Invert the air horn and remove the float lever pins, floats, float needles, seats and gaskets. By keeping the parts for each float system together, only a minimum amount of adjusting will be necessary during assembly. Remove the air horn gasket.

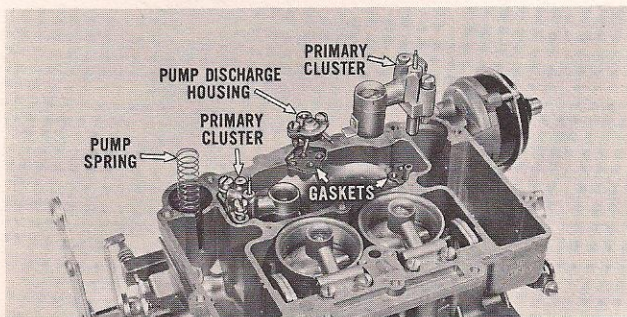

Remove the accelerator pump spring. Remove the primary venturi attaching screws, primary venturi cluster assemblies and gaskets. Remove the accelerator pump discharge housing attaching screws, housing and gasket.

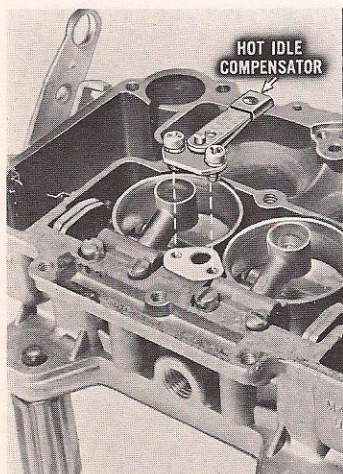

Remove the hot idle compensator and gasket. This unit is used on the rear carburetor of a 409 cubic inch engine equipped with TWO AFB carburetors and on both AFB models used on the 327 High Performance engines.

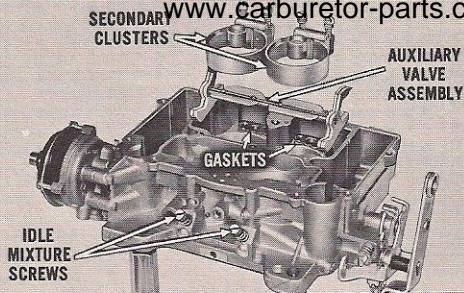

Remove the secondary venturi attaching screws, secondary venturi cluster assemblies and gaskets. Remove the auxiliary valve assembly by lifting straight upward. Remove idle mixture adjustment screws and springs.

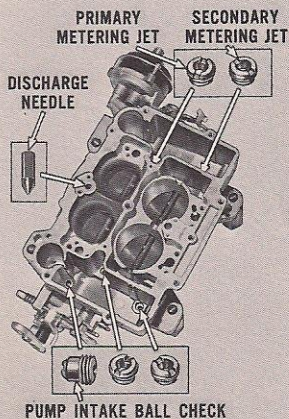

Remove the pump intake ball check assembly from the area adjacent to the accelerator pump cylinder. Remove the primary and secondary metering jets. Turn the casting upside down to remove the pump discharge needle. NOTE: The primary jets have larger holes to accommodate the metering rods.

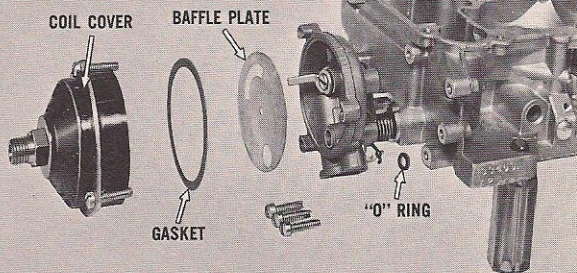

Remove the three screws attaching the choke thermostatic coil cover to the choke housing. Remove the gasket and baffle plate. Remove the choke housing attaching screws and separate the housing from the casting. Remove the small "O" ring seal.

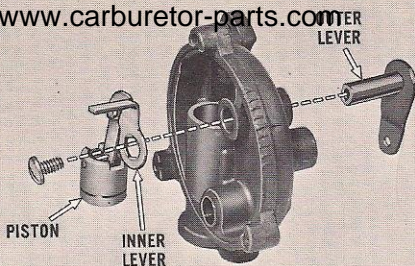

Remove the choke piston inner lever attaching screw. Separate the choke piston outer lever shaft from inner lever. Remove the choke piston and lever assembly.

For normal disassembly, cleaning and inspection, it is not necessary to remove the primary or secondary throttle valves or the choke valve assembly. However, if the shafts or valves bind or there is excessive looseness in the shaft bores, repairs should be made or new parts installed at this time.

Since this is not a common occurrence, the procedures are covered at the end of this presentation.

CLEANING AND INSPECTION

Wash all the carburetor parts and castings in clean commercial solvent EXCEPT the parts which are made of a composition material or plastic such as the accelerator pump and coil housing. Rinse all parts in kerosene. Blow out all passages and castings with clean compressed air.

Never use drills or wire to clean out fuel or air passages as this would enlarge the openings and affect fuel to air calibration.

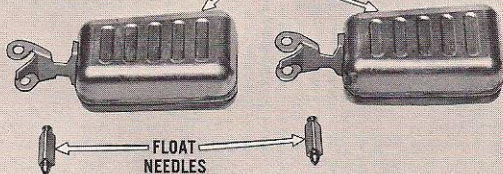

Shake floats to determine if fuel has leaked inside. Replace if necessary. Visually inspect float needles for signs of defects. Any history of leakage between the needle and seat, causing a flooding condition, should be corrected with new matched needle and seat assemblies.

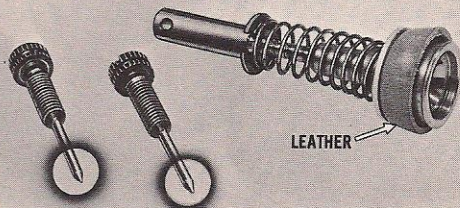

Inspect the tapered sections of the idle mixture screws for grooves or ridges. Replace if worn or threads are damaged. Inspect the pump plunger leather for cracks or creases. Replace with a new pump assembly if the leather is hardened, damaged, or shows signs of excessive wear.

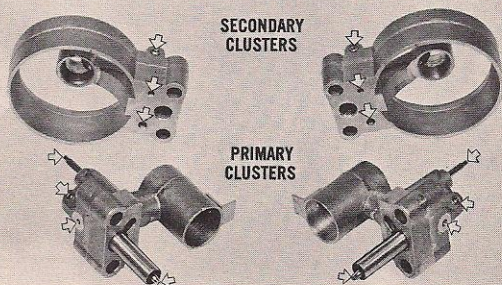

Carefully inspect the primary and secondary venturi clusters. Make sure there is no lint or foreign material obstructing the openings. If any of the preassembled parts are loose, bent or damaged, replace with a new cluster assembly.

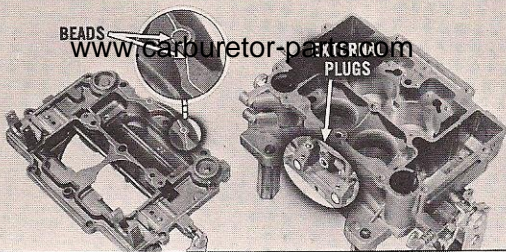

Inspect the gasket sealing beads and casting surfaces for nicks or damage. Inspection of the old gasket will help to determine if there is warpage of the matching surfaces. Small nicks should be smoothed down. Make sure all external plugs tightly seal the openings drilled into the casting during the manufacturing process.

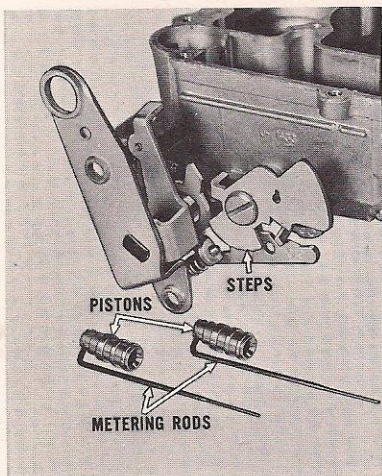

Check the steps on the fast idle cam for excessive wear and all movable linkage parts for an out-of-round condition or enlargement of the pivoting holes. Inspect vacuum-operated pistons and metering rods for damage. Replace parts as necessary to insure proper operation of the carburetor.

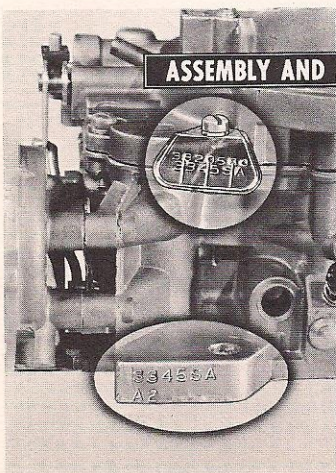

ASSEMBLY AND ADJUSTMENTS

Use all new gaskets and replace worn or damaged parts which were found during inspection. When ordering parts, it is important to refer to the CODE number stamped on the mounting flange or on the identification tag since many parts used among the various AFB carburetors look alike and fit but will not function properly.

Install the auxiliary valve assembly. This assembly must freely open and close without binding. Install the primary and secondary metering jets. The primary jets have the larger holes. Install the pump discharge needle and housing. Use a new gasket. Install the pump intake ball check assembly.

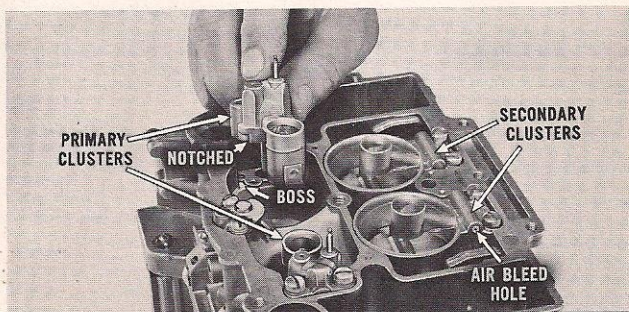
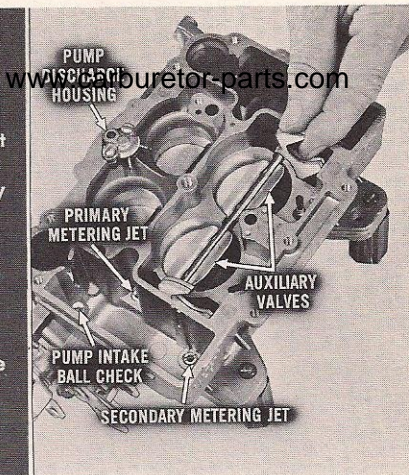

Install the primary and secondary venturi clusters with new gaskets. The primary clusters are notched to align with the boss in the casting. The secondary clusters are correctly installed with the air bleed holes (horizontal bronze housings) pointing toward the outside of the casting. Tighten attaching screws securely.

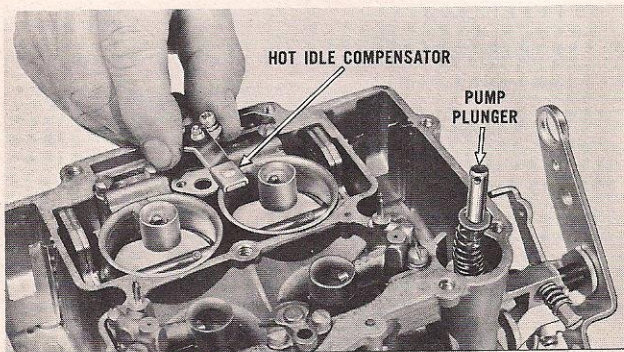

If the carburetor is equipped with a hot idle compensator, install this unit with a new gasket at this time. Install the accelerator pump spring and pump plunger.

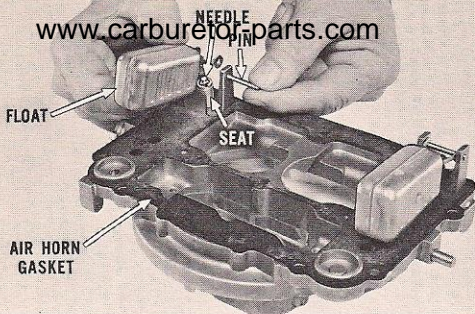

Install a new air horn gasket over the casting. Install the float seats with new gaskets and the floats, needles and pins.

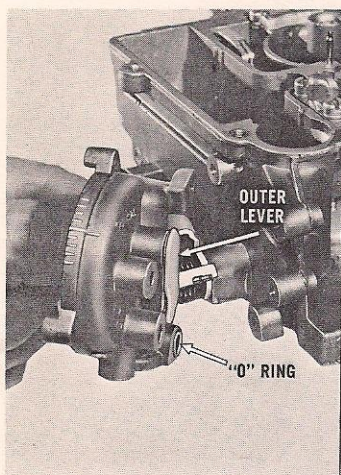

Install the choke piston outer lever in the choke housing. Insert the choke piston in the bore and attach the piston inner lever to the outer lever with the screw. Position a new "O" ring seal in the housing and attach the unit to the casting with the three screws.

At this point of bench assembly, we will begin checking and if necessary adjusting the:

- Float Alignment
- Float Level
- Float Drop

NOTE: Under certain conditions it may be advantageous to perform these service adjustments without removing the carburetor completely from the engine. A protective cloth stuffed into the primary and secondary bores will prevent parts from falling into the intake manifold system during the removal and installation of the air horn throat.

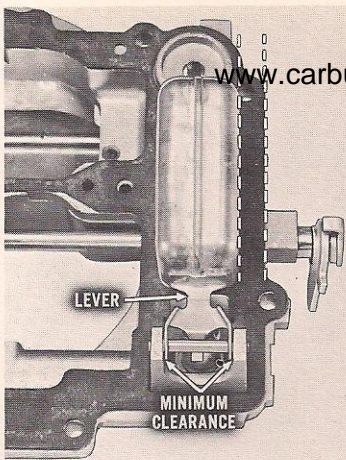

www.carburetorparts.com

Float Alignment:
 The ends of floats should be parallel to the casting edge. If necessary, bend the float lever by applying finger pressure to the end of the float shell while supporting the float lever with the thumb. The float lever arms should have a minimum clearance between lugs without binding. If necessary, bend arms. Check floats for free movement.

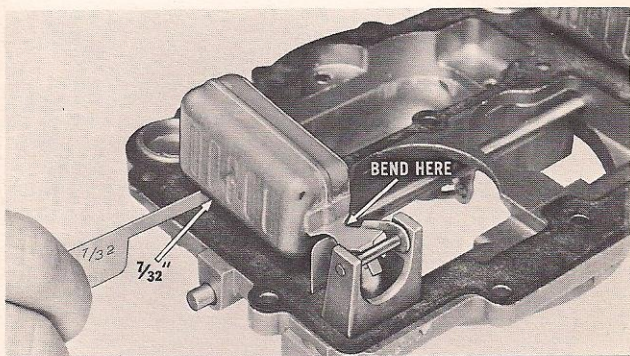

Float Level: Clearance between the air horn gasket surface and the top of the floats at their outer ends should be $\frac{1}{32}$ ". Adjust by bending the float levers at the location shown. Recheck float alignment.

Float Drop: Hold air horn throat casting upright and measure the distance from the outer end of each float at the top section and the air horn gasket. Correct distance is $\frac{23}{32}$ ". Adjust by bending the stop tab on the float arm.

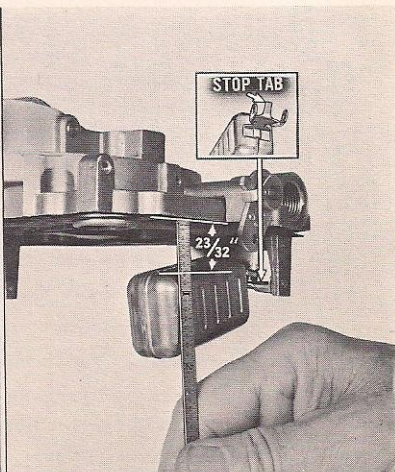

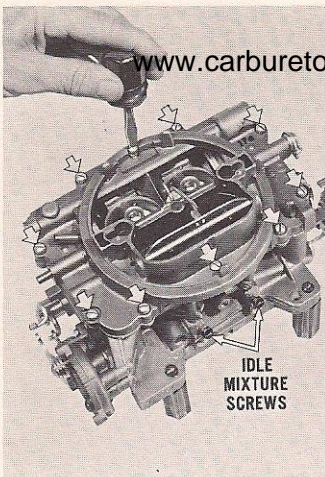

Carefully install the air horn assembly on the main casting. Guide the accelerator pump plunger shaft through the opening in the air horn. Install the air horn attaching screws snugly; then stagger the final tightening sequence. Install idle mixture screws and springs.

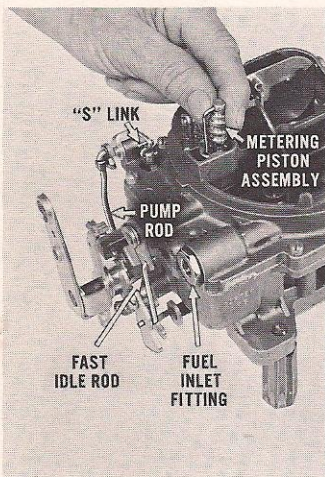

Install the pump "S" link, pump arm and the attaching screw. Install the pump rod to the pump arm and throttle lever with the spring clip and snap retainer. Connect the fast idle rod and install the spring clip. Install fuel inlet fitting with a new gasket. Install metering piston assemblies.

Each of the following service procedures may also be performed without removing the carburetor from the engine. In either case, maximum efficiency of the carburetor can only be achieved by checking and if necessary making adjustments in the order listed:



- Accelerator Pump
- Choke Piston and Linkage
- Fast Idle Linkage
- Fast Idle Throttle Valve Clearance
- Choke Unloader
- Secondary Throttle Valve Opening
- Secondary Throttle Valve Lockout

Accelerator Pump: Back off the idle speed screw until the primary throttle valves are fully closed. Hold the choke valve wide open and measure from the bowl cover to the top of the pump plunger. If the measurement does not read $\frac{1}{2}$ " , bend pump connector rod at the lower angle.

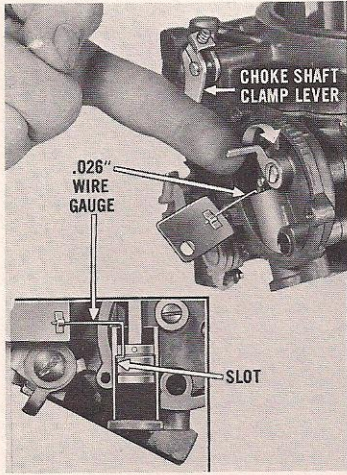
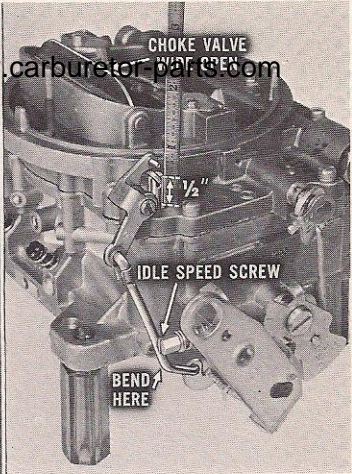

Choke Piston and Linkage: Connect the choke shaft clamp lever and rod. Insert the bent portion of a .026" wire gauge (part of J-9550 gauge set) in the top section of the slot cast into the choke piston bore. Slowly rotate the choke inner piston lever clockwise until the gauge is held tightly in the top of the slot by the piston. Hold this position and proceed as follows.

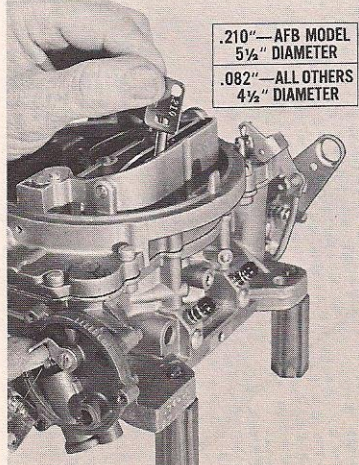

.210"	—AFB MODEL
$5\frac{1}{2}$ "	DIAMETER
.082"	—ALL OTHERS
$4\frac{1}{2}$ "	DIAMETER

Measure the distance between the top of the choke valve and the air horn wall as shown. The choke opening should be .210" for the AFB model with a $5\frac{1}{2}$ " diameter air horn throat and .082" for all others with a $4\frac{1}{2}$ " diameter air horn throat.

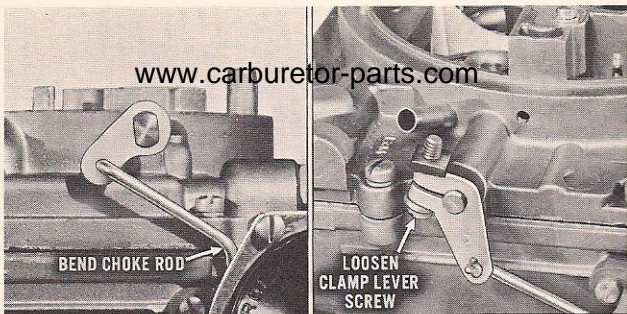

If the choke opening is incorrect on the 4½" diameter air horn models, bend the choke rod as necessary. On the AFB model with a 5½" diameter air horn, make the adjustment by loosening the clamp lever screw. Then rotate the lever on the shaft. Tighten the screw and recheck choke opening.

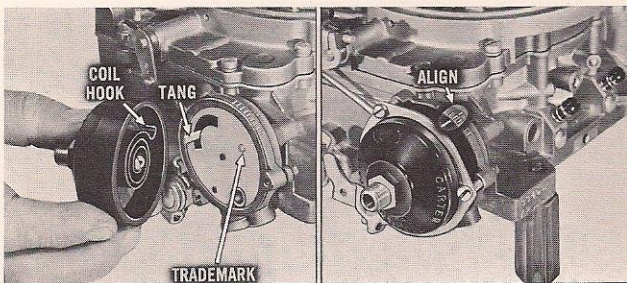

Install the choke baffle plate with the trademark "C" facing outward and place the gasket in position. Install the choke cover so that the coil hook engages with the tang on the choke piston inner lever. Loosely install retainer with screws. Then, rotate the cover clockwise to align the index mark with the middle mark on the housing and tighten screws.

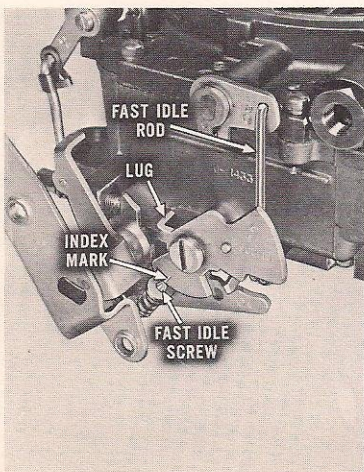

Fast Idle Linkage:
With the choke valve closed, note the alignment of the fast idle cam index mark with the fast idle adjustment screw. If necessary, bend the fast idle rod at its lower angle. After bending, recheck alignment. It may be necessary to bend the stop lug on the fast idle cam.



Fast Idle Throttle Valve Clearance: With the choke valve tightly closed, turn the fast idle adjustment screw to obtain a .015" to .018" clearance between the lower edge of the primary throttle valves and the bores opposite the idle ports. **NOTE:** It may be necessary to reset fast idle speed on the car to obtain 1700 r. p. m. with hot engine and screw opposite cam index mark.

Choke Unloader: Firmly rotate the throttle lever fully clockwise until the unloader tang kicks the fast idle cam downward. Clearance between the upper edge of the choke valve and the inner wall of the air horn should be $\frac{1}{4}$ ". If necessary, bend the unloader tang on the throttle lever to obtain correct choke opening.

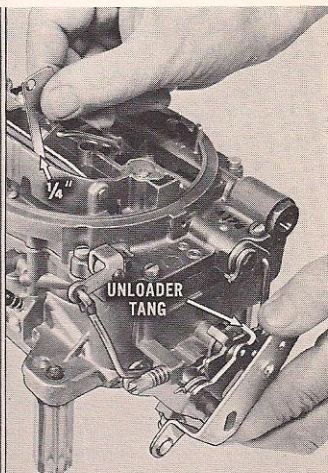

Secondary Throttle Valve Opening: Block the choke valve and auxiliary valves wide open. Rotate the throttle lever until the primary and secondary throttle valves are fully open. The stops on both the primary and secondary throttle levers should contact the casting lugs as shown. In this position —

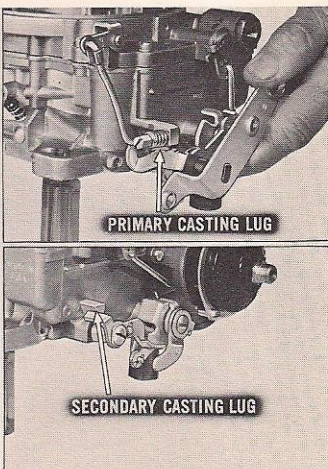

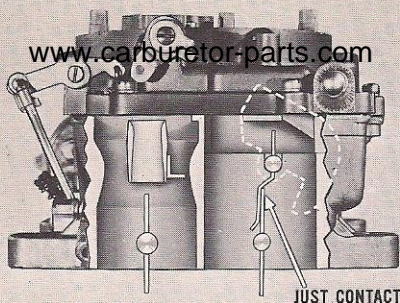

—the upper edge of the secondary throttle valves should just contact the fully opened auxiliary valves. If necessary, bend the stop on the secondary throttle lever to achieve the proper opening of the secondary throttle valves.

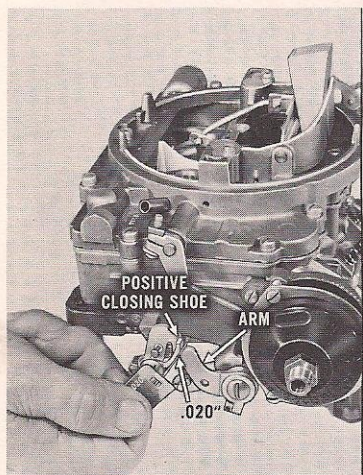

With the choke blocked wide open, close the primary throttle valves tightly. There should be a .020" clearance between the positive closing shoe of the secondary valves and the primary throttle shaft arm. If necessary, bend the positive closing shoe to obtain correct clearance.

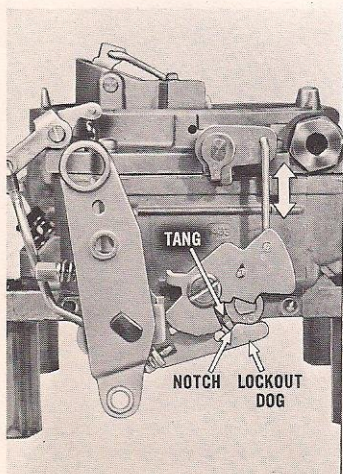

Secondary Throttle Valve Lockout: Open the primary throttle valves slightly. Slowly open and close the choke valve. The tang on the secondary throttle shaft should freely enter and engage in the notch of the lockout dog with a minimum of clearance. If necessary, bend the secondary throttle shaft tang. This completes normal overhaul procedures.

THROTTLE VALVES AND LINKAGE

www.carburetor-parts.com

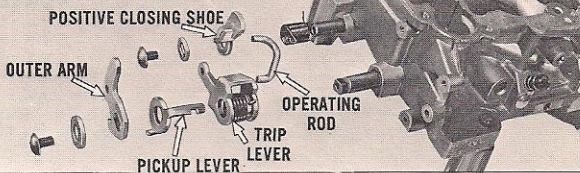

Although service is rarely necessary, the following information will help to correct a binding or sloppy condition of these parts. Remove the "V" shaped secondary throttle operating rod, the positive closing shoe, special washer and coil spring. Remove the primary throttle shaft outer arm, throttle shaft pickup lever, secondary trip lever and coil spring.

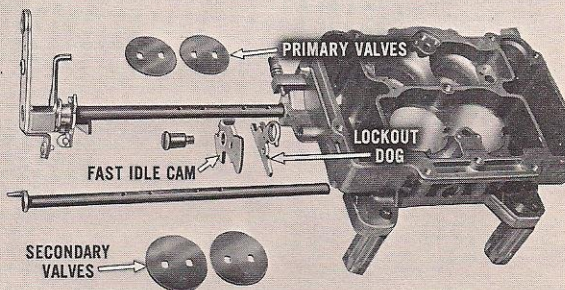

Remove the fast idle cam and lockout dog. File the peened ends of the throttle valve attaching screws; then remove the screws. Remove the primary and secondary throttle valves. Check throttle shafts for burrs at screw holes. Smooth off any roughness; then remove shafts.

To install new parts of the primary and secondary throttle valve assemblies and linkage, simply reverse the order in which the parts were removed. After installation of the primary throttle shaft and linkage parts, use a thin bladed screwdriver to pry the hook end of the coil spring into the notch of the secondary trip lever as shown.

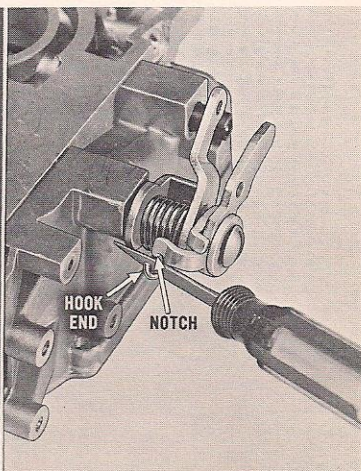

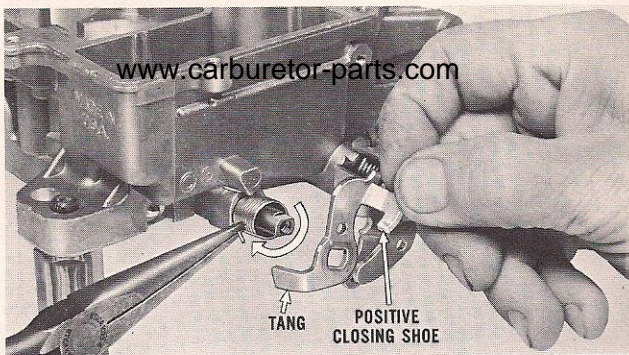

Wind the secondary throttle shaft spring clockwise $\frac{1}{2}$ turn and hook over the tang of the positive closing shoe. Install the balance of the parts and check for free operation.

Install the throttle valves with the trademark "C" (inside the small circle) facing the direction shown. Loosely install new attaching screws; then close the valves so they seat properly in the bores. Tighten the screws securely. Lightly upset screw ends to prevent them from falling out. Install fast idle cam and lockout dog. This completes throttle valve and linkage overhaul.

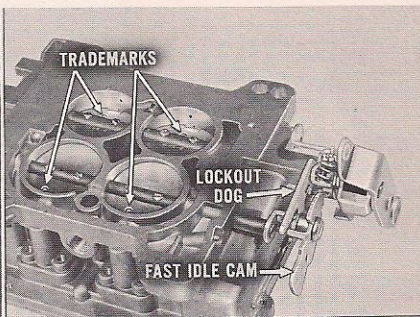

When installing the AFB carburetors on the 327 cubic inch High Performance engines, it is extremely important to position the gasket, the insulator and the steel baffle to the intake manifold as shown. The 409 cubic inch engine uses only the gasket.

