

New Interpretations of Motoring Luxury

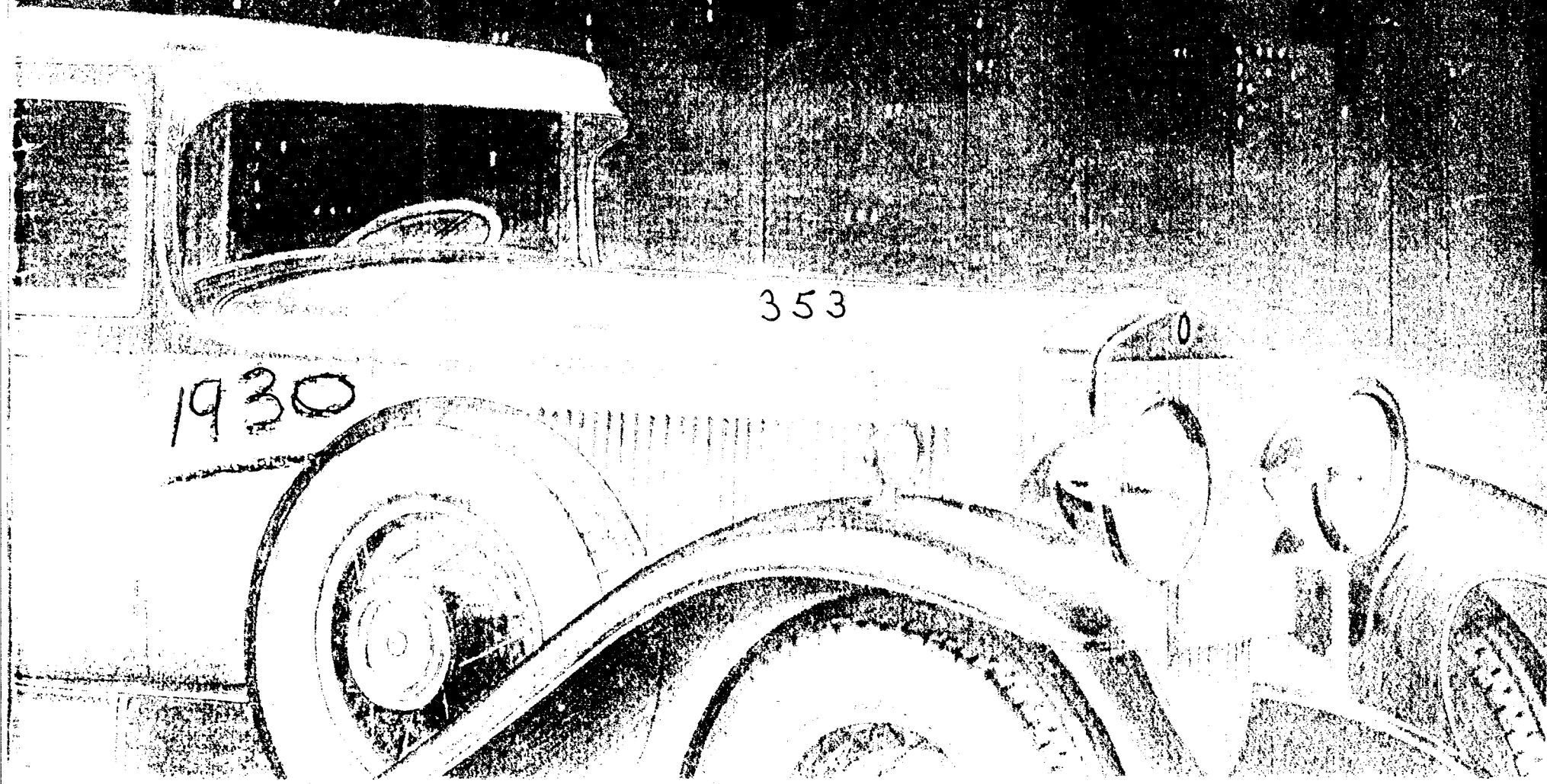

1930 Cadillac Brochure Front Cover

1930

P.R.
1930 - 6/12 - ✓

New Interpretations of Motoring Luxury

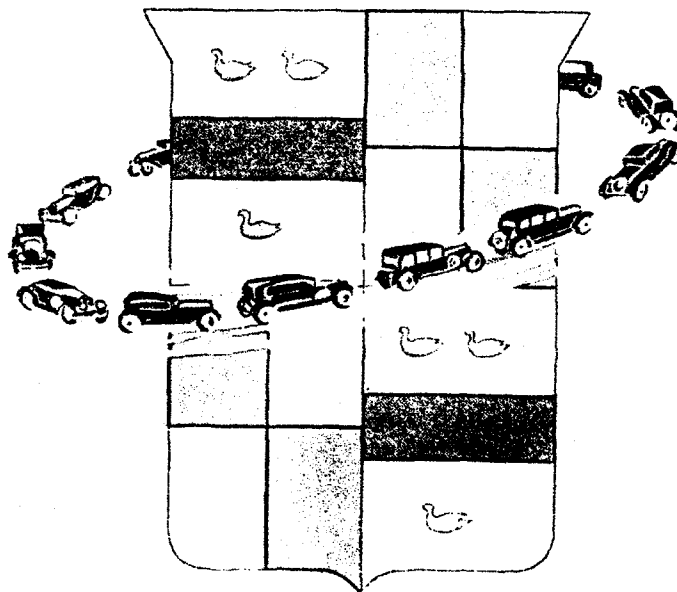

CADILLAC MOTOR CAR COMPANY • DETROIT

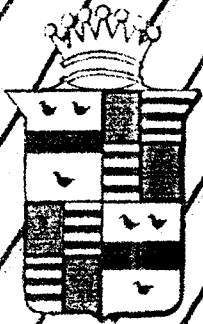

New Interpretations of Motoring Luxury

Newly styled throughout with fresh, vigorous beauty, and a wealth of contemporary smartness—roomier than ever—powered by an enlarged and refined V-type, eight-cylinder engine—vastly improved in flexibility, handling ease, and security—Cadillac's new models, here presented, easily take precedence over everything that fine cars have yet been.

The traditional excellence of Cadillac is in them in full measure. But it is an excellence brought fully up to the minute—refined and improved in every element of styling, powering, equipment, and control. They are the finest cars Cadillac has ever built—modern cars, measuring fully up to the exacting expectations of today's most discriminating motorists.

Their roominess is truly remarkable. Rear seats are abundantly wide—a full four inches wider than the delightfully roomy seats of previous Cadillac models. Three passengers

sit upon these cushions with the same uncrowded comfort as on a luxurious divan. The front compartment has the instrument panel recessed within the cowl to increase still further its generous length. Two bodies—the Seven-Passenger Sedan and the Seven-Passenger Imperial—are longer by three inches than Cadillac has ever before built them. But massive, luxurious, and roomy as these cars are, they reveal refinements in handling ease that are nothing short of amazing. To drive these Cadillacs at sustained high speeds over uneven roads involves no discomfort, no fatigue. Parking is easy. Maneuvering through traffic is a matter of deft directing, never of pulling the car about.

The solid reasons for owning a Cadillac, always weighty and impressive, are strengthened and multiplied by this new line. They inhere in every unit of these cars—in body, in engine, in chassis, in service facilities.



Many operations in building a Cadillac are held to extreme limits of accuracy. Skilled craftsmen check the gauges used throughout the plant by means of famous Johannson gauge blocks

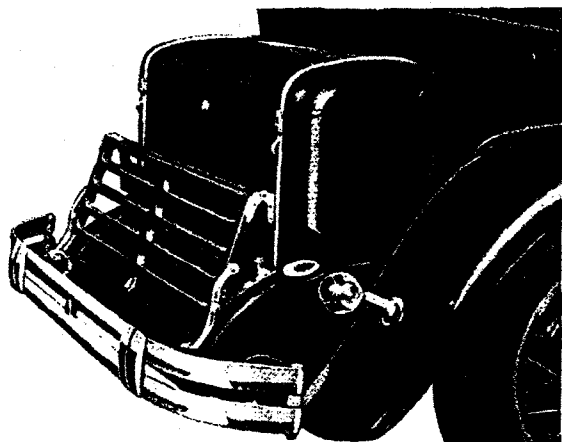

THE FIVE-PASSENGER TOWN SEDAN

Here is a model whose grace and individuality approach those of exclusive custom creations. Outwardly, it is distinguished by its window arrangement and by the commodious trunk at the rear. This is an all-metal, weatherproof, and dust-proof trunk made by Cadillac to harmonize with the body lines. Its beauty is enhanced by a facing of chromium-plated bars.

The interior, although spacious, is arranged for seating five passengers in an intimate group. This is obtained by a close-coupled body in which the rear seats, while providing ample leg room, are placed nearer the front seat than in usual practice. The leg room is supplemented by a cutaway under the rear of the front seat.

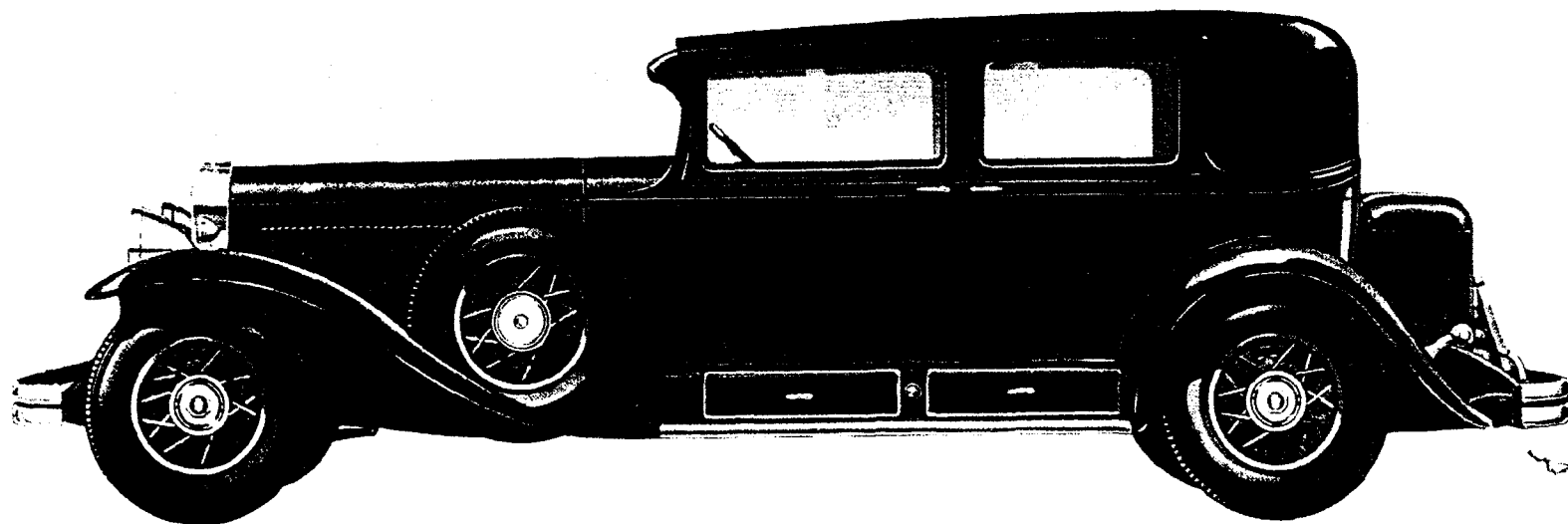

1-5-30

CAD. COPY # 26047

THE TWO-PASSENGER COUPE

The impressive length and pleasing proportions which have won outstanding popularity for this model are more than ever emphasized in this newest refinement. The cadet visor, wider radiator, enlarged lamps, and new rolled moulding effect along the rear deck, all enhance its pleasing charm.

Abundant room for three passengers is provided within the body, with a spacious deck seat for two additional passengers. The front seat is fully adjustable and the generous space allotment is still further increased by recessing the instrument panel under the cowl, which adds to the efficiency of the ventilating windshield. Equipment includes ash tray in the right door and a foot rest under the rear deck.

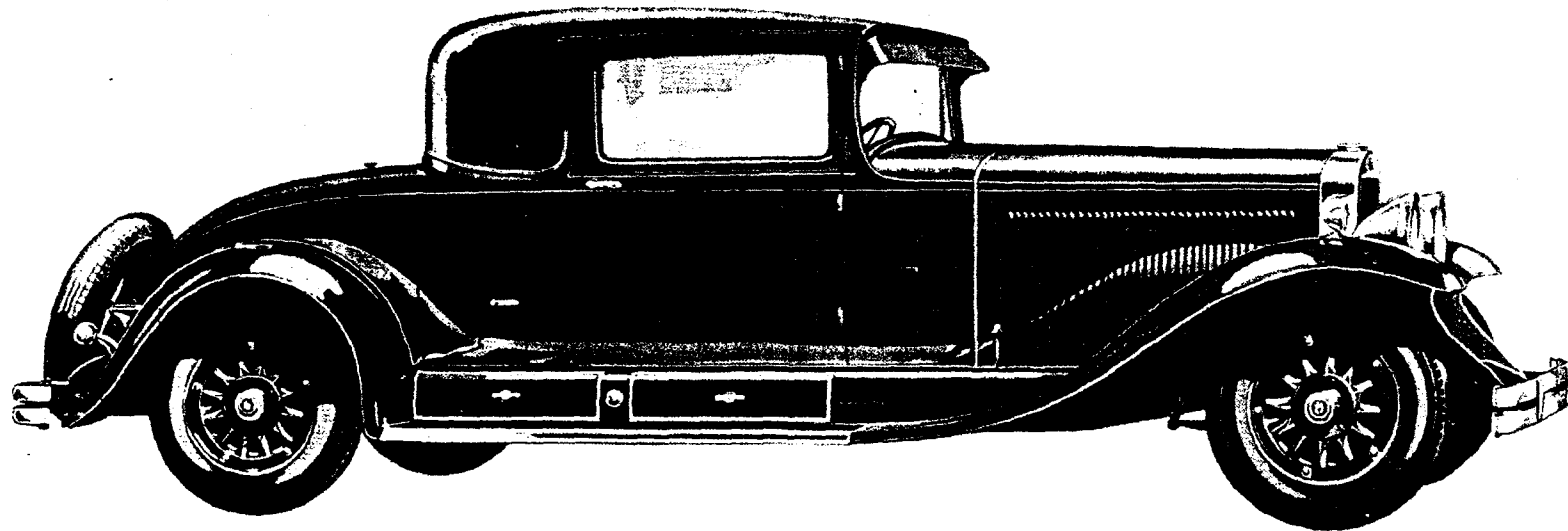
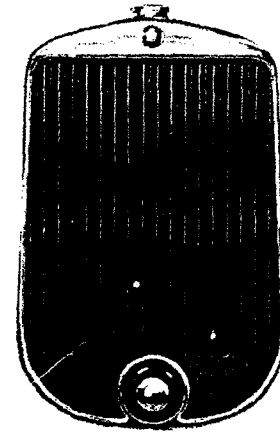

-5-

CAD COPY # 26048

AMPLE MARGINS OF SAFETY

Equally significant are the factors of greater safety introduced by these new Cadillacs. Today, when customary rates of travel upon the highways have increased far beyond what were but yesterday the maximum limits, the responsibilities imposed upon steering and braking systems multiply rapidly. The entire automobile industry has been intent upon these problems. Cadillac here solves them with characteristic thoroughness.

The steering system is completely harmonized. A special steering modulator, at the forward end of the left front spring, an unbreakable steering wheel, and a nitraloy steering sector are new features which combine to assure positive control. Even at the high speeds of which these cars are so easily capable, the steering system functions perfectly. And always there is a confident feeling of the



The pleasing lines of Cadillac cars are the results of the work of trained artists of the General Motors Art and Colour Section. They bring a new and fresh viewpoint to the problems of body design enhancing the beauty of one of our greatest necessities

utmost safety combined with positive and instant control.

Brakes, too, provide a very wide margin of safety beyond the intense demands of present-day traffic. They are a completely enclosed, weatherproof, shoe type and act smoothly, but positively and powerfully. Easy action is assured by mounting the operating

Every new Cadillac is conceived on the drawing board. Engineers design each part to perform its function, then the drawings are carefully considered before even a single experimental part is built



system in fifteen sets of roller bearings. Sure and instant control is assured by engineering features, which embody the best

thought of automobile engineers plus definite refinements exclusively developed by Cadillac.

These cars are abundantly powered with an engine of the same fundamental design as has made Cadillac dominant in the fine car field—the famous V-type, eight-cylinder engine. Not only is it substantially enlarged—from 341 to 353 cubic inches displacement—but its power output is still further increased by a new design of combustion chamber.

The Syncro-Mesh transmission, that epochal contribution to motoring ease, comfort, and safety, is retained, unchanged except for minor refinements in design.

Especially has care been lavished upon the appearance of the engine, which presents a remarkably trim assembly. Exhaust manifolds are brightly finished in a porcelain enamel, which is proof against the effects of heat and will preserve its luster indefinitely. Spark plugs are concealed beneath an ornamental cover plate. Wiring, too, is under cover within a shapely metal conduit, extending from the new distributor head to the spark plug cover.

THE FIVE-PASSENGER SEDAN

Combining outward beauty with exceptional roominess and comfort, the Five-Passenger Sedan attains the ultimate degree of luxury in transportation. There is a delightful sense of spacious freedom in this car. The width of the rear seat provides an abundance of room for three persons without crowding, and permits the use of arm rests with ease and comfort. When only two passengers use the rear seat, a disappearing arm rest may be pulled down from the center of the rear cushion.

The roominess of the front compartment is accentuated by recessing the instrument panel into the cowl. The front seat is fully adjustable for the driver's comfort.

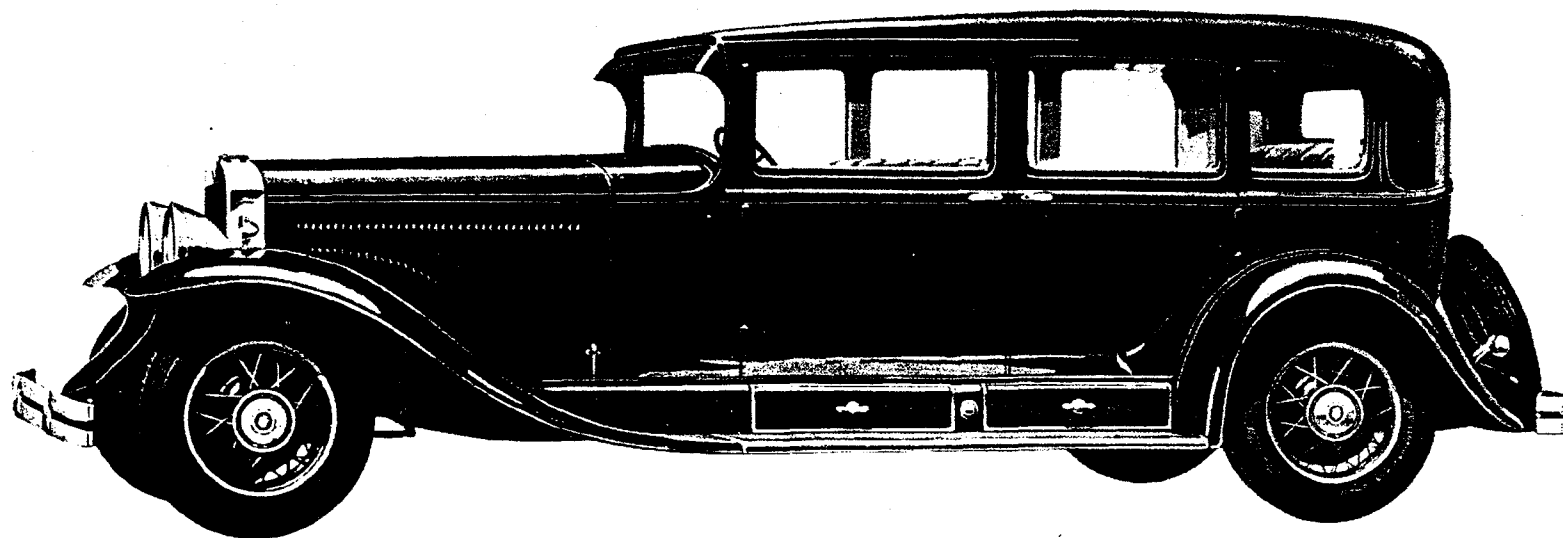
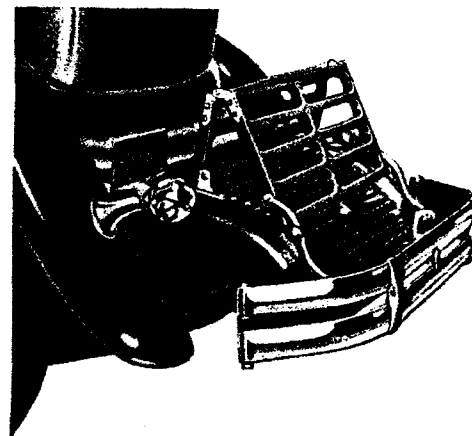

-7-

5 P-55 SEDAN

CAD. COPY # 19305

*CADILLAC-FLEETDOWNS
TWO-PASSENGER ROADSTER BY FLEETWOOD*

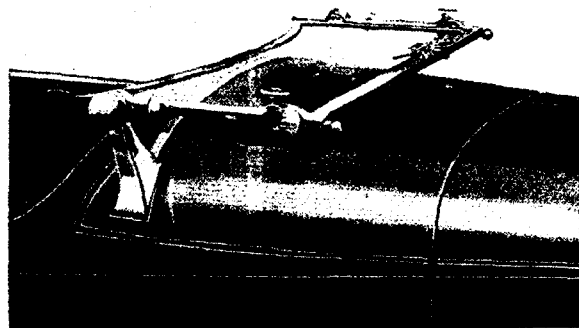

Here is an exceptional sport car abundantly capable of brilliant performance, smartly styled, and finely finished. The long graceful Fleetwood body has an unusually roomy deep-set seat. The top, smartly mounted on chromium-plated slats and ebony bows, lowers into a compact and attractive fold.

Three passengers find abundant room in the seat. The deck seat, too, is wider than in ordinary practice and, in addition, is equipped with arm rests and a foot rail.

The special folding windshield affords an extremely wide range of uninterrupted vision. Cowl louvers are a special feature on this model.

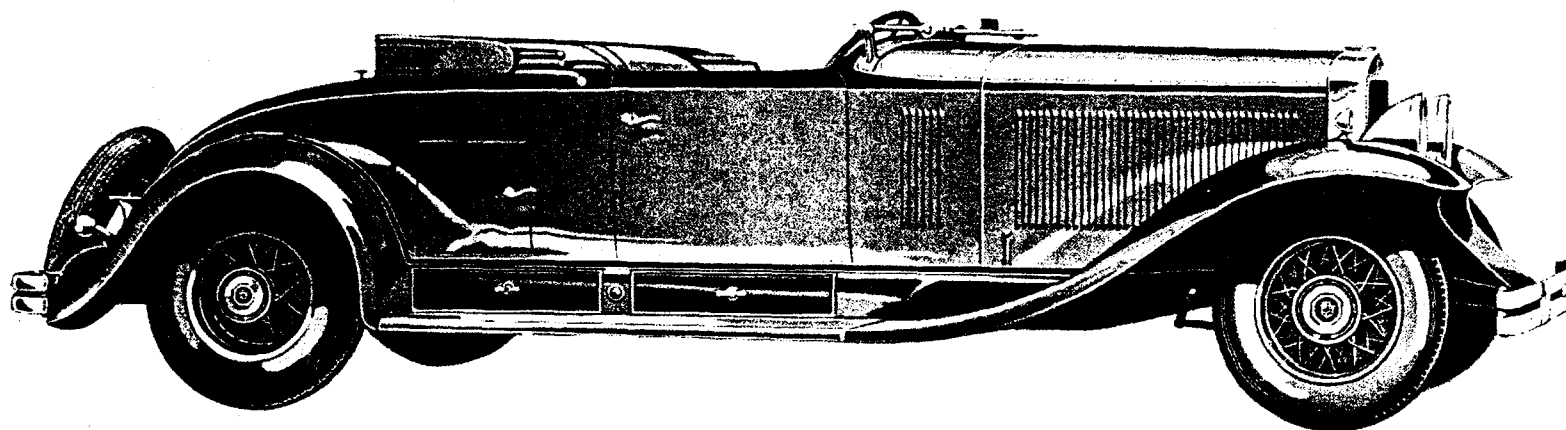

CAD. BODY # 22180

SUPREMACY IN COACHCRAFT

The new Cadillac is available in seven Fisher Custom bodies and fourteen Fleetwood Special Custom bodies. The wheelbase is 140 inches. The bodies are the most spacious and luxurious that Cadillac has ever offered.

The "Body by Fisher" emblem is everywhere accepted today as assuring the utmost degrees of excellence in body engineering, styling, and appointment. Upon these majestic bodies for the Cadillac line, all the wealth of Fisher manufacturing resources has been lavished without stint. The straight line moulding extending the full length of the car—the trim appearance at the cowl line—the gleaming curve of the side and quarter panels—the graceful valance at the rear, which covers the gasoline tank and frame members and joins smoothly into the rear fenders—these are touches of styling that lend instant distinction to these new and smart vehicles.



Full size clay models are prepared for the various body styles, so that Cadillac engineers may visualize a finished car before dies are made. This insures pleasing appearance and permits changes in design not otherwise possible

The spacious interiors are rendered even more inviting by the luxurious trimming in sumptuous fabrics—mohair, broadcloth, or whipcord. Metalware is a special design in bright silver by master silversmiths. Vanity cases are metal with inset trimming of the upholstery

Cadillac engines are developed in the Cadillac Research Laboratories where they are carefully tested and must prove their mettle before being released for production

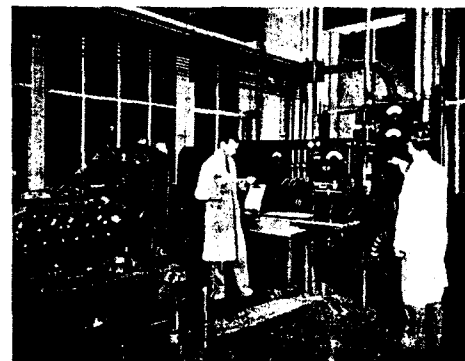

fabrics. The entire effect is that of a delightful drawing-room — complete, rich, luxurious, and in the very best of good taste.

The structure of these bodies reveals many special and exclusive features, all of which conduce to luxury in travel.

They are built of heavy eighteen-gauge steel for maximum rigidity and to provide a smooth surface, wholly free from waves, as a base for the Duco finish.

To assure the complete quietness of these bodies, they are sprayed inside with emulsified asphaltum before the trimming is put in. This preparation neutralizes any tendency of the body panels to act as sounding boards, and dampens minute noises before they can be magnified into severe rumbles. It is a further merit of this compound that it acts as an insulator of heat and helps to maintain an equable degree of temperature inside the body.

All metal parts throughout the entire body construction, including the frame and other parts of the chassis, are separated by an anti-squeak material, eliminating squeaks and rattles. Special rubber shims have been provided between the frame and body, forming a cushion which absorbs all noises. The body sills are strengthened to provide additional stability.

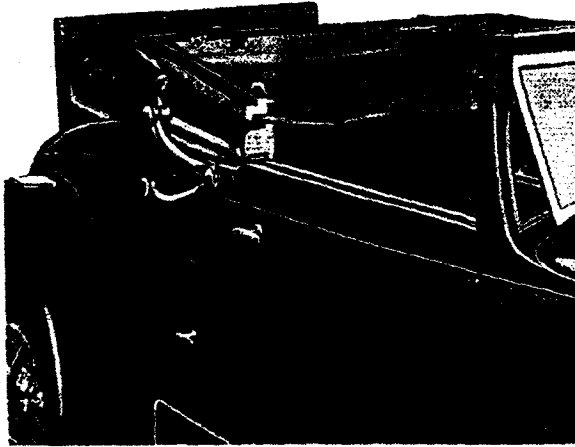

THE TWO-PASSENGER CONVERTIBLE COUPE

In this dual-purpose model, Cadillac achieves a most spirited interpretation of its fleetness, smartness, and luxury. Its distinctive feature is the fully collapsible top with an extra interior lining, which completely conceals the folding mechanism and top supports. Gracefully proportioned when up, folding into compact compass when lowered, this top is smart as well as highly practical. Related features are the chromium-plated window frames and windshield. The back curtain buttons into the top when desired.

The interior is exceptionally roomy and attractive, accommodating three passengers without crowding. The seat is fully adjustable. There is a foot rail for deck seat passengers.

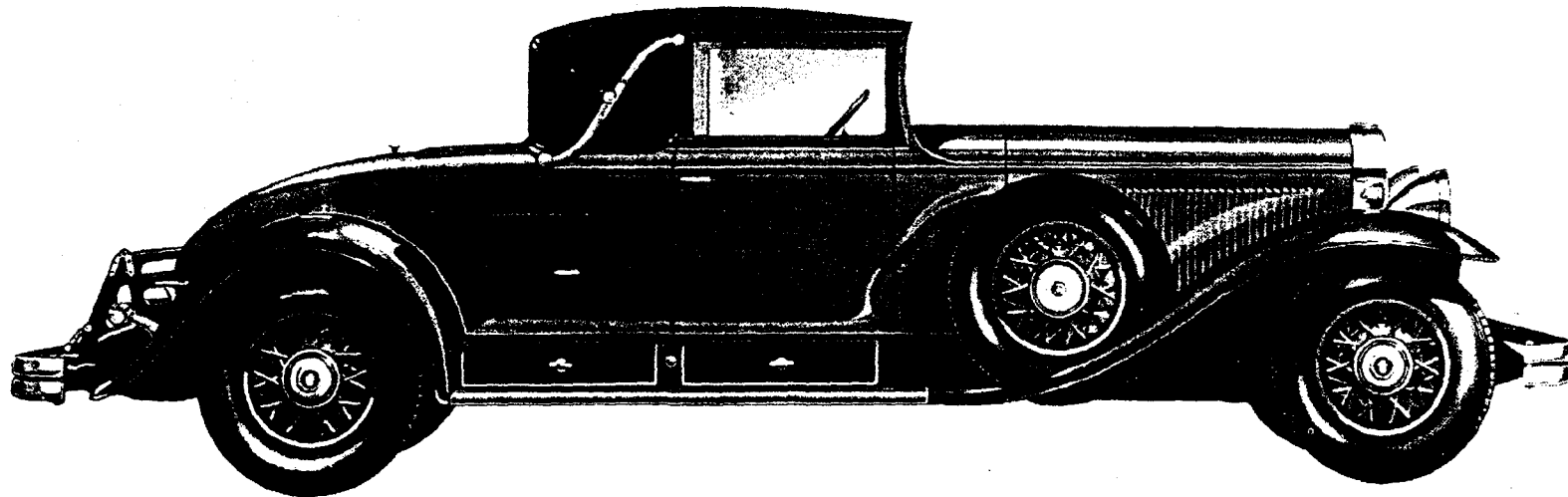

- 10

CDD. COPY # 19324

THE SEVEN-PASSENGER SEDAN

More than three inches longer in overall length than Cadillac has ever before made this model, this Sedan is an impressive interpretation of modern motoring luxury. The roomy rear seat has been made four inches wider, and both the rear seat and the auxiliary seats have an added measure of leg room.

Above all, it is a seven-passenger model abundantly and smoothly powered for its duties. The exceptional handling ease, riding comfort, and safety so noteworthy in the Cadillac chassis make it distinctive in the field of fine motor cars. And the comfort of its passengers is doubly assured by the use of springs especially fitted for this body type, supplemented by Duo-draulic shock absorbers.



8/10/38
30918

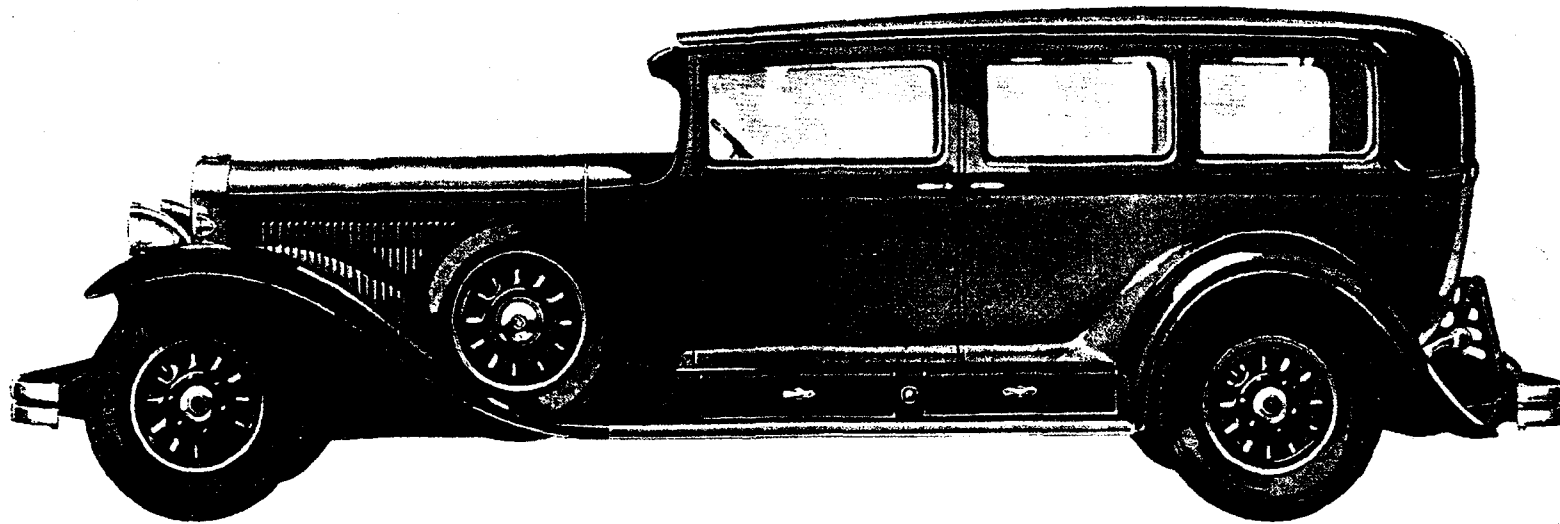

-11-

CAD. COPY # 19307

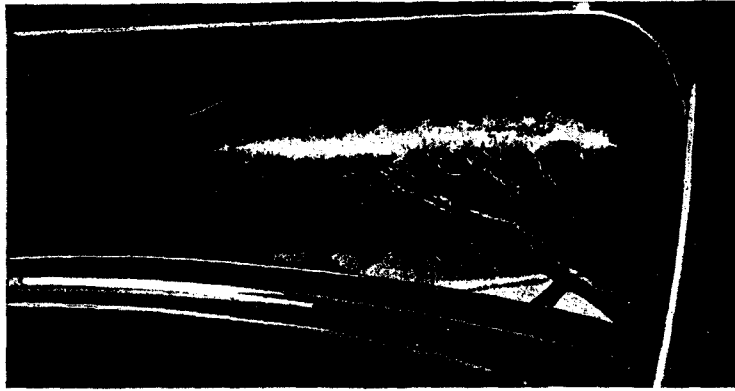

An example of the protection afforded by non-shatterable Security-Plate glass with which all windshields, doors, and windows on Cadillac cars are equipped. This windshield was hit by a bullet at close range but the bullet failed to penetrate the glass.

SECURITY-PLATE GLASS

Non-shatterable Security-Plate glass is used in the new Cadillacs for all windshields, doors, and windows. The safety feature of this glass for motoring today can hardly be overemphasized. For in the event of accident or collision Security-Plate glass will not fly into fragments. Instead, it stays intact and eliminates the hazard of injury from flying glass. Here is a factor of mental ease that no motorist will willingly do without.

The Fisher VV windshield is a new type which is inclined slightly from the vertical to deflect the glare from headlights of cars approaching from the rear. This feature gives the driver free vision in night driving.

Car roofs are formed from slats of selected wood two inches wide and placed one and one-half inches apart. This construction forestalls all weaving of the roof and provides for quietness at this point. To eliminate any possible noise, the slats are set on friction tape where they join the cross bars, and are held permanently in place at the front by strips of band iron. The side and quarter panels of the roof are covered with metal, giving a pleasing effect and adding considerably to the rigidity of the body. The central section of the roof is covered by a waterproof fabric.

Running boards, mouldings and many other bright metal parts are of stainless steel which will retain its luster indefinitely, will not mar easily, and adds a flashing beauty.

Improvements in many items of outward appearance enhance still further the rich beauty of these cars. Thus, the radiator is wider than before. Headlamps are larger. Deep outer flanges bring the fenders close over the wheels. And the slatted valance over the gasoline tank is gracefully joined to the rear fenders to give a fully tailored appearance. In short, every detail reveals that combination of artistry and coachcraft which is the true basis of beauty.

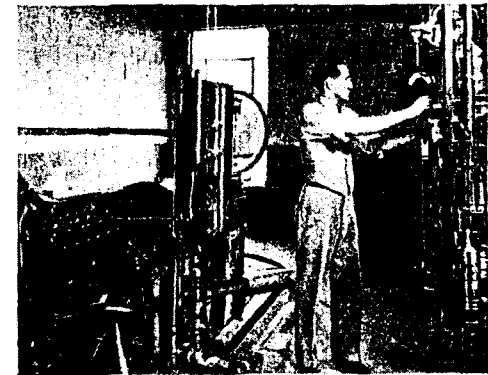

Many of the important developments pioneered by Cadillac have been conceived in the dynamometer rooms of the General Motors Research Laboratories by some of the most famous scientists in the industry

THE FIVE-PASSENGER COUPE

Long a preferred model for intimate personal uses in business or social affairs, the new Cadillac Five-Passenger Coupe achieves a more beautiful interpretation than ever. Its balanced and colorful outward grace is fully matched by its interior luxury.

Dome and corner lights are provided. Opening the door automatically turns on the dome light. The smoking set is equipped with a detachable, catalin-cased lighter, and two ash trays. The vanity case consists of a metal-covered mirror, memo book with silver pencil, and ash tray. Entrance and exit from the driver's seat have been made exceptionally easy by moving the control lever forward. The driver's seat is individually adjustable.

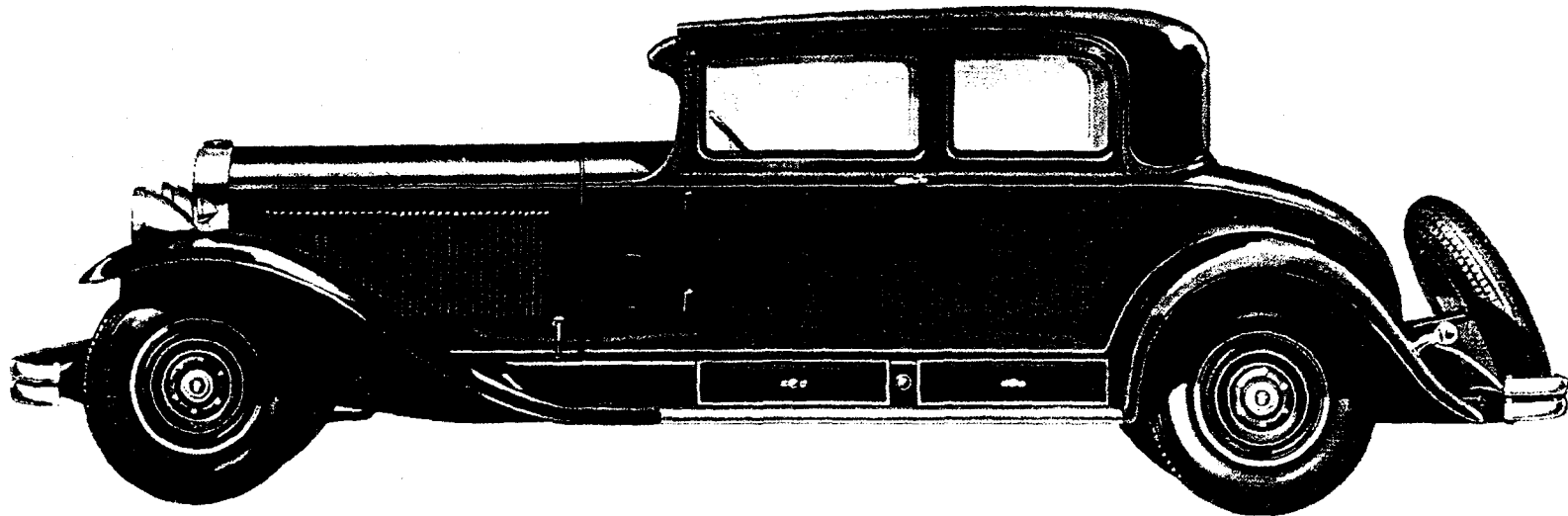
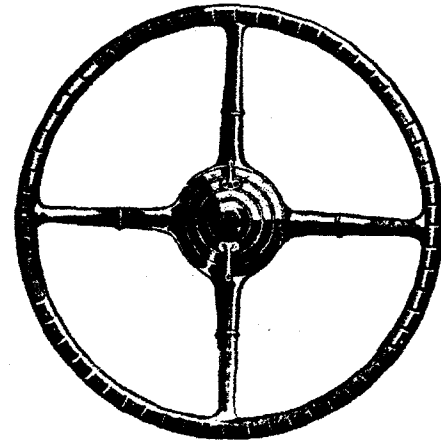

13 -

ead copy # 19309

THE SEVEN-PASSENGER IMPERIAL

As a recognized leader among the finest cars of the world, the Cadillac is inevitably in demand for use at formal functions. For such occasions, the Imperial is specifically designed. Its imposing length, accentuated by an impressive radiator, great headlamps, and the long, straight line of moulding, gives it a majestic presence that dominates every setting.

Three passengers in opera cloaks find an abundance of room in the rear seats, with generous clearance between them and the auxiliary seats. There is an inbuilt telephone for conversation with the driver.

The front compartment, set off by an adjustable glass partition, is upholstered in rich leather.

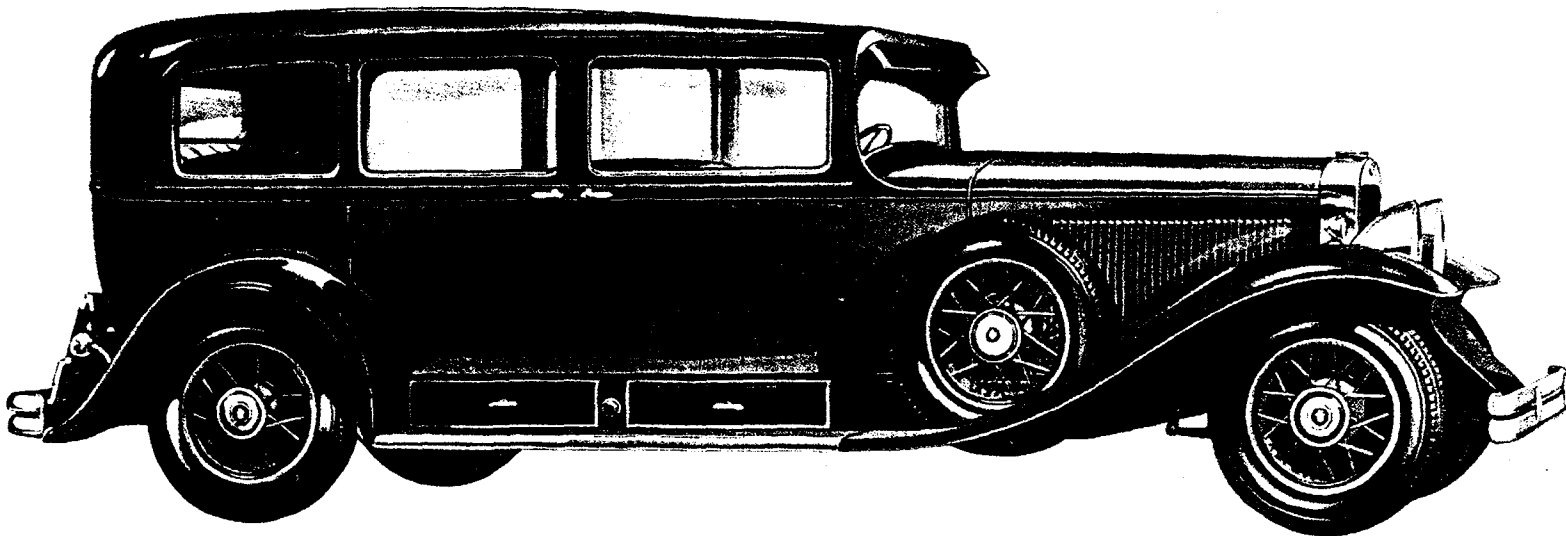
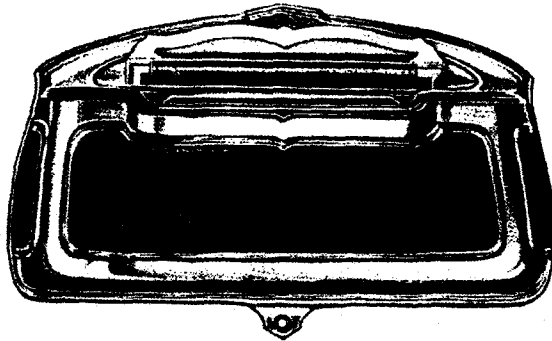

14-

CAD COPY # 26049

*CADILLAC-FLEETWAY
FOUR-PASSENGER ALL-WEATHER PHAETON BY FLEETWOOD*

The high sides with wide mouldings tapering to a distinct curve at the rear give this handsome model that distinctive touch that characterizes every Fleetwood Custom creation. Doors are mounted on a single central hinge. The rear compartment is unusually long.

The top is a full-folding type covered with burbank. There is a glass partition between compartments which can be used as an Imperial partition, as a tonneau windshield, or lowered completely out of sight.

The windshield is a distinctive V-type with chromium-plated supports. A specially designed Cadillac-built trunk is obtainable at extra cost.

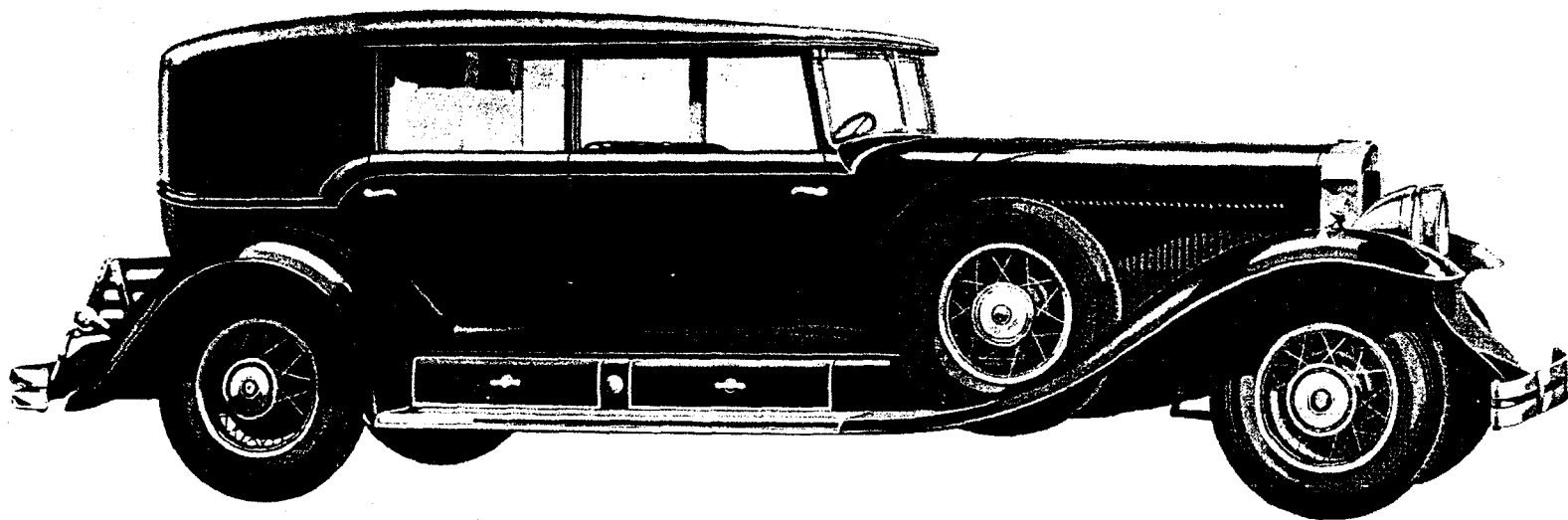
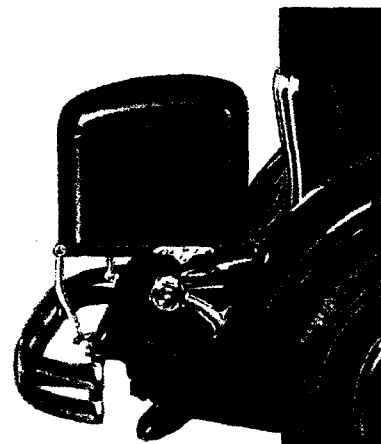

FLEETWOOD SPECIAL CUSTOM BODIES

Coachcraft by the Fleetwood Body Corporation has long been recognized throughout the industry for fine fashioning and sound construction. As built today exclusively for Cadillac-built cars, these bodies are the finest examples of the coach builder's art and reveal the utmost in style, individuality, exclusiveness, and luxury.

Two of the open cars are pictured and described in this book. For complete information, ask the Cadillac dealer for special Fleetwood literature.

A PREPROVED PRODUCT

These new models represent the combined efforts of the vast laboratories of General Motors working in close co-operation with Cadillac engineers to achieve the ultimate in fine car engineering.

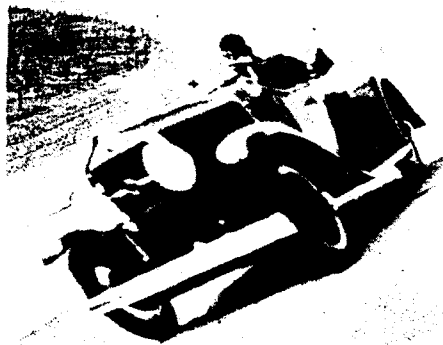

After the engine has proved its mettle it is placed in a test car and driven thousands of miles at high speeds at the General Motors Proving Ground, and faults in engine or chassis are readily revealed

Nothing has been lacking in precision methods. Nothing has been overlooked in mechanical equipment, finish, and appointments.

So ample, so smooth, so quiet is the power stream, that these new Cadillacs maneuver lightly and speedily with far more spirit than conventional lightweight cars can display.

FACTORY-DIRECTED SERVICE

The excellence of Cadillac service is everywhere recognized and emulated throughout the industry. A factory-directed standardized service plan and policy assures owners courteous, prompt, efficient service

at uniformly fair prices. This plan accords tourists the same privileges in all authorized Cadillac-LaSalle service stations as they would receive at home. The Cadillac Service Card, issued to the owner by the factory, entitles him to full consideration and care by every Authorized Cadillac Service Station for the full life of the policy. This service safeguards the owner's investment in his car and assures him that it will always be ready to deliver to him the brilliant and dependable performance of which it is so abundantly capable

The following pages describe in detail many of the structural units which make the Cadillac what it is. These are technical matters. But they are of vital significance to you. They give you complete mental ease in all your motoring.

Study these pages. Then drive a new Cadillac. Learn by personal experience just how all the features here pictured and described help to make your motoring safe, comfortable, and wholly enjoyable.

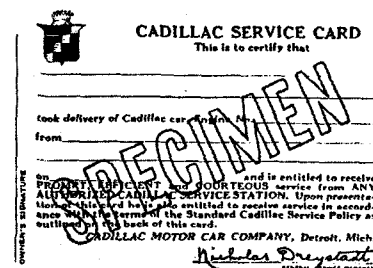

A Cadillac service card

MECHANICAL FEATURES

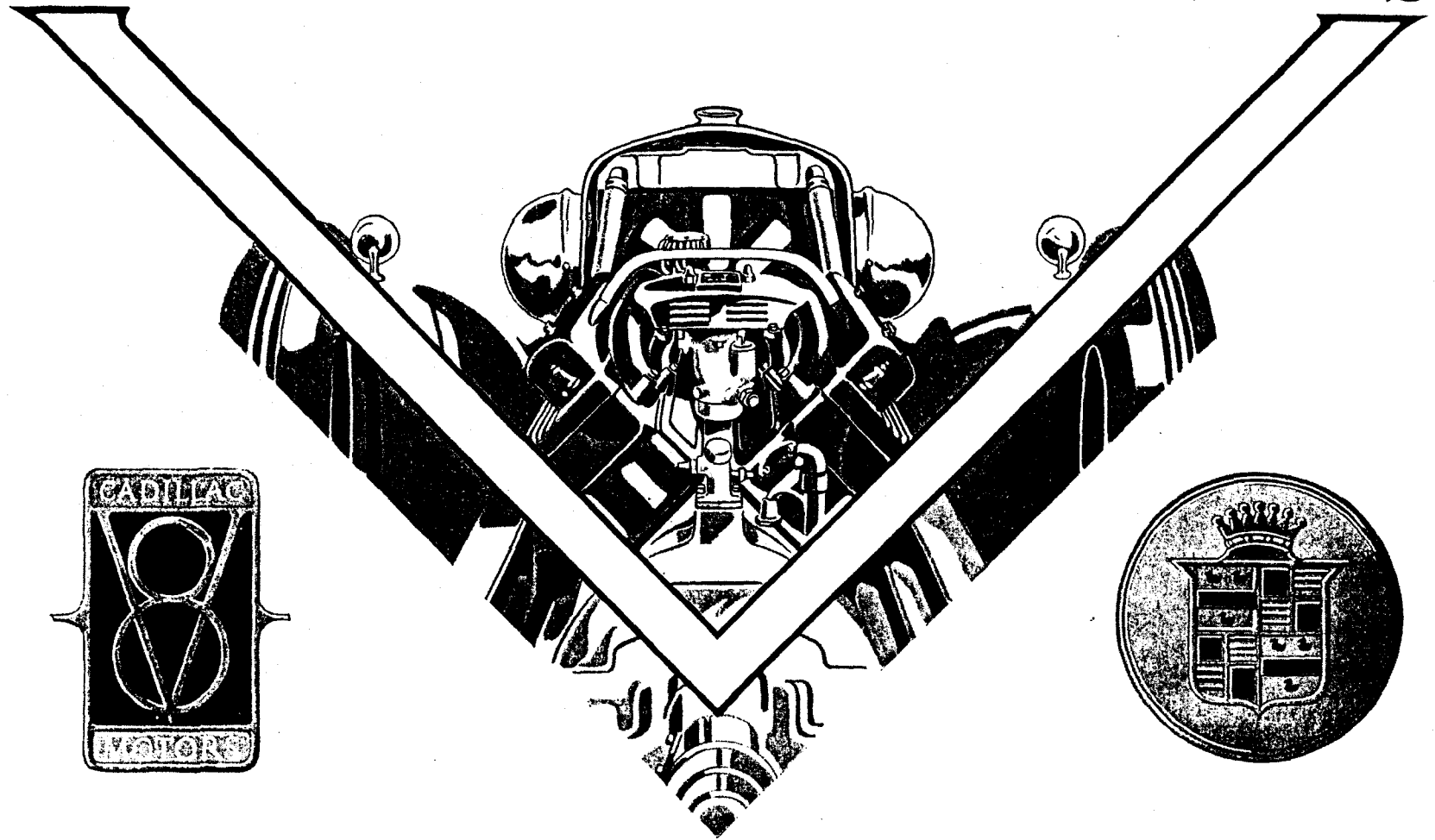

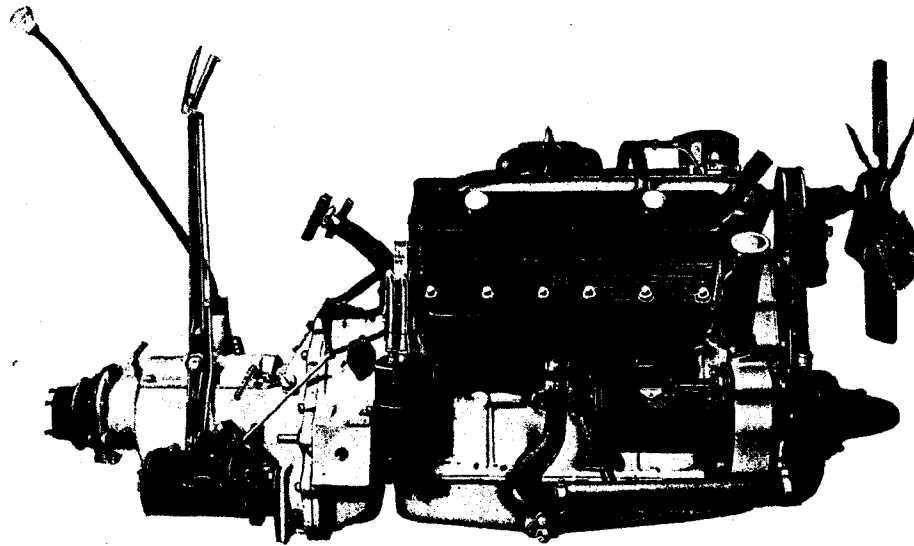

MORE THAN EVER TRIUMPHANT

Cadillac's high position in the industry is chiefly attributable to the fact that its engine is inherently superior in principle. It is the famous Cadillac V-type, eight-cylinder engine, and in the new Cadillac this great engine is capable of even finer performance, for it is enlarged, refined, and improved.

In introducing the first engine of this type, Cadillac pioneered one of the most significant developments in the whole history of automotive development.

That early engine was, in effect, two four-cylinder engines set opposite each other at an angle and built into one. It marked a complete break from the conventional practice of merely lengthening the engine to increase the capacity. It embodied a new principle. It could not have been developed by simply adding more cylinders in line any more than the steam turbine could have followed the quadruple expansion engine by merely adding another expansion stage.

Upon this engine, Cadillac based a success in fine car develop-



The bathtub. Cadillac test cars drive through water 30 inches deep at General Motors Proving Ground to insure that brakes function properly and that water will not enter the ignition and carburetor. All these tests are made so that you may obtain satisfactory performance under all conditions

V-type eight, a total of more than one and a half billion dollars—an imposing total, of which approximately one-third was attained in the past four years.

A second achievement came when Cadillac engineers developed for this engine the compensated crankshaft. This step was one of the most important developments in the history of automotive engineering. The engine was completely redesigned so that it became, in effect, four V-type engines of two cylinders each, working on a crankshaft that had been compensated so as to produce perfect balance. Vibration was further reduced. Power and smoothness were greatly increased. This change released the full potential energies of the V-type, eight-cylinder principle, and resulted in an amazing smoothness of operation.

ment that is without parallel—a success which is a brilliant triumph for its basic principle.

The motoring public has itself written the account of that success in the form of sales records. For Cadillac sales have exceeded the total volume of all other cars of the same price or higher. And the public has invested in motor cars powered with the famous Cadillac

Today, this engine continues to stand pre-eminent in the fine car field, and is the newest, most modern power plant in the industry. It possesses superior performance characteristics which no other type of engine can deliver. It is inherently balanced, inherently smooth-running, inherently efficient. And as built by Cadillac for these newest style creations, it attains utmost performance.

SEVEN SUPERIORITYES

The fundamental advantages of Cadillac engine design may be summarized by the following unquestioned facts, every one a clear-cut advantage to the Cadillac owner.

1. *The Cadillac engine is short.*

The crankshaft of an automobile engine is subjected to extreme twisting strains. These cannot be avoided; they arise inevitably from the process of translating the up-and-down motion of the pistons into the rotating motion of the shaft. Obviously, the longer the shaft, the more readily it responds to these strains; the shorter it is, the less it is affected by them.

In precisely the same way, a short crankcase has more inherent strength and stiffness than a long

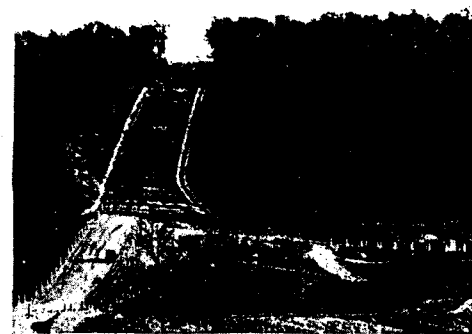

One of the many hills at the Proving Ground far steeper than any you are likely to encounter in your travels. Cadillac cars climb these hills many times before a new model is released to the public

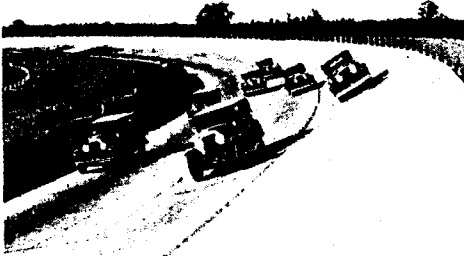

The high-speed track where durability and car performance are tested scientifically without guesswork

one, and a short camshaft is better than a long.

The Cadillac V-type eight is shorter than any other automobile engine of equal displacement, and hence less subject to these several factors of whip, vibration, and faulty alignment.

2. *The Cadillac engine is smooth running.*

A basically correct design gives the Cadillac engine a smoothness of performance that cannot be attained by other types of engines.

Because of this design, the engine functions smoothly at all speeds, is ever ready in advance for any demand, and is sensitively responsive to the touch. It is a superb power plant exquisitely refined in every phase of performance to meet the most exacting of fine car requirements.

The compensated crankshaft is one of the major contributors to the remarkable smoothness that is such an outstanding feature of the Cadillac engine. Compensating weights, permanently attached in place upon the crankshaft, cancel the last elements of centrifugal and inertia forces and eliminate vibration at its source.

3. *Cadillac design promotes carburetion and fuel distribution.*

To convey fuel from the carburetor to the combustion chamber

is a major problem in engine design. This fuel, a warm, volatile gas, is highly unstable. It must be conveyed quickly, used instantly. The basic design of the Cadillac engine simplifies this entire problem.

Cadillac design puts the carburetor in the space between the cylinder blocks, where conditions are most favorable for rapid and effective vaporization of the gasoline.

Thus, the carburetor is placed in the center with the inlet ports grouped about it. From it the fuel takes a short, direct path to its point of use, reaching the cylinders as a uniformly combustible mixture of correct proportions.

One of the chief advantages of this is that the quality of the mixture is the same in each cylinder, an extremely important factor that adds greatly to the performance of the engine.

4. *Cadillac design is simple.*

When Cadillac talks simplicity, the term is to be understood in its most fundamental, most significant sense. The V-type eight used in the Cadillac is simple because it has relatively few working parts, and because these parts are arranged for effective and continuous operation, and for easy accessibility.

With this apparatus General Motors determines the efficiency of fans and radiators. The fan draws air through a specially constructed wind tunnel into the radiator



Thus, a single carburetor with one adjustment serves every possible need. Three main bearings support the short crankshaft in precise alignment as against the seven or nine required in engines of greater length. Only four crank throws are required. A single water pump and single oil pump serve the Cadillac engine. A short, single camshaft operates the valve lifters directly, without need for intervening parts.

5. *The V-type design promotes cooling.*

Temperature within a gasoline engine should be as nearly uniform as possible, if every cylinder is to do its full, equal share of the work. Here again, the Cadillac design is a direct advantage. The entire volume of circulating water is kept within a small area, reaching easily the most remote recesses of the cylinder blocks, and traveling in direct routes back to the radiator. A single water pump

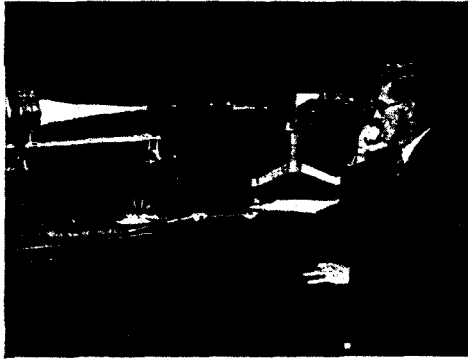

Just as raindrops separate sunlight into the colors of the rainbow, so this spectroscope at the General Motors Laboratories separates light from hot metallic vapors into its component colors, detecting minute impurities in structural materials

maintains an abundant volume of circulation.

6. *The V-type design results in most efficient lubrication.*

This advantage is again incidental to the compactness that is a salient feature of the Cadillac engine. All bearings and all operating parts are near the oil pump, and are reached by short direct leads.

It is very difficult to maintain an oil film between the crankshaft and bearing metal in a short bearing. The three large main bearings of the Cadillac V-type engine provide a wide expanse of metal from which oil does not readily drain away.

Crankcase ventilation, pioneered by Cadillac in 1925 to eliminate crank-

case oil dilution, is greatly facilitated by this principle of design. The compensators upon the rotating crankshaft build up a pressure in the crankcase and so force all vapors outward into the valve compartments. There they are used to provide efficient lubrication for the valve stems, springs, and guides.

In all these ways, the Cadillac engine design promotes long life and smooth day-by-day performance.

7. *The V-type engine provides more room for passenger space.*

An automobile power plant is but a means to an end. It exists only that you and your friends may ride with modern luxury, surety, and dispatch.

It ought, therefore, to occupy as little space as possible. In this regard, Cadillac owners are especially fortunate. Their engines, powerful and capable as they are, are short and compact. And the resulting spaciousness so noticeable in these cars is directly due to



General Motors Research Laboratories are equipped with machines to test the physical properties of steel, bronze, rubber fabric, and all the materials used in a motor car

skillful use of the space thus liberated for passenger accommodations.

Fine car owners demand tremendous power in order to obtain smoothness of operation, great acceleration, and high maximum speed. The foregoing facts illustrate why the Cadillac power plant is best fitted to these requirements. Its capacity is not limited by factors of its own design, but can be increased as needed without sacrifice of smoothness or efficiency. Compact and simple, perfectly cooled, thoroughly lubricated, efficient in carburetion and in fuel distribution, the Cadillac V-type, eight-cylinder engine will meet with distinction any test you care to impose upon it.

CRANKCASE

The crankcase forms a base for the entire power plant. It supports the crankshaft, cylinder blocks, and other essential parts of the engine. To do this, it must provide strength and rigidity with a minimum amount of weight. The most striking characteristic of the Cadillac crankcase is its weight efficiency, with but a fraction of the



size and weight which might be expected of an engine with the power of the Cadillac. The material employed is a silicon-

The X-ray provides another tool for the research engineer in his quest for more information on the internal structure of materials likely to be used in Cadillac automobiles

aluminum alloy specially treated with a strength-to-weight ratio more than twice that of an iron casting. A great deal of effort has been expended in developing a case which is non-resonant. This, coupled with extreme rigidity in both the horizontal and vertical planes, gives freedom from rumbles and vibrations. The walls of the case are adequately reinforced by ribbing, and support the crankshaft and camshaft bearings.

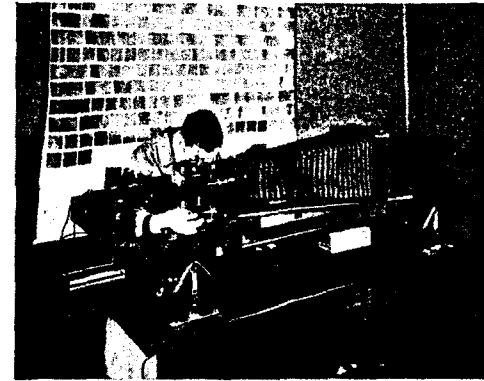

Photographing the structure of a piece of metal at the General Motors Research Laboratories under a microscope. This photomicroscope allows metallurgists to see what the metal looks like when magnified 6000 times

BEARINGS

The crankshaft is supported on three main bearings which provide ample bearing area. Since the Cadillac crankshaft has been completely compensated, the bearings are relieved of all loads other than those due to the weight of the parts and the power impulses. The bearings are babbitt lined and are assembled to the case in such a manner as to secure proper clearance and perfect alignment.

CRANKSHAFT

The crankshaft has the important function of converting the reciprocating motion of the connecting rods into the smooth, even

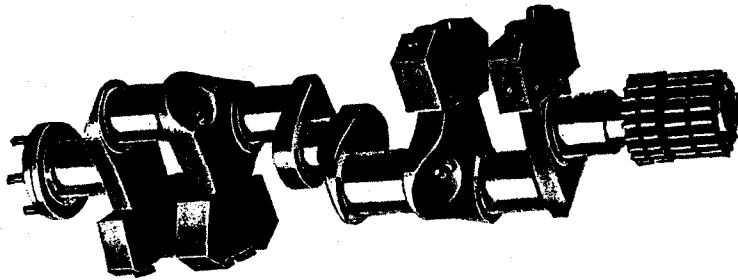

The backbone of the Cadillac power plant; the two-plane compensated crankshaft inherently balanced and built to withstand all manner of torsional stresses.

rotation of the flywheel and power transmission system. The combined torsion and bending stresses imposed upon any shafting which transmits power must be met by considering in their proper relationship three sets of factors—the unsupported length, the dimensions of the shaft, and the material used in its construction. The salient points of the Cadillac engine become especially apparent when the crankshaft is examined for these three factors.

The Cadillac crankshaft has the shortest overall length of any engine of equal displacement. The length of the shaft between the outer ends of the forward and rear main bearings is $23\frac{3}{4}$ inches, of which $6\frac{1}{2}$ inches comprise the three main bearings, while the diameter of the shaft is $2\frac{3}{8}$ inches. This short overall length and large diameter eliminate torsional forces and crankshaft whip. The shaft is forged from a carbon steel of a high tensile and shearing strength, with the throws lying in two planes and provided with compensators so that inherent balance is secured. After manufacture each crankshaft is balanced on a balancing machine, developed

by the General Motors Research Laboratories, to insure that no vibration may mar the smooth performance of the Cadillac engine.

PISTONS

A piston has to withstand the direct impact of the explosion and transmit this force through the connecting rods down to the crankshaft. It is essential that the weight of the pistons be reduced to a minimum and still provide ample strength without distortion when subjected to the high temperature within the walls of the combustion chamber.

Nickel cast iron has proved to be the best material for the manufacture of pistons. Since the cylinder blocks are made of a similar material, unequal expansion is completely eliminated. The Cadillac piston design uses this material to the best advantage, giving great strength and rigidity with a minimum of weight. Because of the compensated crankshaft, the effects of piston weight have been greatly minimized and are completely balanced by the crankshaft. The pistons are fitted with four rings, three of which are mounted above the wrist pin and one below. The lowest ring is of the slotted type in a drilled ring groove, enabling ex-



Testing cars in the cold of the arctic. In this General Motors cold room, engineers study the operation of cars and parts at temperatures as low as 50 degrees below zero

cess oil to drain back through the piston into the crankcase. The wrist pin which connects the piston to the connecting rod is locked to one end of the piston by a set screw. It is free to move in the other end, thus providing for all expansion which may occur without distorting the piston.

CONNECTING RODS

The connecting rods, which transfer a maximum thrust of approximately one and one-half tons per explosion from the piston to the crankshaft, have been given attention in design and manufacture commensurate with the importance of their function. The connecting rods from opposite blocks are set side by side on the same crank throw. The rods are drop-forged from a special formula steel to an I section with the web of the I in the plane of lateral motion. Where stress can be depended upon to remain in one

plane, this shape is the lightest and strongest available.

The rods are rifle-bored to provide forced lubrication for the piston pin. An unusual feature is the diamond boring of the bearings in both ends of the rod, insuring a perfect fit and consequent

Workmen wear special clothes to completely protect them from the fine stream of sand which is blown under terrific pressure against each Cadillac crankcase, removing all scale and dirt before inspection and machining



long life with quiet operation.

CYLINDER BLOCKS

The Cadillac cylinders are cast four en bloc, with detachable heads.

Cylinders are set slightly staggered to permit use of

side-by-side connecting rods with both inlet and exhaust valves on the same side of the combustion chamber. The cylinder block material is a nickel cast iron of similar composition to that used for the pistons, giving exceptional wearing qualities and facilitating the formation of a "glass-like" surface produced by honing the walls of the bore. This alloy is considerably more expensive than gray iron usually used for cylinders and pistons. The expense is justified, however, in view of the perfect finish obtained by the honing process, which permits every Cadillac owner to obtain maximum performance upon delivery. An ornamental cover conceals the top of the cylinder head and spark plugs, eliminating short circuits which might be caused by moisture and oil collecting on the terminals and wires.

VALVE MECHANISM

The valve mechanism of the Cadillac engine is extremely simple and all unnecessary parts, such as rocker arms, are eliminated. The camshaft is a drop-forging supported on four bearings with sixteen integral cams, each operating one of the sixteen valves. The camshaft is drilled throughout its entire length to eliminate

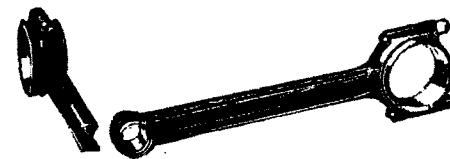

Piston pin lubrication is assured by rifle boring the connecting rods throughout their length. This permits oil under pressure to reach this point, assuring long life.

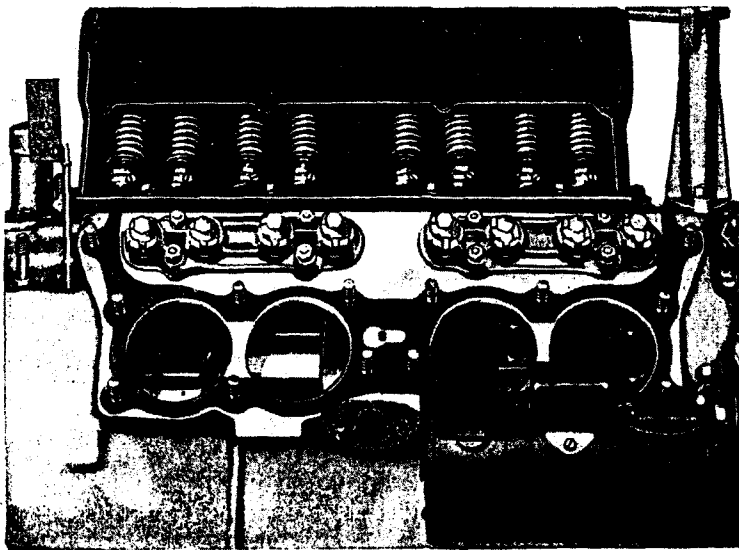

Cadillac valves are operated through cam slides placed in groups of fours. Adjustment when required is easily effected with only a screw driver and a single wrench. This cam slide construction eliminates the necessity of holding the tappet in position while the adjustment is being made.

excess weight and to provide a passage for oil which is supplied to each of the bearings under pressure. Each valve is actuated by a cam slide carrying a hardened steel roller which rides upon the cam. The cam slides operate in bushings assembled to the crankcase in groups of four. These bushings are very accurately machined and aligned, with dimensions whose limits vary no more than .0005 of an inch. The cam slides are maintained in a fixed position which simplifies adjustment since only a screw driver and a single wrench are necessary for this operation. The Cadillac valves are forged

from a high quality steel; inlet valves being of tungsten steel and exhaust valves of silico-chrome. The clear diameter of the intake valve is $1\frac{5}{8}$ inches, while that of the exhaust is $1\frac{9}{16}$ inches. The valve stems have their bearings in guides pressed into the cylinder blocks. The valve lift is $\frac{2\frac{3}{4}}{64}$ inch. Intake valve seats are at an angle of 30 degrees, in order to give freer passage to the gases when the valves are opened. The exhaust valves are at an angle of 45 degrees, in order to compensate for the difference in expansion between the cylinder blocks and valve stem. The combustion chamber is designed so as to eliminate all masking of the valves, greatly improving volumetric efficiency.

CHAIN MECHANISM

The camshaft is driven from the crankshaft by a silent chain. A chain drive has several advantages over gears in that it provides a flexible connection between these two shafts, giving opportunity to absorb minor vibrations caused by the valve springs. A chain is also quieter than a gear and, when properly lubricated, will retain its quietness throughout its life. A second silent chain is used to drive the water pump and generator.



Aluminum for crankcases, carburetors, and other parts is melted in these oil-fired furnaces which are maintained at the proper temperature

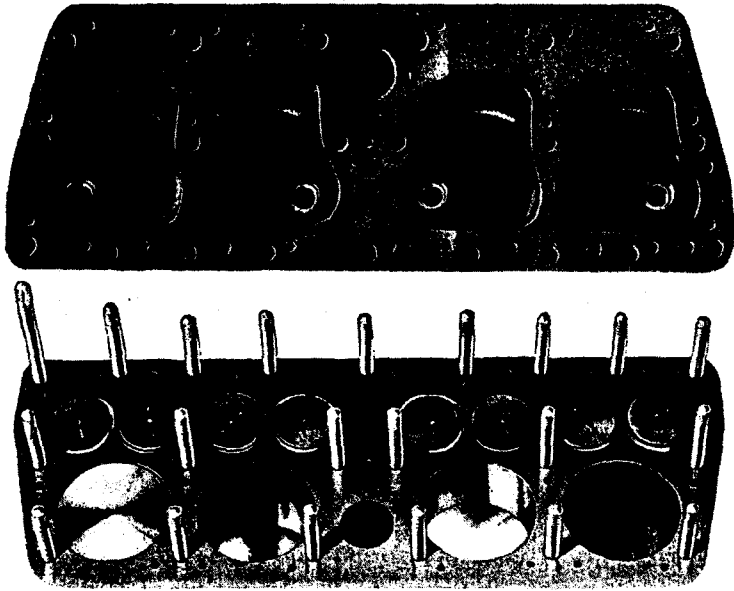

The combustion chamber has been designed to eliminate all masking of the valves, permitting easy entrance and exit for the hot gases and insuring higher volumetric efficiency.

EXHAUST MANIFOLD

Exhaust gases from the two cylinder blocks are led from individual manifolds to the front of the engine, where they enter a common manifold connected to a pipe passing between the engine and the frame. These manifolds are finished with a porcelain enamel baked in special ovens so that their appearance will not be marred by the intense heat to which they are subjected. A tail pipe on the left side of the car carries the exhaust gases from the muffler to the extreme rear of the chassis, making for unusually quiet operation.

The discharge of exhaust gases at the extreme left rear is advantageous also when occupants alight or enter from the right side.

FUEL SYSTEM

Gasoline is carried in a 25-gallon tank at the rear of the frame, provided with a large filler opening projecting outside of the frame member through a valance. Filling is facilitated by a vent pipe incorporated into the filler, permitting the escape of air and preventing splashing while the tank is being filled.

VACUUM PUMP

The fuel is delivered to the carburetor from a vacuum tank mounted on the dash. The system differs, however, from the usual vacuum system in that the fuel feed is positive, regardless of engine speed or throttle position. This is assured by a special vacuum pump mounted at the rear of the crankcase which is driven by an eccentric on the camshaft. The pump assists the intake manifold vacuum at all times. This feature will be especially appreciated in climbing long hills or running at top speed for great distances. This arrangement is entirely unique and is protected by Cadillac patents. The engine fuel



Pouring aluminum. The white-hot silvery metal is poured into sand moulds to form Cadillac parts

is cleaned twice in its passage between the gasoline tank and the carburetor by two straining devices, once before entering the vacuum tank and again after leaving it. The second fuel strainer is of a visible type which may be readily opened for cleansing, and eliminates all water as well as solid particles.

CARBURETOR

Cadillac engineers have designed the carburetor as an integral part of the power plant and have not, as in many cases, considered it as an accessory. It is designed to meet every requirement of the Cadillac V-type, eight-cylinder engine. It is of the air valve single jet type, but with a number of exclusive features. The fuel level is maintained by a cork float hinged at one side of the bowl and encircling the spray nozzle. This design has a marked advantage

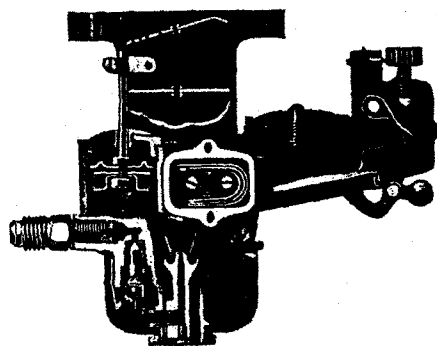

The Cadillac carburetor, with automatic throttle, concentric float chamber, and thermostatic control, successfully meets every requirement of perfect carburetion for the Cadillac V-type engine.

in that change in the fuel level, brought about through changes of car position when ascending and descending grades, is greatly minimized. This insures a more uniform mixture and renders the carburetor less subject to the motion of the car.

The carburetor is provided with three thermostats which render seasonal adjustment of the

The crankcase surfaces upon which the cylinder blocks are fastened must be absolutely true. This giant milling machine squares the surfaces to form a perfect seat for the cylinder blocks

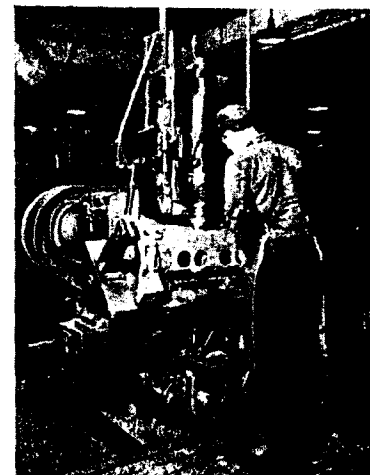

carburetor unnecessary. The auxiliary air supply by which the correct mixture is automatically maintained at all speeds and throttle openings is controlled by a leather-seated swing valve governed by an adjustable spring. One of the three thermostats controls the action of this valve. A

richer mixture, for accelerating, is provided by a throttle pump at one side of the carburetor. It is a simple plunger pump operated directly from the throttle shaft, furnishing extra fuel in the spray nozzle when the accelerator is depressed rapidly. The second thermostat regulates the action of this pump to compensate for changes in temperature. The third thermostat, acting at unusually high temperature, opens a vent to permit the escape of gas pressure from the float bowl which might be generated in very hot weather with "high test" gasoline. An automatic throttle is provided to prevent surging and fluttering of the air valve when accelerating.

EXHAUST-HEATED INTAKE HEADER

The carburetor is located between the cylinder blocks connected to the two short intake manifolds by an exhaust-heated intake header. The intake header is provided with passages con-

necting with each of the two exhaust manifolds. An automatically operated butterfly valve is located at the forward end of the left exhaust manifold to control the temperature in the header. When this valve is closed, the exhaust gases from the left cylinders must pass through the intake header jacket to the right exhaust manifold, thus giving the maximum amount of heat for complete car-

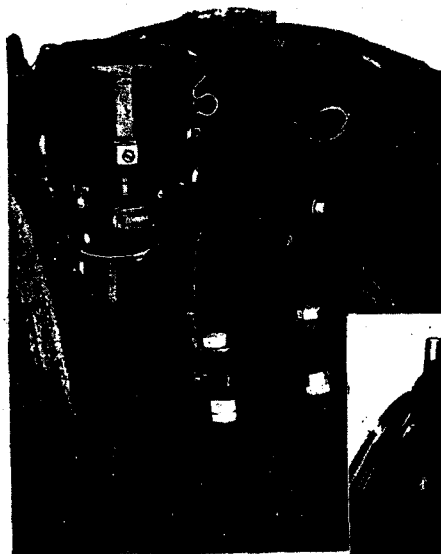

Easy starting and satisfactory operation during cold weather are assured by this automatic heat control valve, providing the maximum heat for starting without resulting losses of power at high temperatures and speeds from overheating.

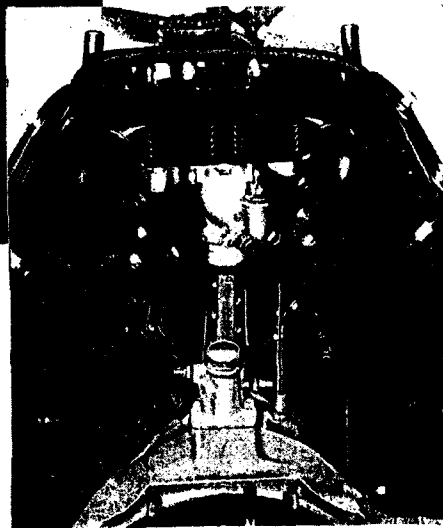

The Cadillac fuel system includes a vacuum pump so that an adequate supply of fuel may be obtained at all times. The position of the carburetor permits the use of short manifolds and direct passages.

This giant multiple spindle drill drills all the holes in the under side of the crankcase in one operation, insuring the correct location for all holes and perfect alignment of the crankcase

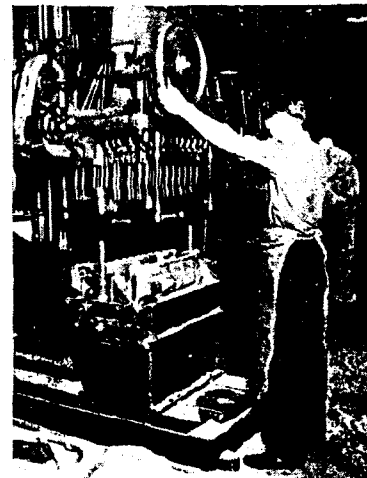

buration. When the engine is operating, this valve may be partially open and the amount of heat is then just enough to maintain carburetion without power loss from overheating. This valve has only one moving part which is operated by gravity and the pressure in the exhaust system. The intake manifolds are of the high turbulence type, insuring perfect distribution under all conditions. A sheet metal cover is provided on top of the header which greatly improves the appearance, as it blends into the covers on the cylinder blocks, giving a finished touch to the whole power plant.

ELECTRICAL SYSTEM

Many years ago, Cadillac engineers realized the importance of a completely satisfactory electrical system. In 1912, this system was so designed that it eliminated for the first time the necessity of hand cranking. The present Cadillac employs a Delco-Remy system embodying many features found in the first complete electrical system introduced to the industry by Cadillac.

The current source is an Exide 6-volt storage battery with a 130-ampere hour capacity. This battery was especially designed

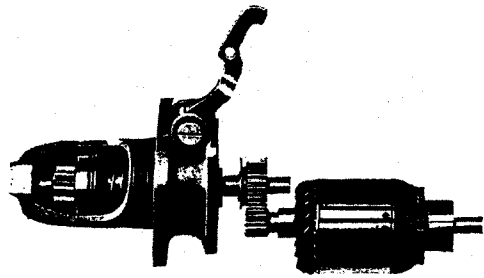

Unusual care has been taken to provide easy starting without excessive drain on the battery, thus assuring its long life.

for the Cadillac car and will give uninterrupted service and long life. It is carried in a dust shield compartment on the right side, accessible by removing a cover. The battery is charged by a generator driven from the crankshaft through a silent chain at $1\frac{1}{6}$ times engine speed. The generator is located directly back of the water pump on the right side of the engine. Current regulation is afforded by an adjustable third brush and an automatic thermostatic switch.

This switch permits high charging rates during cold weather and on short trips where frequent use is made of the starter with a great drain on the battery. On long trips in warm weather, this switch reduces the charging rate, preventing overcharging of the battery and eliminating the necessity for burning headlights while touring. An automatic cut-out is provided on the generator to disconnect it from the storage battery when the engine is not operating or when its speed is such that the generator voltage is below that of the storage battery.

The starting motor is of the 4-pole type and drives the flywheel through a double reduction gearing. This provides an overall reduction of 25 to 1, greatly reducing the load on the storage battery during extremely cold weather. A positive engagement for the

starter pinion is provided, controlled by the starter pedal. The gears are thus relieved of all shock loads, giving longer life and quieter operation.

The entire electrical system is of a single wire type, the circuit being completed through the frame. All connections between the chassis and body circuits are made through accessible terminal blocks on the dash. The system is protected against short circuits by automatic circuit breakers. Two breakers are provided; one, known as the lockout breaker, the other as a vibrating breaker. When short circuits occur on headlamps or other units, readily accessible, the vibrating breaker opens and closes, making a vibrating noise indicating a short circuit which will continue until the trouble has been corrected.

Other units, such as the horn, where a continued vibration is undesirable, are connected through the lockout breaker which opens and remains open until the disturbance is removed. This completely eliminates fuses found in other designs, and no owner will ever be delayed for lack of fuses.

When short circuits are corrected, the current will automatically be returned.



All bronze bushings and brass parts are cast in Cadillac foundries. The metal is melted in rocking electric furnaces, then poured into ladles from which it is repoured into sand moulds



Exhaust manifolds must resist high temperature and great care has been taken to provide a finish which will not crack and rust in use. Manifolds are sand-blasted to remove all dirt before being dipped in the porcelain enamel

LIGHTING

Two large headlamps, 13 inches in diameter, of the bullet type are provided. These lamps have a windsplit, tapering from the front to the apex at the rear, and this design is duplicated in the two parking lamps carried on the front fenders. The headlamps have double filament bulbs giving two beam positions, one for driving on the open road and a depressed beam for use when passing vehicles approaching from the opposite direction. Highly efficient fluted diffusing lenses spread out and deflect the rays, giving ample illumination without excessive glare to others on the highway.

The lamps are controlled by a switch located at the base of the steering column, operated by a single lever in the center of the steering wheel. The instrument board lamps are controlled by a separate switch on the instrument board.

Two tail lights are provided, one on each rear fender. These lamps contain two bulbs, one a 3-candle power bulb for the tail light and the other a 15-candle power bulb which acts as a stop signal when the brake pedal is depressed. A high-frequency vibrator type horn of exceptional tone is located at the left side of the radiator, attached to the headlamp support.

IGNITION SYSTEM

The gasoline engine obtains its power by burning an explosive mixture of gasoline and air. This mixture is fired by an electric spark which, in the Cadillac, is produced by a Delco-Remy ignition system of the high tension type—a simple reliable design which has proved its merit since the first eight-cylinder V-type engine.

The ignition system consists of an ignition timer which interrupts the low tension current, producing a high voltage in the secondary circuit of the induction coil. A distributor is provided to

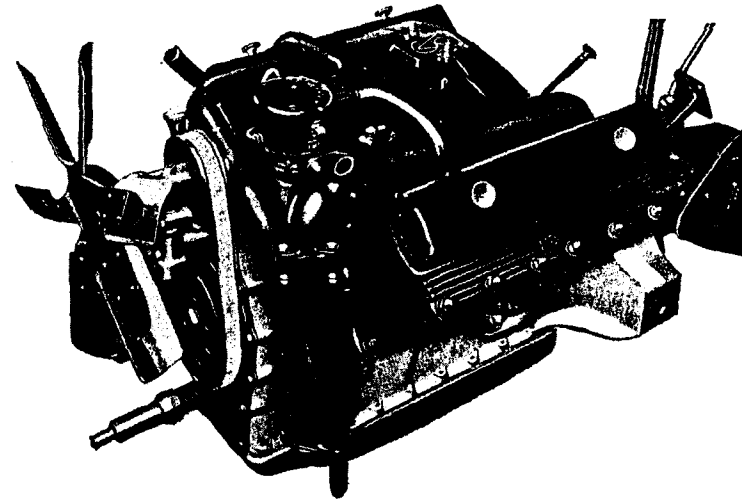

The ignition system includes a new and distinctive distributor, greatly improving the appearance of the engine and protecting the wires from moisture and dirt. Spark plug covers and an attractive metal conduit carry out this treatment to its logical and complete conclusion.

distribute the high tension current produced by the coil to the proper cylinder. The induction coil is of the iron-clad type and is completely enclosed with a waterproof Bakelite cap. A condenser is mounted in the breaker housing which protects the contact points against burning and assists the coil in building up a high secondary voltage.

The timer, distributor, and condenser are assembled into a single unit which is mounted at the front of the crankcase. The distributor cover is of a new and improved design, and completely protects the terminals from moisture and dirt. A conduit meets this distributor and extends across the V into the spark plug covers, leading the high tension wires to the different spark plugs.

The Cadillac ignition system embodies several unusual features which have contributed to the remarkable performance of this



The cylinders are poured from this giant ladle, moving about the foundry on an overhead track. This insures that the white-hot nickel iron will reach the moulds soon after it leaves the cupola so that its temperature may be high, insuring satisfactory castings

power plant. The timer, which is driven by a vertical shaft and spiral gears from the camshaft, is equipped with a 4-lobed cam operating two sets of contact points. These break alternately, sharing the work which would otherwise be done by one. An automatic governor is provided to advance the spark. This feature has been on Cadillac cars

Cylinder blocks mounted on this giant drum pass between milling cutters which square the surfaces to which the inlet and exhaust manifolds are bolted



since 1906. The automatic spark control is so effective that it has been possible to remove the control lever from the steering column and place it on the instrument board. The firing order of the cylinders is as follows:

Front	8	7	5	2
	1	4	6	3

The ignition system is controlled by a simple coincidental lock on the instrument panel which opens the ignition circuit and locks the transmission in the neutral or reverse position simultaneously. This lock is fool-proof and affords double protection, since it locks both ignition and transmission. It is possible with this lock to put the car in reverse and lock it in that position when parking on steep gradients, as an added safety feature.

COOLING SYSTEM

The cooling system of the Cadillac is one of the simplest and most effective to be found in the entire industry. Cadillac engineers were the first to realize the necessity for complete regulation of the cooling medium providing thermostatic control. This has been retained in the system and adapted to the needs of the new and larger Cadillac of today.

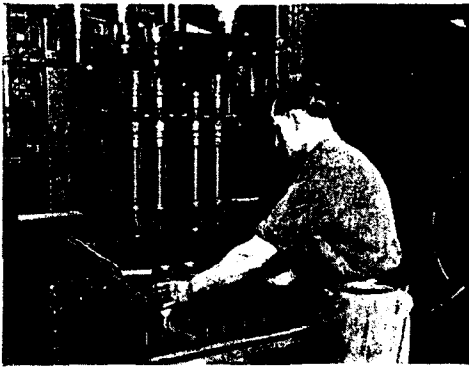

Cadillac cylinders are finished by a honing process giving a smooth, glass-like finish to this important unit.

The circulation of water through the radiator and cylinder jackets is effected by a centrifugal pump, mounted on the right side of the engine driven by a silent chain from the crankshaft. The pump is coupled to the driven sprocket by a flexible coupling of laminated spring steel, permitting the pump shaft to align itself, protecting the packing from wear. The radiator is of the cellular type, giving a large area for the dissipation of heat to maintain the temperature at the most effective point. It is fitted with vertical balanced shutters controlled by a thermostat mounted on the upper radiator tank. When the engine is cold, the shutters are automatically closed, preventing the passage of air through the radiator. When the temperature of the water reaches a predetermined point, the thermostat opens the shutters to such an extent as to maintain the most desirable temperature for efficient engine operation. The shutters not only control the temperature of the water, but also the temperature of the air under the hood, thereby assisting carburetion, and in conjunction with the thermostatically controlled carburetor reducing the "warming-up" period.

A temperature indicator is provided on the instrument board to indicate the exact temperature of the motor at all times. Air circula-

tion through the radiator is provided by a 6-blade fan driven by a V-belt from the crankshaft. This fan is mounted in Durex bushings automatically lubricated by a lead from the oil pressure regulator. The oil is drained from the fan bearings through the mounting bracket back to the crankcase where it is returned to the circulatory system.

LUBRICATION SYSTEM

Lubrication, which is one of the most essential elements to continued satisfactory operation, is provided in the Cadillac power plant by a full pressure system. Pressure is furnished by a gear pump driven from an extension of the distributor shaft. This pump is attached to a cap on the front main bearing which it supplies through a direct passage. The oil supply is maintained in a pressed steel reservoir of 8 quarts capacity which closes the under side of the crankcase. The entire area of the reservoir is covered by a fine mesh screen, giving abundant area for

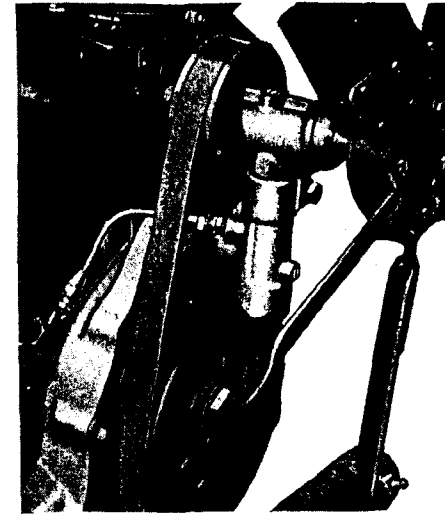

Durex bushings supporting the fan receive direct pressure lubrication from the engine lubricating system, assuring long life for this important unit.

straining. All the oil drained back from the bearings, cylinder walls, and other parts must pass through this screen before it can reach the inlet to the pump for a second passage through the system.

As an added protection for the finely machined engine surfaces, an external oil filter is provided at the right side of the crankcase to remove all grit and abrasives from the engine oil. Oil passes through this filter under pressure and solid particles are completely removed.

Oil is forced by the pump to a manifold fitting running the entire length of the crankcase. Leads connect this manifold to the center and rear main bearings, the rear camshaft bearing, the pressure gauge, and the oil filter. The crankshaft is provided with oil passages connecting the journals of the main and the connecting rod bearings. Oil from the main bearings is delivered to each of the connecting rod bearings and from there supplied under pressure to the wrist pins through passages in the connecting rods.

Oil forced from the connecting rod bearings is thrown by centrifugal force on to the cylinder walls and pistons, lubricating them. The camshaft receives oil through its rear main bearing, from which it is led through the hollow shaft and thrown by centrifugal force on the bearing surfaces of the other three bearings. The pressure throughout the circulatory system is controlled by a piston valve pressure regulator mounted on the crankcase in front of the right cylinder block. Overflow from this valve lubricates the chain and chain mechanism, and a lead is also provided for pressure lubrication of the fan bearing.

The valve stems are automatically lubricated through ports in the cylinder walls which emit a fine mist of oil vapor from the crankcase ventilating system. This mist provides excellent lubrication for valve springs, stems, and guides. Oil level is indicated by a gauge at the rear of the right cylinder block on top of the crankcase. This gauge is operated by a float in the oil pan. Oil pressure in the system is shown on a gauge mounted on the instrument panel.

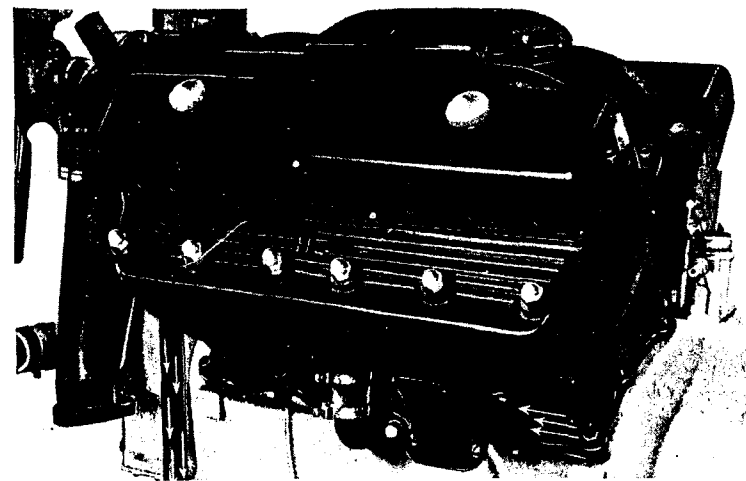

Air is drawn into the crankcase on the right side, as shown by the arrows, building up a pressure within the case, providing an effective crankcase ventilation. Vapors are expelled into the pipe at the left removing all condensation products.

tion for valve springs, stems, and guides. Oil level is indicated by a gauge at the rear of the right cylinder block on top of the crankcase. This gauge is operated by a float in the oil pan. Oil pressure in the system is shown on a gauge mounted on the instrument panel.

CRANKCASE VENTILATION

One of the most significant developments pioneered by Cadillac is the crankcase ventilating system, which was introduced in 1925 to eliminate the evils brought about through the contamination of the crankcase oil by water and unburned fuel vapors. Because of this

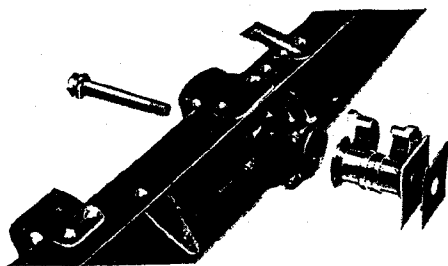

Specially designed rubber mountings support the Cadillac engine at the rear of the crankcase. They completely insulate the engine so that noise is not transmitted to the interior of the car.

development, oil changes are necessary only after 2000 miles of operation as contrasted to the frequent changes at 500-mile intervals required before the introduction of this feature. The system is extremely simple and contains no moving parts to require attention or care. An air port is provided in the left side of the crankcase. The crankshaft with its compensators acts as an air pump, drawing preheated air through this port, building up a pressure within the crankcase slightly greater than atmospheric. A port is provided in each cylinder wall which is uncovered on the upward stroke of the piston. During the down stroke, seepage vapors passing the piston rings are held by this crankcase pressure, and forced through these ports on the return stroke into the valve compartment where they provide lubrication for the valve mechanism. Conduits conduct this mist from the valve compartment to the under side of the car where it may drain away.

ENGINE SUSPENSION

The power plant is mounted in the frame by a 3-point suspension. This mounting is desirable in that it minimizes strains in the crankcase and prevents distortion of bearings and other parts when driving over rough roads. The mounting consists of a ball-

and-socket joint at the forward end and two specially designed rubber-lined mountings at the rear of the crankcase. These rubber mountings assist in preventing body rumbles by acting as a complete insulation for the engine, so that any engine noise which might possibly develop cannot be transmitted to the interior of the car. The rubber employed for this mounting has great durability and forms a permanent cushion.

CLUTCH

The clutch of an automobile is called upon to perform a very severe duty. It must absorb the shock incident to connecting the rotating shaft of the engine to the stationary vehicle. It must also require a minimum of effort for disengagement, and to permit proper gear shifting must cease spinning promptly when disengaged. The Cadillac clutch completely meets all of these requirements. It is of the dry plate type with two driven discs each 10 inches in outside diameter, faced on both sides with compressed fabric. All springs, levers, and other parts are attached to the flywheel, greatly reducing the moment of inertia, and consequently eliminating all tendency for spinning. The clutch throwout bearing moves on a sleeve mounted on the transmis-

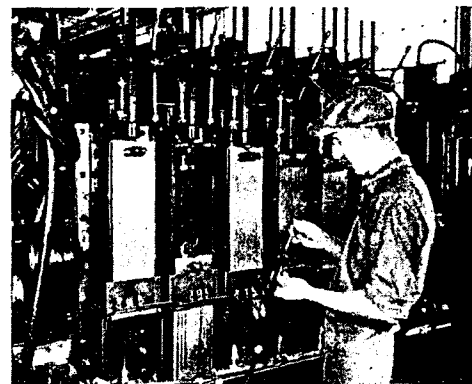

Connecting rods are rifle-bored on this machine to provide lubrication for piston pins

sion case and has no tendency to spin. This design of clutch will withstand, without need of frequent adjustment, all manner of stress to which it is likely to be subjected.

The perfect inherent balance of the engine would be quite useless if the other parts rotating with it were not balanced to the same degree. The Cadillac clutch is completely balanced before being assembled to the flywheel, so that it will preserve the smooth performance afforded by the famous Cadillac compensated crankshaft.

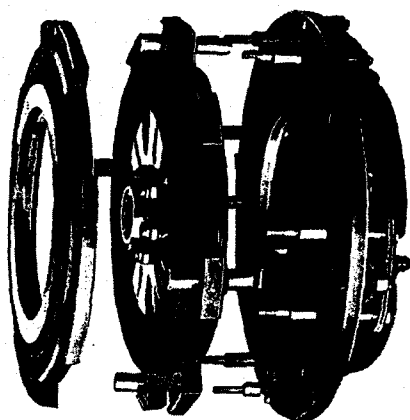

The Cadillac clutch provides positive engagement with extremely light pedal pressures. This clutch is of a two-plate design, and provision has been made for a positive release of the driven plates when the clutch is disengaged.

The inertia of this clutch is remarkably low, insuring easy gear shifting, thus assisting Syncro-Mesh transmission in obtaining perfect synchronization.

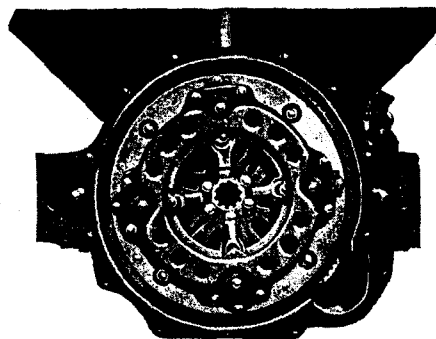

Syncro-Mesh transmission

In 1928, Cadillac engineers announced a new development in transmission design which enables gears to be shifted forward and backward without clashing. With this transmission, a novice can shift as noiselessly as an expert.

The principle of this transmission is simple and positive. It provides three speeds forward and one reverse as in conventional practice. It differs, however, in

that all gears except low and reverse are in constant mesh. A coupling, fitted with friction cones, is provided to connect the drive shaft with either the second-speed or high-speed gears by means of internal teeth. In shifting, the conical member engages a corresponding member on the second or high-speed gear before the teeth on the gear and

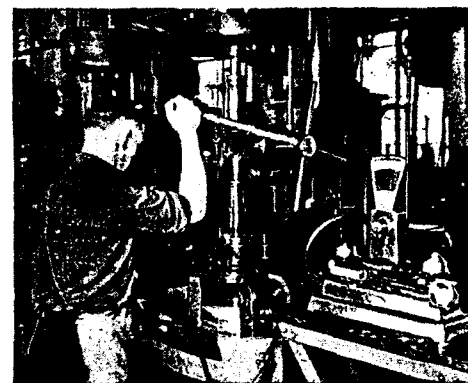

Smooth performance and perfect balance of the Cadillac engine are secured by accurately weighing each end of the connecting rod and then machining to bring the weight within specified limits

the coupling meet, causing the rotating parts to travel at the same speed, enabling complete engagement to be effected readily. The motion of the coupling and its cones is controlled by a special cam and two hydraulic controls to provide perfect tooth engagement at all times. The positions of the control lever in the various gear

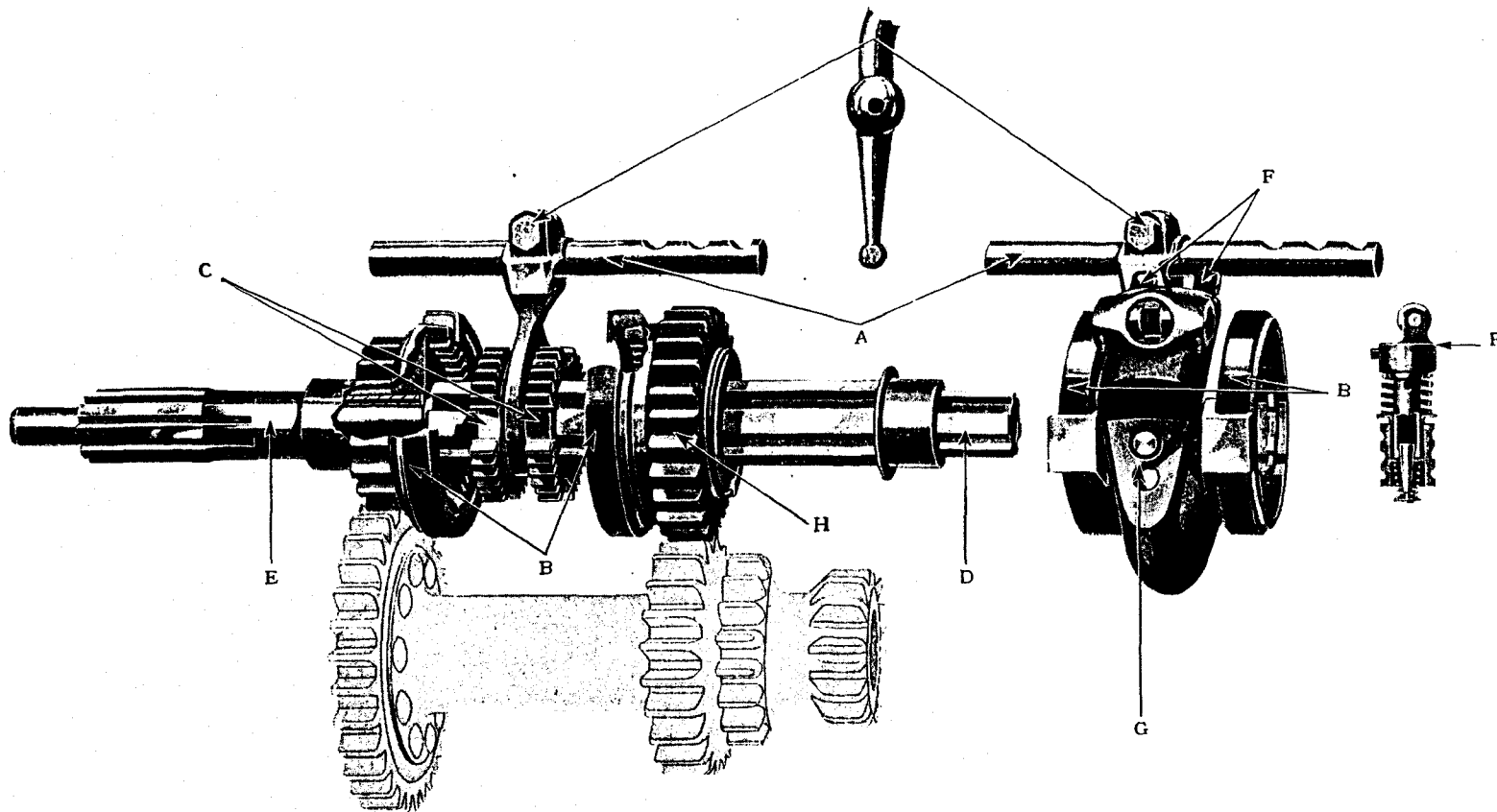

THE SYNCRO-MESH TRANSMISSION

Shaft E is connected to the clutch and rotates with it at all times. Shaft D is connected by the propeller shaft to the rear wheels. To transmit power these shafts must be locked together either directly or through a gear train. Shaft E provides a bearing for the main shaft D, which is free to rotate within it. Shaft E also drives a countershaft which in turn drives a constant mesh gear H, free to rotate on shaft D. To engage high or second speeds the gear shift lever is operated in the usual manner. It moves the shifting fork A which in turn controls the coupling C. This coupling is splined to the main shaft D and engages either the gear on shaft E or the gear H by means of internal teeth. When this coupling is

moved to the left, high speed is obtained since shafts D and E are locked together without any intervening gears. When the coupling is moved to the right, shaft D is locked to the gear H which provides a gear reduction through the countershaft. Synchronization is effected by cone clutches B which are supported by the yoke G. This yoke surrounds the coupling C and is actuated by a machined surface on the shifting fork A. Two hydraulic dash pots F time the synchronization period so that the cone clutches B will make contact before coupling C meshes into the gears, and springs in the yoke G insure the cones separating after engagement has been effected to insure long life and satisfactory operation.



Pistons are gauged for eccentricity on this sensitive machine and then assorted into groups varying from each other by only a thousandth of an inch, so that they may be matched with cylinders of like dimensions

combinations remain unchanged and the method of operation is as heretofore. It is no longer necessary to hesitate momentarily in neutral but the lever may be moved with an even and uniform motion. The gears and shafts of the Cadillac transmission are of alloy steel, casehardened. The faces of the teeth are cut on a gear shaper and then accurately ground to a perfect involute. The tooth faces have been widened to distribute the pressure on a larger area, resulting in a reduction of wear and gear noise.

This transmission has been designed so as to enable Cadillac cars to meet the traffic conditions of today. A few years ago, when there were far fewer automobiles on the street, the problem of get-away in traffic did not exist. Today, however, is a different story; the motorist who wants to save time in crowded city streets must be able to slide out ahead of the procession when the traffic signal flashes green. The Syncro-Mesh transmission enables him to do so. It permits him to make a quick, silent shift without the slightest bit of effort. No time is lost in neutral; all that needs be done is to disengage the clutch, slide the gear lever into position—and go.

When descending long, steep hills or mountain gradients in a

car fitted with a conventional type transmission, it is not possible to shift into second without practically bringing the car to a standstill. Even then, there is some clashing of the gears.

With the Cadillac Syncro-Mesh transmission, while descending a grade in high gear, it is possible without slowing down the car to engage second gear noiselessly, simply, easily, and without damage to the gear set. This feature will be appreciated by everyone when driving through rolling country, assuring as it does complete control over the car on hills and the mental ease which such certainty of control affords.

PROPELLER SHAFT

The propeller shaft transmits the torque of the engine to the rear axles and is subjected to tremendous torsional stresses. It has a tubular section, 2½ inches in diameter, which section pro-

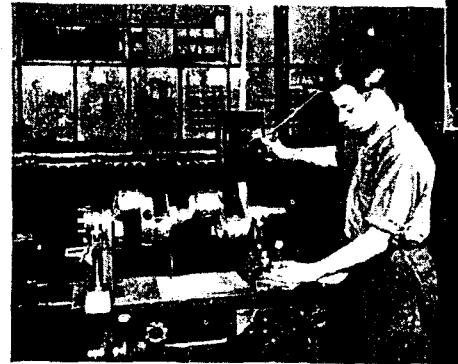
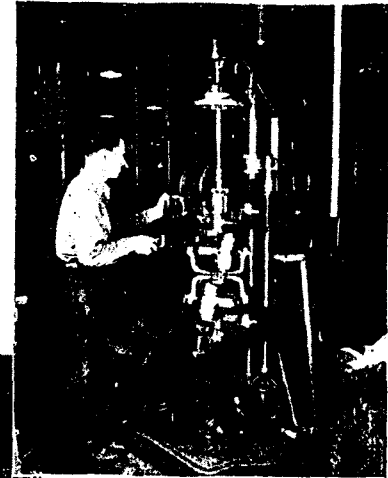

The compensated crankshaft is balanced on these special machines to completely eliminate all vibration, thus providing exceptionally smooth performance



The carburetor is built entirely in the Cadillac plant and assembled by hand so that these small parts may be accurately fitted for perfect carburetion

vides the greatest torsional strength for a given weight of metal. The shaft rotates within a torque tube, completely enclosing the entire assembly. The rear of this shaft is rigidly connected to the pinion shaft by a splined sleeve, while its forward end is connected to the transmission shaft by a universal joint immedi-

ately behind the transmission case and lubricated directly from the transmission. The torque tube absorbs all driving and braking forces, relieving the springs of all duties other than supporting the chassis and body. Torsional stresses are carried through this tube to a large ball-and-socket joint at the rear of the transmission case where they are absorbed and carried into the frame. This design gives the chassis engineer opportunity to design springs for maximum riding comfort since they do not have to be rigidly mounted and stiffened to absorb reactions of braking and acceleration.

REAR AXLE

The rear axle, having a tread of $59\frac{1}{2}$ inches, is of the three-quarter floating type with special alloy steel axle shafts and gears. A three-quarter floating design makes it possible to obtain a permanent and quiet connection between the axle shaft and the

wheel without causing great bending stresses in the shafts. This axle is not depended upon to support the weight of the car in addition to carrying the extreme torque loads to which it is subjected. The ring gear is mounted on large adjustable tapered roller bearings, meshing with a pinion mounted in ball bearings with a double row bearing to carry the thrust loads. These gears are individually matched to secure perfect tooth contact and are tested in silent rooms for quiet operation. The differential is covered by a large removable plate, making for accessibility in service.

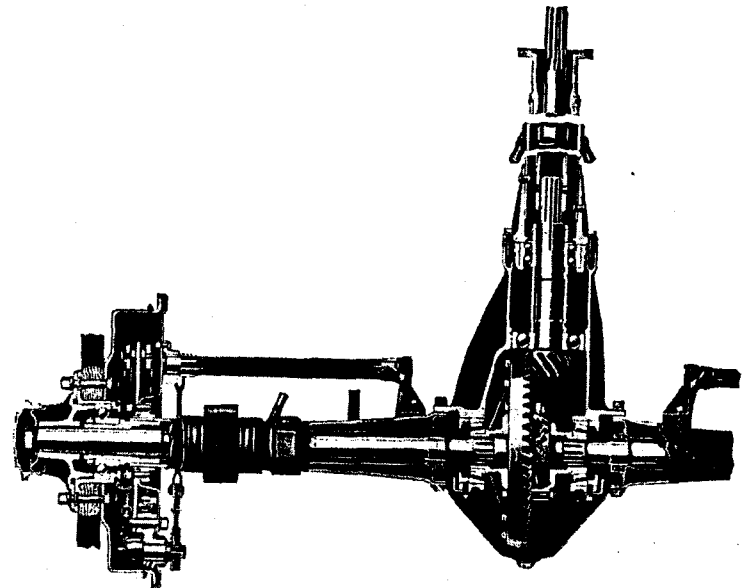

The three-quarter floating axle of the Cadillac relieves the shaft of excess bending stresses and provides a permanent and quiet connection between the shaft and wheel. The gears have generous tooth areas for quiet operation. Bearings are large and insure accurate alignment.

FRONT AXLE

The front axle is of the reverse Elliott type, having a tread of 59 inches, with steering spindles mounted on adjustable ball bearings. The positions of the axle and steering spindles have been designed to provide easier steering at all times with the maximum of safety. A parallel rod is mounted at the rear of the axle with self-adjusting ball-and-socket joints at each end.

Safety-mechanical four-wheel brakes

Obviously, great power and high speed are not desirable unless they may be readily controlled under all conditions with a minimum of effort. In 1928, Cadillac engineers introduced a new design of safety-mechanical four-wheel brakes of the internal shoe type which embody several exclusive features. These brakes are of simple but rugged construction, and give a sense of dominating control, absolute safety, and mental ease never before experienced. Their ease of application and effective operation particularly appeal to women drivers.

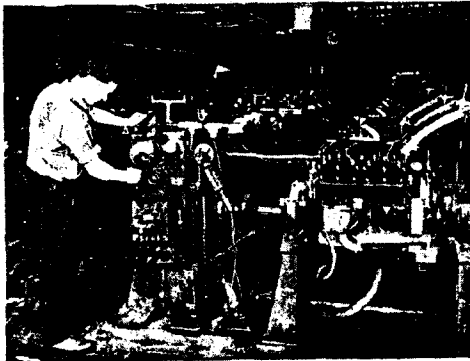

Each completed Cadillac power plant is tested in this dynamometer room by skilled operators for fine performance. Before leaving this room, the engine is partially disassembled, inspected, and readjusted

Two pairs of service brakes, operated by the brake pedal, act upon

The perfect balance of the Cadillac power plant is preserved by carefully balancing each part rotating with the flywheel. The clutch assembly is tested for balance on this machine and corrections for unbalance are made at the proper point



brake drums 16½ inches in diameter simultaneously upon all four

wheels and in proper ratio to assure maximum braking efficiency in any kind of weather, or with any road surface condition. The hand brake operates on the rear wheels giving a parking and emergency brake.

Each brake consists of a pair of articulated shoes operated by a floating cam. These shoes are cast from aluminum alloy, insuring remarkable rigidity, and have exceptional depth of web. The brake lining gives unusually long life since the cams which operate the shoes are not stationary and can, accordingly, center themselves to compensate for unequal wear which is so noticeable in other cam-operated shoe brakes.

Because of the articulated shoe construction "toe" or "heel" contact is eliminated, and the wrapping action either in forward or reverse motion is so uniformly distributed that seizing brakes are an impossibility. The articulated shoe has another advantage in that the whole braking area is effective at all times—which is not possible with the other types of construction—and, consequently, the brakes will not overheat with a change of pedal position when descending

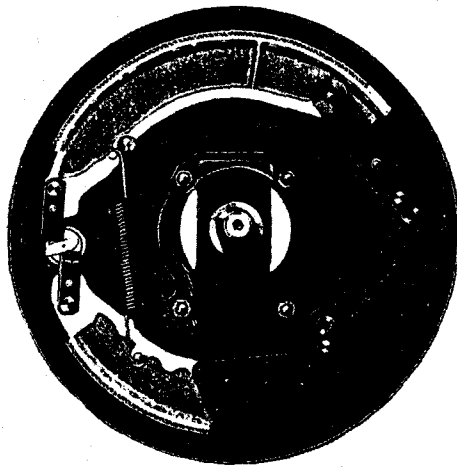

A—Front brake mechanism

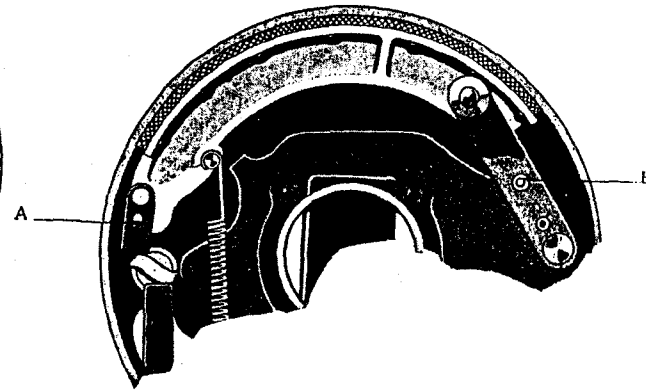

B—Links A and B insure that the brake shoe makes full contact at all times

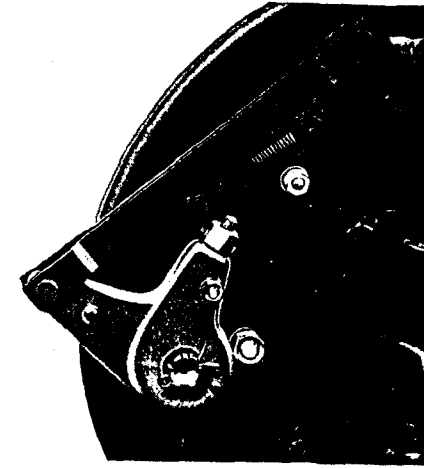

C—Brake adjustment mechanism

THE CADILLAC SAFETY-MECHANICAL FOUR-WHEEL BRAKES

The safety-mechanical brakes introduced by Cadillac in 1928 are based on sound engineering and careful application of the basic laws and principles of mechanics to the problem of decelerating a rapidly moving automobile. When one considers the power necessary to accelerate a car to 60 miles per hour, it is apparent that an equal power must be dissipated in the brakes to produce the rapid deceleration necessary in our present congested traffic. The energy thus dissipated is turned into heat, where it normally tends to produce severe distortion of the brake parts which would tend to mar the performance of any brakes which are not designed on correct engineering principles. The exclusive feature of the Cadillac safety-mechanical four-

wheel brakes is the articulated link which will always align itself with the resultant of all the forces acting upon the brake shoe at any given time. The force exerted by the cam combines with the resultant of all the frictional forces producing a force which is always parallel to this link. This eliminates completely "toe" or "heel" contact, making all braking area effective and giving a remarkable degree of self-energization. This link also permits a change in the position of all brake parts to counteract the expansion which accompanies the necessarily high temperatures attained in braking. This realignment of the brake parts with temperature assures the same uniform braking action under every driving condition.

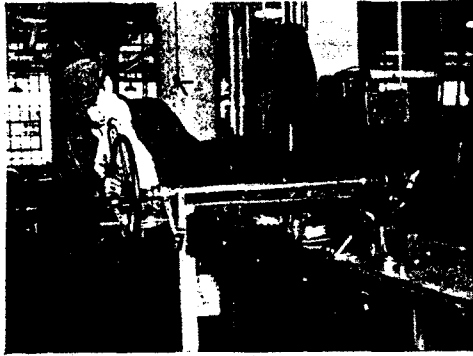

Cadillac steering gear assemblies are inspected for satisfactory operation and ease of control by these sensitive gauges before being installed in a car

through friction in the system before actually reaching the brakes. The Cadillac braking system, by the unique use of fifteen sets of roller bearings, has prevented this loss to a hitherto unprecedented degree. This fact, together with the scientific design of the brakes, results in the astonishing ease with which the brakes are operated. No other motor car manufacturers employ roller bearings throughout their brake construction.

Apart from their remarkable efficiency, these new Cadillac-designed brakes present decided advantages by being wholly enclosed within the drums, thus avoiding the usual troubles caused by mud, water, etc. The rods and cables which operate the brakes have been so designed that the braking action remains entirely unaffected over the roughest roads. Adjustment, when required at infrequent intervals, is effected by a single nut on each wheel which is easily accessible from the outside.

long grades. A coil spring encircles each drum to dissipate heat and to muffle noise. Lead tips are provided on the long shoes to pick up any particles which may score the drums.

It is an established fact that in braking systems at least 50 per cent of the foot pressure applied by the driver is lost

SPRINGS

The springs are one of the most important units in that they make easy riding an actuality. Cadillac spring suspension is of the semi-elliptic type with extremely long and flexible springs under-slung at the rear, giving a lower center of gravity without sacrificing head room. The total spring length on each side is 102 inches which represents 73 per cent of the 140-inch wheelbase. The spring leaves are forged from silico-manganese steel, accurately heat-treated for maximum life. An unusual feature is a special design for the ends of the leaves, permitting them to slide over one another without digging into each other. Different springs are employed for different body styles to give perfect riding under all conditions.

The rear springs, having been relieved of all driving forces by the torque tube, are shackled at both ends with shackles of the tension type. The rear shackles of the front spring are of a special design which adds materially to the riding qualities of the car. Duo-draulic shock absorbers are fitted to each spring, controlling their action and adding wonderfully to the remarkable riding qualities of the new Cadillac. All springs are protected by spring covers packed with petrolatum, insuring perfect lubrication and quiet operation at all times.

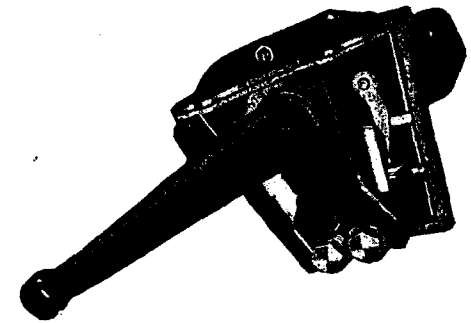

Duo-draulic shock absorbers fitted to each spring provide dampening with the proper ratio for direct action and rebound at all times.

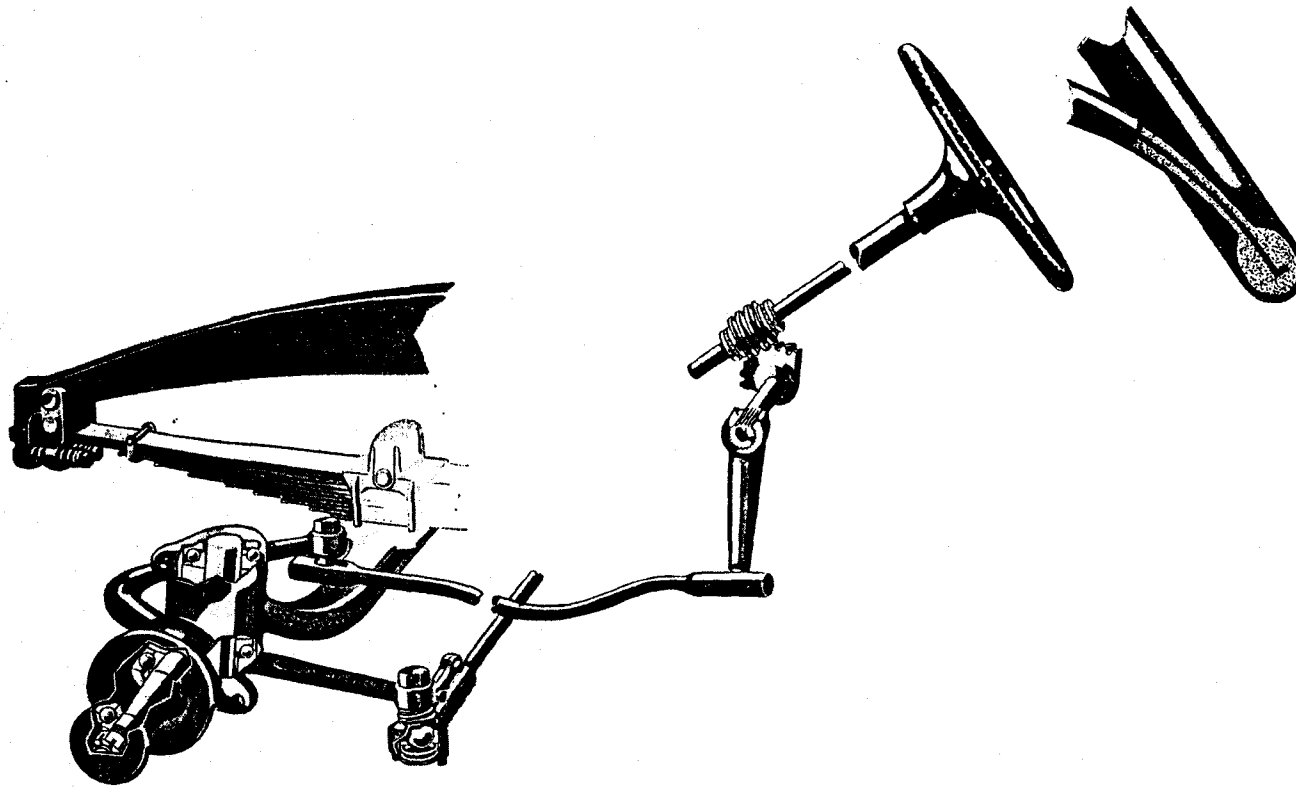

THE COMPLETELY HARMONIZED STEERING SYSTEM

Cadillac's completely harmonized steering system brings a new ease of control, a sense of security and safety into the pleasures of driving. This steering system has been planned and designed as an entity so that all units work together harmoniously, giving safety and ease of control with a minimum of effort. A steering modulator at the forward end of the left front spring eliminates all tendency for wheel shimmy by neutralizing gyroscopic forces

set up in all automobiles at high speeds. Ball bearings are used throughout the steering system to eliminate friction. Long life has been secured by the use of a nitralloy sector made from one of the hardest metals known to present science. Safety has been further considered by incorporating an unbreakable steering wheel made from die cast aluminum reinforced with steel, eliminating the hazard of personal injury from the breaking of a wheel in a bad crash.

Completely harmonized steering system

One of the first things that will be observed in driving the new Cadillac is the exceptional ease with which the car may be controlled at all speeds on any kind of road. The steering gear, itself, is of the worm and sector type, providing a reduction of 14 to 1. The worm is supported in the housing by large bronze bushings to take all radial loads, and adjustable ball bearings are provided for thrust loads. The sector is machined from a forging of nitraloy steel, a new metal having great hardness and resistance to abrasion.

The steering system has been completely harmonized by a steering modulator, a new and important feature, at the forward end of the left front spring, consisting of a flexible shackle held by four coil springs to completely cancel the effects of front wheel shimmy and tramp at all speeds and on any type of road surface. This enables the car to be operated at high speeds under all conditions



Oil pans, splash pans, and other sheet metal parts are slumped by giant presses to their correct form.

without fatigue and effort in driving.

The steering wheel is of a new safety design, completely eliminating the hazard of personal injury resulting from the breaking of the wheel in a bad crash. It is an aluminum die-casting reinforced with steel, the rim of which will not part

from the spokes regardless of the impact; and it is impossible for a spoke to break and injure the driver. The wheel is 19 inches in diameter finished in pyralin, giving a durable and attractive luster to this unit. The throttle and headlight controls are placed in the center of the wheel as formerly, but are of a new and distinctive design so shaped that they will not tear the driver's clothing in a quick maneuver.

FRAME

The foundation supporting all of these units and upon which the body is mounted is the frame. In buildings where accurate machinery is to be installed, the required rigidity of the floors imposes a more exacting condition upon the design of beams and girders than is imposed by the requirement of safety alone. Cadillac engineers have not been content to allow only an ample factor of safety in the design of the

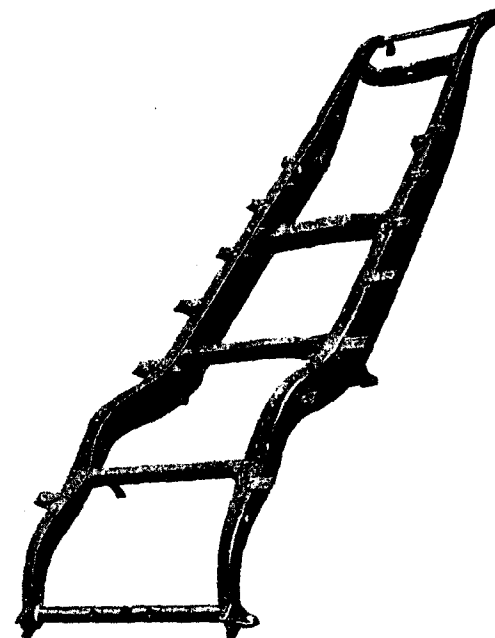

The Cadillac frame, with a 9-inch depth, provides tremendous strength and rigidity with consequent freedom from annoying body noises likely to result with frames of insufficient depth.

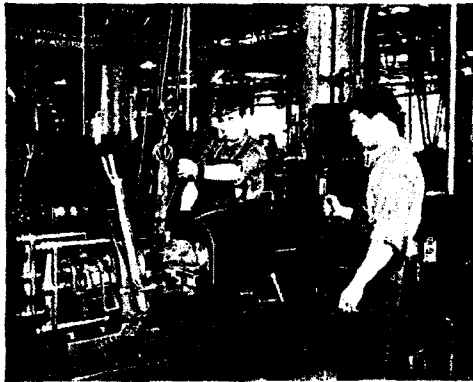

Each Synco-Mesh transmission is tested on this machine where gears are shifted from high into second at high speeds to assure complete synchronization. This assures quietness and ease of control

section has the unusual depth of 9 inches, with a flange width of $3\frac{1}{4}$ inches on top and $2\frac{5}{8}$ inches below. There is also a gradual reduction in this section toward each end with "kick-ups" over both front and rear axles. The side bars are rigidly tied together by six cross-members; a central cross-member of channel section; a cross-member below the radiator supporting it as well as the forward engine support; a channel cross-member opposite the front ends of the rear springs; a channel cross-member at the rear of the body, supporting the gasoline tank; and two tubular cross-members, one at the front and one at the rear outriggers.

It is axiomatic among engineers that a tubular member is the lightest possible type for resisting torsional and indeterminate bending stresses. The difficulty of anchoring tubular braces has been overcome in the Cadillac frame by the use of brackets into which

frame, but have reduced deflections to a minimum, thus relieving the engine and body from twisting strains, insuring longer life and eliminating body noise.

The side bars are of $\frac{5}{8}$ -inch channel section throughout, having an unusually wide top flange, with the greatest depth at the center where the stress is most severe. This

the splined ends of the tubular members are pressed. The application of splined joints will be recognized as unique in frame construction and highly advantageous.

WHEELS

Four types of wheels are available: Wood, demountable wood, wire, and disc. The diameter of all wheels is 19 inches. Wood wheels, which are standard equipment, have demountable rims of the split type while the rims are integral with the other three types of wheel. An extra charge is made for the demountable wood, wire, and disc wheels.

Wire wheels are designed to offer unusual lateral strength. They are retained on their hubs by cap screws which are concealed by large, ornamental hub caps. Disc wheels are built with a double curve of such proportions as to insure resiliency and freedom from rumble. Demountable wood wheels are built to approximately the same design as the standard wood wheels, but differ in their hubs so as to permit their being removed readily. The standard tire size with which wheels of all types are equipped is 7.00-19 inches.

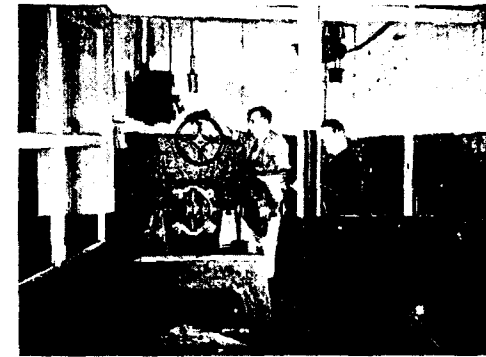

Rear axle assemblies are tested under load in silent rooms where outside noise is completely eliminated, permitting gear noise to be readily detected. Tooth contact is examined and a complete record made of each assembly before it is released to enter a car

INBUILT SUPERIORITY

Thus by thorough mastery of an infinity of technical details Cadillac achieves the height of luxury in motoring. Its superiority is inbuilt, residing in correct design of units, precise accuracy in building them, and efficient functioning of every part.

Only on the basis of these fundamental facts of design and construction can a motor car be wisely selected today. To neglect them is to incur the risk of failure to obtain all that fine motoring in the modern sense can supply. For smooth, proficient performance month after month, year after year, can be gained only when the engineering of all units is faithfully attended to by talented and sincere men.

Long life, too, can be assured only by building strength, efficiency, and dependability into individual units as Cadillac here describes them. Because Cadillac has held squarely to this creed

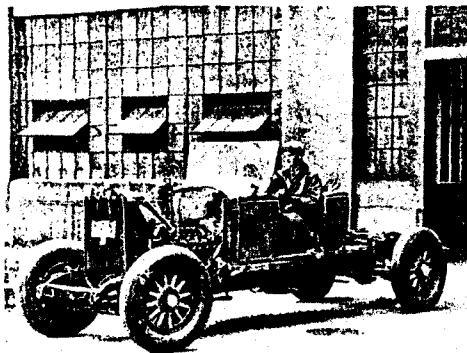

The finished chassis equipped with this test body is given a complete road test before the body is mounted, so that any flaw may be corrected and perfect operation insured

for a quarter of a century, Cadillac today commands the unqualified respect of discriminating motorists everywhere. Cadillac performance, Cadillac luxury, Cadillac beauty, Cadillac reliability have become traditional throughout the industry.

The Cadillac engine type, the famous 90-de-

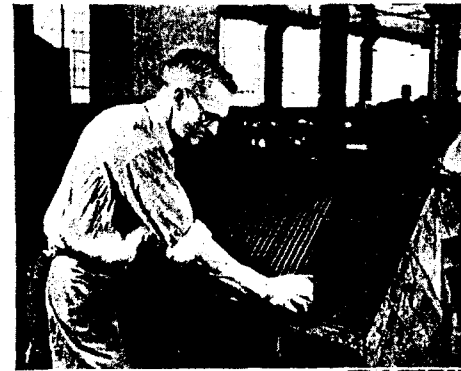

The high luster of Cadillac bodies and hoods is obtained by hand rubbing. This gives a lasting and perfect finish not obtainable in cars where quality is not the dominant consideration



gree, V-type eight, remains today after years of vigorous competition the smoothest, quietest, simplest, and most compact power plant yet developed for a fine motor

car. More than ever before the V-type proves itself the engine principle of the future. Speed records on land, sea, and air are held by engines of this type. The Graf Zeppelin is powered by a V-type engine. And the growing preference for multi-cylinder engines in all fields of service is rendering ever wider application of the V-type principle inevitable.

These pages describe the units by which Cadillac performance and long life are attained. They cannot describe that performance itself. But you can experience it. Your Cadillac dealer will gladly supply a car for your use in acquainting yourself with motoring luxury in its most modern interpretation.

CONDENSED SPECIFICATIONS—CADILLAC 353

POWER PLANT

ENGINE—Compensated eight-cylinder, V-type. Ninety-degree angle between cylinder blocks. Engine and transmission in unit; three-point suspension with rubber-lined supports at rear. Piston displacement 353 cubic inches. Bore $3\frac{3}{8}$ inches. Stroke $4\frac{1}{8}$ inches. Horsepower N.A.C.C. rating 36.45; actually more than 95.

CRANKCASE—Silicon-aluminum alloy, specially treated.

CRANKSHAFT—Diameter $2\frac{3}{8}$ inches; length to outer ends of front and rear bearings $23\frac{3}{4}$ inches. Supported on 3 main bearings. Crank throws 90 degrees apart, provided with compensators.

CYLINDERS—Cast in blocks of four, with detachable heads. High-compression heads standard, low-compression optional.

PISTONS—Cast nickel iron, special formula, annealed; 4 rings, 3 above wrist pin and 1 below; lower ring special oil regulating type.

CONNECTING RODS—Drop-forged special formula steel. Side by side, two on each crank pin. Rods are gun-drilled for pressure lubrication of wrist pins. Bearings $2\frac{3}{8}$ inches by $1\frac{1}{8}$ inches. Babbitt in rods at lower ends.

CAMSHAFT—Single, hollow shaft with 16 cams, supported on 4 bearings. Driven from crankshaft by silent chain.

VALVES—Intake $1\frac{5}{8}$ inches clear, tungsten steel; exhaust $1\frac{3}{8}$ inches clear, silico-chrome steel, $\frac{3}{4}$ -inch lift. Mechanism enclosed. Valve stems automatically lubricated. Valves are unmasked.

GASOLINE SYSTEM

CARBURETOR—Cadillac design and manufacture. Uniform distribution, with maximum efficiency and economy. Automatic thermostatic mixture control. Large accessible strainer. Overflow from carburetor drained to ground. Intake header exhaust-heated. Valve in left exhaust manifold automatically operated, when closed deflects exhaust gases back from left cylinders through intake header jacket to the right exhaust manifold, thus giving maximum heat for carburetor almost immediately after starting.

SUPPLY—Twenty-five gallon tank. Vacuum feed. Vacuum from intake manifold assisted by vacuum created by a special vacuum pump to insure positive feed under all conditions.

COOLING SYSTEM

WATER COOLING—Capacity $6\frac{1}{4}$ gallons. Forced circulation by one pump driven by a silent chain from the crankshaft. Cylinder blocks interconnected by a brass tube cast in crankcase. One drain plug for entire system.

TEMPERATURE CONTROL—Thermostatically controlled by radiator shutters with vertical balanced shutter blades.

RADIATOR—Copper with cellular core. Casing chromium-plated on polished nickel.

FAN—Diameter 21 inches; 6 blades; belt driven by pulley mounted on end of camshaft. Fan bearing automatically lubricated from main supply of engine.

LUBRICATING SYSTEM

ENGINE LUBRICATION—Pressure system with gear pump conveys oil under pressure to all main bearings, connecting rod bearings, wrist pins, camshaft bearings, and fan pressure is controlled by an automatic pressure regulator. Oil level indicator is located on right-hand side of crankcase at rear.

CRANKCASE VENTILATION—An exclusive Cadillac system which prevents dilution of lubricating oil from unburned gasoline and from condensation of water vapors produced in combustion.

OIL FILTER—An effective filtering device which removes from the oil any impurities in solid form.

ELECTRICAL SYSTEM

IGNITION—Cadillac-Delco high-tension system with 2 timer contact arms actuated by 4-lobed cam. Jump-spark distributor.

IGNITION LOCK—Coincidental theft-proof ignition and transmission lock operated from instrument board.

GENERATOR—Two-pole Cadillac-Delco type, mounted on right side of engine. Positive drive by chain from crankshaft. Thermostatic and third brush control of charging current.

STARTING MOTOR—Cadillac-Delco separate 4-pole unit; double reduction between motor and flywheel. Mounted along right side of transmission.

BATTERY—Cadillac-Exide 130-ampere hour, 6-volt, 3-cell. Moulded case located in right-hand dust shield.

HORN—High-frequency vibrator horn of exceptional tone carried on left headlamp bracket at side of radiator. Concealed connections.

LIGHTING EQUIPMENT—Two headlamps with tiltable light beams controlled from steering wheel, fluted lenses, 21 c.p. double-filament bulbs, and parking lamps with 3 c.p. bulbs. Parking lamps mounted on top of front fenders. Two rear lamps, one located on each rear fender. Stop lights in dust shields which light automatically with opening of doors.

OPERATING CONTROLS

CLUTCH—Dry disc plate type. Two steel driven discs 10 inches in diameter faced both sides with compressed asbestos fabric, driven by cast iron plates to which are attached all springs, levers, and other parts of clutch, with exception of clutch thrust bearing, which is supported by a sleeve bolted to the transmission case.

TRANSMISSION—Special Cadillac Syncro-Mesh transmission, giving noiseless, smooth gear shifting at all speeds. Selective type with three speeds forward and one reverse. Nickel steel gears and shafts. Faces of gear teeth ground on special grinding machine to obtain silent operation. Mechanism contained in cast iron case.

GEAR SHIFT—Center gear shift.

SERVICE BRAKES—Safety-mechanical brakes. Special design. Entirely enclosed, giving maximum efficiency in all weather. Mechanically operated, in-

ternal on both front and rear wheels. Division of pedal pull automatically proportioned between front and rear systems. Front brakes equalized when straight ahead, outer brake released on turn. All brakes are 16½ inches in diameter.

HAND BRAKES—Internal, on rear wheels.

STEERING GEAR—Cadillac design, worm and sector, completely adjustable. Reduction 14 to 1. Steering wheel, 19 inches in diameter, of special safety type employing a die cast aluminum rim and spider with steel reinforcement, pyralin finish. Steering system completely harmonized by means of special modulator at the forward end of the left front spring consisting of a flexible shackle held by four coil springs, completely eliminating all shimmy, front end tramp, and road shocks.

ENGINE CONTROLS—Accelerator at right of brake pedal. Hand throttle built into central portion of steering wheel.

MISCELLANEOUS

AXLES—Rear axle, Cadillac make, ¾ floating with special alloy steel axle shafts and gears. Spiral bevel gears mounted on large bearings. Front axle, reverse Elliott type, drop-forged steering spindles and arms; steering spindles have adjustable bearings at both ends. Parallel rod has spring compensated ball-and-socket connections at end.

DRIVE—Hollow steel drive shaft 2½ inches diameter in center, tapering to 2¼ inches at each end, turns in torque tube, which completely seals assembly. Rear end of drive shaft rigidly connected to rear axle by splined sleeve; front end to transmission shaft through universal joint. Torque tube is bolted to differential carrier at rear, and front end pivoted in ball-and-socket joint at rear of the transmission. Transmits drive of rear wheels to chassis and absorbs torque reactions due to acceleration and brakes.

FRAME—Side bar channel section with wide top flange, carbon steel, maximum depth 9 inches, width 31¼ inches in front, 36½ inches in rear; flange width at top 3¼ inches, at bottom 2¼ inches.

SPRINGS—Semi-elliptic system of suspension with rear springs under slung. All shackles of rear springs tension type. Front springs 42 inches by 2¼ inches; rear 60 inches by 2½ inches. Double-action shock absorbers of hydraulic type, front and rear, with both upward and downward dampening action, give greatly improved riding qualities.

GEAR RATIO—Standard 5.08 to 1. Optional 4.75 to 1 and 4.39 to 1.

WHEELS—Artillery type, 12 hickory spokes with steel felloe. Adjustable ball bearings at front, demountable hot-rolled split-type rim with 6 lugs. Large steel hub with 12 bolts. Disc, wire, or demountable wood wheels obtainable at additional cost.

TURNING RADIUS—At tires: Right 24 feet, 7½ inches. Left 25 feet.

WHEELBASE—140 inches. Tread rear 59½ inches. Front 59 inches.

TIRES—7.00-19.

TOOLS—Complete set of tools in special fabric holder, placed in rain-proof box, concealed in left-hand dust shield. Power tire pump on transmission.

INSTRUMENT BOARD—Instruments arranged in individual assembly. Fitted with windshield wiper control, spark control, oil pressure gauge, button controlling carburetor enriching device, switch for instrument board lighting independent of switch on steering column, speedometer, ammeter, electrically operated gasoline gauge, eight-day clock, coincidental transmission and ignition lock, engine temperature indicator, and combination inspection lamp and cigar lighter.

FENDERS—One-piece, full crown, wide type.

SECURITY-PLATE GLASS—Is fitted in all models both open and closed, for windshields and body windows.

BODY STYLES

The seven Fisher Custom bodies are:

Two-Passenger Coupe	Five-Passenger Sedan
Two-Passenger Convertible Coupe	Five-Passenger Town Sedan
Five-Passenger Coupe	Seven-Passenger Sedan
	Seven-Passenger Imperial Sedan

FLEETWOOD SPECIAL CUSTOM BODIES

The fourteen Fleetwood Special Custom bodies comprise the following styles:

Cadillac-Fleetdowns.....	Two-Passenger Roadster
Cadillac-Fleetway.....	Four-Passenger All-Weather Phaeton
Cadillac-Fleetwind.....	Four-Passenger Sedanette Cabriolet
Cadillac-Fleetwind.....	Four-Passenger Sedanette
Cadillac-Fleetdene.....	Five-Passenger Sedan
Cadillac-Fleetmere.....	Five-Passenger Sedan Cabriolet
Cadillac-Fleetdene.....	Five-Passenger Imperial
Cadillac-Fleetmere.....	Five-Passenger Imperial Cabriolet
Cadillac-Fleetdale.....	Seven-Passenger Sedan
Cadillac-Fleetdale.....	Seven-Passenger Imperial
Cadillac-Fleetwick.....	Town Cabriolet with Opera Seats
Cadillac-Fleetmont.....	Town Cabriolet with Quarter Window
Cadillac-Fleetcrest.....	Town Cabriolet with Full Rear Quarter
Cadillac-Fleetbourne.....	Limousine Brougham

The Cadillac Motor Car Company reserves the right to make changes in specifications at any time without incurring any obligation to install same on cars previously sold

GENERAL MOTORS DEFERRED PAYMENT PLAN



The purchase of a motor car out of income is an established custom. Cadillac-LaSalle dealers welcome business on this basis. Should you wish to buy a Cadillac or LaSalle car by monthly payments instead of full payment at the time of purchase, the Cadillac Motor Car Company provides the General Motors deferred payment plan.

This plan is a banking service which enables you to enjoy a Cadillac or LaSalle while you pay for the car out of income. Cadillac-LaSalle dealers will gladly accept your present car at its full market value. It is probable that this value will be sufficient to take care of the down payment and reduce the monthly payments. The purchase of a new Cadillac or LaSalle under the General Motors Acceptance Corporation Plan may be arranged as follows:

<i>Model</i>	<i>*Delivered Price</i> \$
<i>Equipment</i>	<i>Credit for your car</i>
.....	(Good until) \$
	<small><i>Date</i></small>
.....	<i>Cash Down Payment</i> \$
.....	<i>Total Down Payment</i> \$
.....	<i>Deferred obligation for</i> \$
.....	<i>Payable at the rate of</i> \$ <i>per month</i>
	<i>until paid.</i>

**NOTE: "Delivered Price" includes the GMAC charges together with Fire and Theft Insurance*

All fenders and chassis black.

In addition, Fleetwood bodies in a variety of rich colors, lighter in shade, will be brought through periodically for stock. Bulletins will announce these.

Colors available on open types, All-Weather types, and Sedanette types will be announced periodically.

UPHOLSTERY

EIGHT rich exclusive Fleetwood Doeskin Suede broadcloths by Wiese in subdued colorings harmonizing with any exterior color.

Exclusive Fleetwood Wiese broadcloths:

- Weise 2969 - - - - - Green Gray
- Weise 2970 - - - - - Maroon Taupe
- Weise 2971 - - - - - Tan
- Weise 2972 - - - - - Silver Gray
- Weise 2973 - - - - - Blue Gray
- Weise 2994 - - - - - Tan Taupe
- Wiese 3288 - - - - - Dark Gray
- Wiese 3363 - - - - - Dark Taupe

Optional in all enclosed drive and transformable types.

Three special Venetian mohairs of short nap.

Exclusive Fleetwood Venetian mohairs:

- 108-T - - - - - Green
- 109-T - - - - - Gray
- 110-T - - - - - Taupe

Optional in all enclosed drive and transformable types.

The first two blend well with complementary body colors, Taupe, because of its neutral shade, going well with any color.

Fifteen special exclusive Fleetwood Aero leathers by Radel. These are lightweight, soft, pliable, and luxurious, four being specified for stock with the balance optional without extra charge, with a reasonable added time allowance.

Special Radel Aero leathers:

- 5885 - - - - - Silver Gray
- 451 - - - - - Pearl Gray
- 2646 - - - - - Blue Gray
- 5897 - - - - - Green Blue
- 68 - - - - - Blue (Standard)
- 6016 - - - - - Dark Blue
- 9205 - - - - - Deep Maroon
- 5875 - - - - - Rich Maroon
- 4339 - - - - - Green (Standard)

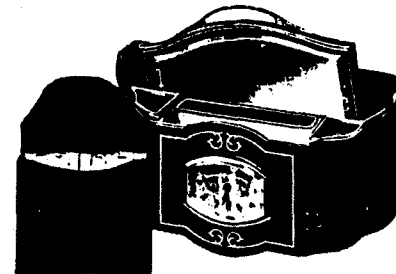

Vanity cases are designed exclusively for Fleetwood bodies and contain 8-day clock, mirror, leather cigarette case, and two ash receivers

6019	- - - - -	Soft Green
6012	- - - - -	Dark Green
9128	- - - - -	Light Brown
9131	- - - - -	Dark Brown
743	- - - - -	Tan (Standard)
2645	- - - - -	Black (Standard)

Optional in All-Weather Phaeton, Sedanette, and open types.

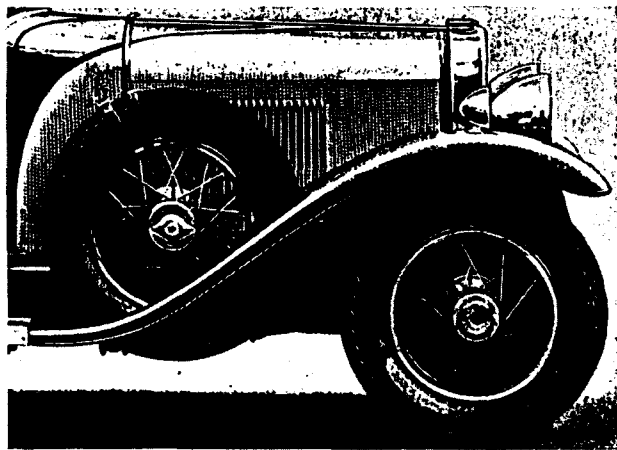

This picture shows a hood with damaskeen finish, a unique and attractive treatment

Six weatherproof Bedford cords by Wiese. The corded fabrics are used for seats with plain material to match for head linings. The waterproof feature of these materials makes them especially desirable for All-Weather types.

Special waterproof Wiese Bedford cords:

Wiese 2659-F, 2759-F	- - - - -	Green Gray
Wiese 2661-F, 2761-F	- - - - -	Brown Gray

Wiese 2662-F, 2762-F	- - - - -	Gray
Wiese 2663-F, 2763-F	- - - - -	Blue Gray
Wiese 2665-F, 2765-F	- - - - -	Maroon Taupe
Wiese 2666-F, 2766-F	- - - - -	Tan Taupe

Optional in All-Weather Phaeton and Sedanette types.

With the wide variety offered in the regular exclusive Fleetwood upholstery materials, we recommend that cloths be selected from Wiese collection No. 61 *only when absolutely necessary*, as there will be delays involved in securing curtains and other trimming materials to match. These delays are avoided in the case of the regular Fleetwood materials.

Enclosed drive types and transformable types.

Eight exclusive Fleetwood Wiese broadcloths—optional.

Three exclusive Venetian mohairs—optional.

Any material in current Wiese Collection No. 61—optional.

All-Weather and Sedanette types:

Fifteen Fleetwood Radel Aero leathers—optional.

Six weatherproof Fleetwood Wiese Bedford cords—optional.

Open types:

Fifteen Fleetwood Radel Aero leathers—optional.

(In the case of All-Weather Phaetons, Sedanettes, and open types, four of the exclusive Fleetwood Radel Aero leathers in the sample book will be specified for stock. The balance are optional with reasonable added time allowance.)

The distributing organization has already been furnished with samples of the three exclusive Fleetwood Venetian mohairs available. The distributing organization will be furnished with sample books of the eight exclusive Fleetwood Wiese doeskins, the six special weatherproof Wiese Bedford cords and the fifteen exclusive Fleetwood Radel Aero leathers as soon as such books are available.

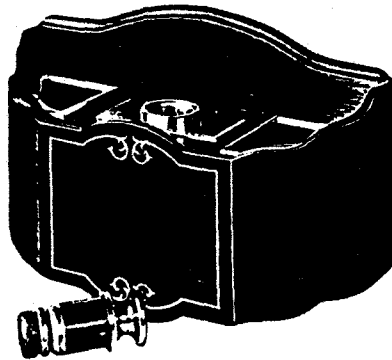

Smoker's set has inlaid case, with removable cordless lighter, and two ash receivers

EQUIPMENT

Equipment common to all body styles of each type (Sedans, Town Cabriolets, etc.) is found on pages 18 to 24. Equipment exclusive to each individual body style is listed on the page facing the illustration of that body style.

Wiring for radio installation is included in all body styles except 3902, 4002, 4060, 4057.

BODY STYLE OPTIONS

The four Town Car models—Fleetwick, Fleetmont, Fleetcrest, and Fleetbourne—can be had with collapsible rear quarters. Fleetwick, Fleetmont and Fleetcrest in stock, Fleetbourne to order.

Extra charges are:

Style 3912-C	- - - - -	\$750
Style 3920-C	- - - - -	800
Style 3925-C	- - - - -	750
Style 3991-C	- - - - -	800

The same feature can be had on all Sedans and Imperials for the following extra charges:

Style 3975-C	- - - - -	\$800
Style 3975-SC	- - - - -	800
Style 3930-SC	- - - - -	800
Style 3930-C	- - - - -	800
Style 3955-SC	- - - - -	750
Style 3955-C	- - - - -	750

Note: Prices apply *only before* metal has been built on wood frame. If collapsible rear quarter is wanted on body already "in metal," individual price quotation is necessary. Delivery time—4 weeks additional.

<i>Back windows</i> —Special size or shape	- - -	\$125
<i>Quarter windows</i> —Special size or shape	- - -	250
<i>Leather quarters</i> — <i>Sedans and Imperials</i> —Non-collapsible leather quarters with landau bows, quarter windows retained. Three weeks additional time	- - - - -	250

Without quarter window (3975 or 3975-S only) three weeks' additional time	- -	\$300
Plain motor hood without raised panel (See page 86)	-	250
Sedanettes and Sedanette Cabriolet in special leather top material—Tan, grained to look like Burbank cloth	- - - - -	175
Opera seats—Instead of forward facing, in 3975, 3975-S, 3920, 3925, 3991	- - - - -	125
Concealed in 3912—lazyback omitted on left seat	- - - - -	200
In Five-Passenger Sedans	- - - - -	128

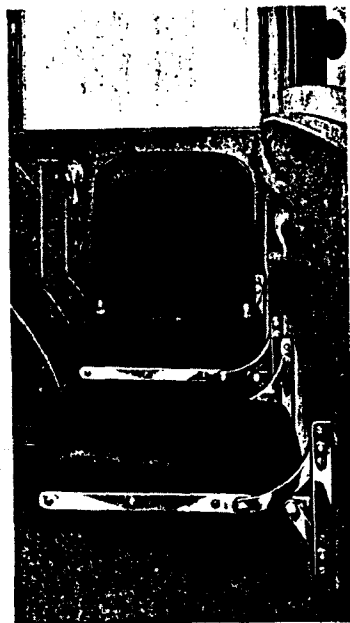

The Fleetwood "opera" seats, although designed for occasional use only, are remarkably comfortable. They are attached to the interior partition and fold up out of the way when not in use. As is shown, one seat faces the rear, the other with back, faces sideways. Seats are adjustable as to height

Sliding glass division—In Imperials and Town Cars with standard auxiliary seats	- - -	\$150
With concealed auxiliary seats	- - -	250
More head room—Providing 52 1/2 inches	- - -	650
Roof baggage rail—(Roof strengthening; painted or chromium rail)	- - - - -	425
Omitting glass division with stationary Sedan front seat—All-Weather Phaetons	- - - - -	200
Glass division, Sedanettes and Sedanette Cabriolets—between front and rear compartments	- -	200
Transformable driver's roof solid—Permanent	- -	275
Detachable—with flexible extra roof curtain	- - -	350
Full flush glass division for 3975 (Same as standard in five-Passenger Imperials Styles 3930, 3955)	- - -	150
Wheels—Wood is standard. Regular extra charges on Fisher Body cars apply on Fleetwoods for any special wheel equipment.		

Note: Prices apply only on cars not yet built up at Fleetwood factories.

No credit or allowance on regular equipment omitted.

COLOR OPTIONS

Color book—The Fleetwood Company has issued a color book containing samples of suggested colors which can be specified for cars in addition to the four colors shown on page 101.

Upper and lower panels—Any color. (Includes striping.)
No charge.

Fenders—Special colors at regular extra charges.

Colored leather quarters—For Cabriolets or Town Cars, Sedan and Imperial Cabriolet types; to match upper panels - - - - - No Charge

Damaskeen hoods—Engine turned finish - - - \$265

Varnish—Seven weeks additional for varnish finish, all body styles. No guarantee - - - 250

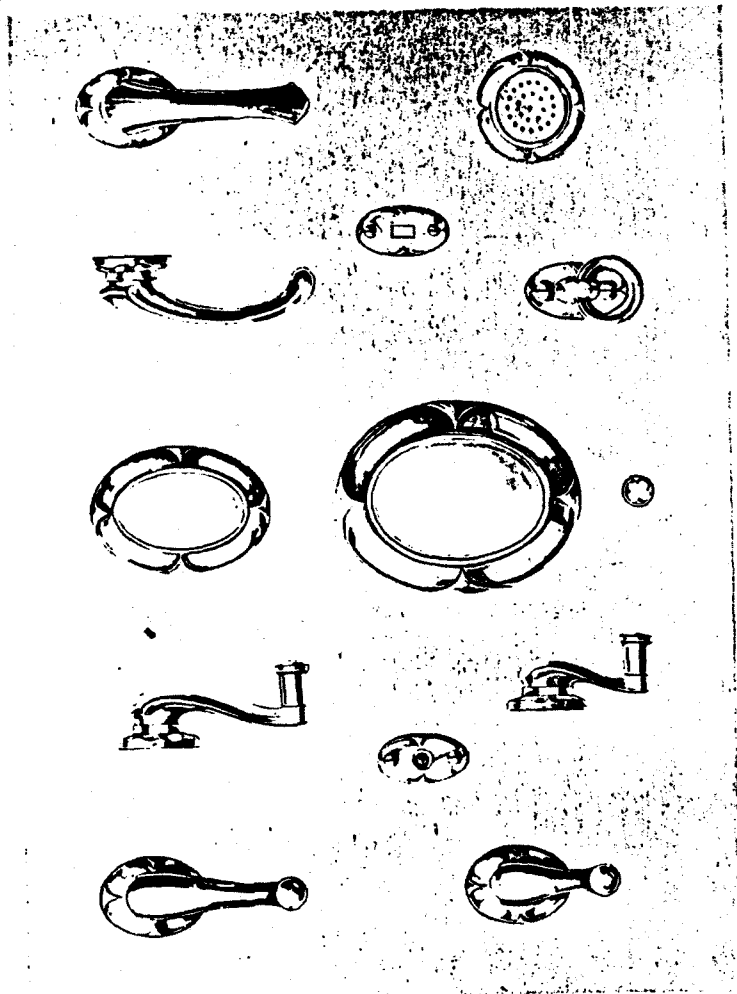

Hardware is created specially for the Fleetwood line, of beautiful design with chromium plated finish

UPHOLSTERY OPTIONS

See upholstery section, page 102.

Style—Tufted, pleated, etc., if ordered before body goes to Trim Department - - - - - No Charge

Special materials—Not included in Fleetwood broadcloths, mohairs, Bedford cords, Aero leathers or Wiese book, No. 61 - - - - - \$100

Needlepoint medallions, with broadlace on doors and divisions - - - - - 300

Leather—Transformables, Sedanettes, and enclosed drive types, front and rear cushions, balance broadcloth - - - - - No Charge

Seat cushions and up to belt - - - - - \$ 50

Entire interior, front and rear - - - - - 150

Colored, for All-Weather Phaetons, Sedanettes and open types (other than four standard colors) in Aero leather book, four weeks' additional time) - - - No Charge

Cushions—Any height, slope, or depth; provided orders are received before body goes into trim and standard seat box can be used - - - No Charge

Lap robes—Monogrammed, crushed plush backing - - - - - \$ 80 (Up)

Pockets—Flush type not possible. Envelope type attached on all doors - - - - - \$ 75

Down pillow—Not standard, if desired - - - - - 18

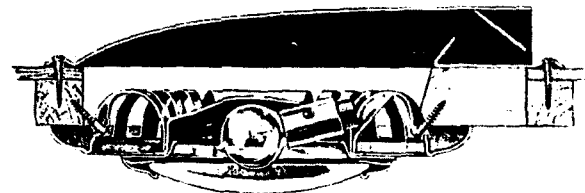

The handsome Fleetwood ventilating dome light not only illuminates the interior at night but ventilates the ceiling whenever the car is in motion

EQUIPMENT OPTIONS

<i>Foot rail</i> —Carpet-covered, to replace hassocks. (Must be ordered before body leaves factory) No charge	
<i>Mats</i> —Rubber for front compartment all types	\$ 18
<i>Linoleum</i> —Metal bound, front floor boards, all types	32
<i>Extra carpet</i> —For rear or front compartment	25
<i>Hardware</i> —Colored to match upholstery	25
Other finishes	\$ 25 (Up)
Special design	On Quotation
<i>Vanity and smoking sets</i> —For All-Weather and Sedanette types, attached to division	
Vanity	\$ 55
Smoking	26
Special finish	On Quotation
<i>Inside moldings</i> —To match vanity cases in special finish	\$ 35 (Up)
<i>Robe rails</i> —Bar and cord type can be interchanged after delivery without damage to upholstery. (Bar type cannot be used with opera seats.)	
Bar type Ducoed to match upholstery. (Must be ordered before body leaves factory. No charge	
Cord type to match upholstery. (Must be ordered before body leaves factory. - No charge	
<i>Ash receivers</i> —Flush type for front doors where not standard	\$ 15
<i>Division clock</i> —French walnut case	40

NOTE: All of the above extra charges are *list*, subject to special discount applying on extra charges covering special features on Fleetwood line.

Service

FLEETWOOD bodies are built with maximum care and close inspection in every detail of their construction to the end that the maximum of service and comfort will be rendered to every owner.

In addition to this careful manufacturing policy, service facilities have been arranged with the Fisher Body Corporation in order that all Fleetwood owners may have Fleetwood body service available in their respective communities. In addition to the parts depots in the factories at Detroit and Fleetwood, which service the East, Central West, and South, Fisher Body Corporation has a parts depot at Oakland, California, to service the Pacific coast country.

These facilities reduce the time element in correspondence and transportation to secure equipment necessary to restore the body to use.

There are also seven Service Headquarters located in New York, Detroit, Atlanta, Kansas City, Dallas, Minneapolis, and Oakland, from which points Fisher men operate, these men being thoroughly familiar with Fleetwood bodies and competent to properly make any repairs or adjustments.

excerpt from
The Book of Fleetwood
For 1930 Model Year

MOST INFORMATION SHOULD BE THE SAME FOR
1928-31 MODELS

GREG:

PLEASE USE THIS
INFORMATION ON
AN INDIVIDUAL
INQUIRY BASIS.
WOULD RATHER YOU
NOT COPY AND
RELEASE ANY OF
THE PAGES OR
COMPLETE LISTS
AT THIS TIME.



**Regular finish,
upholstery, and equipment**

ALL Fleetwood bodies are finished in Duco. Any color combination may be had at no extra charge. This is one of the strong sales appeals of Fleetwood.

In order that body styles may be kept in stock, certain color combinations have been selected as "stock" or regular. These are in the conservative shades which experience proves are most acceptable. These combinations will be used throughout the 1929-1930 season on the enclosed drive types and transformable types.

- 1—Duco Cromwell blue lower panels, hood, and window reveals.
Black upper panels and moulding.
Gold stripe.
- 2—Duco Mulberry maroon lower panels, hood, and window reveals.
Black upper panels and moulding.
Gold stripe.
- 3—Duco Alpinstock green lower panels, hood, and window reveals.
Black upper panels and moulding.
Cream stripe.
- 4—Duco Sable lower panels, hood, and window reveals.
Black upper panels and moulding.
Old ivory stripe.

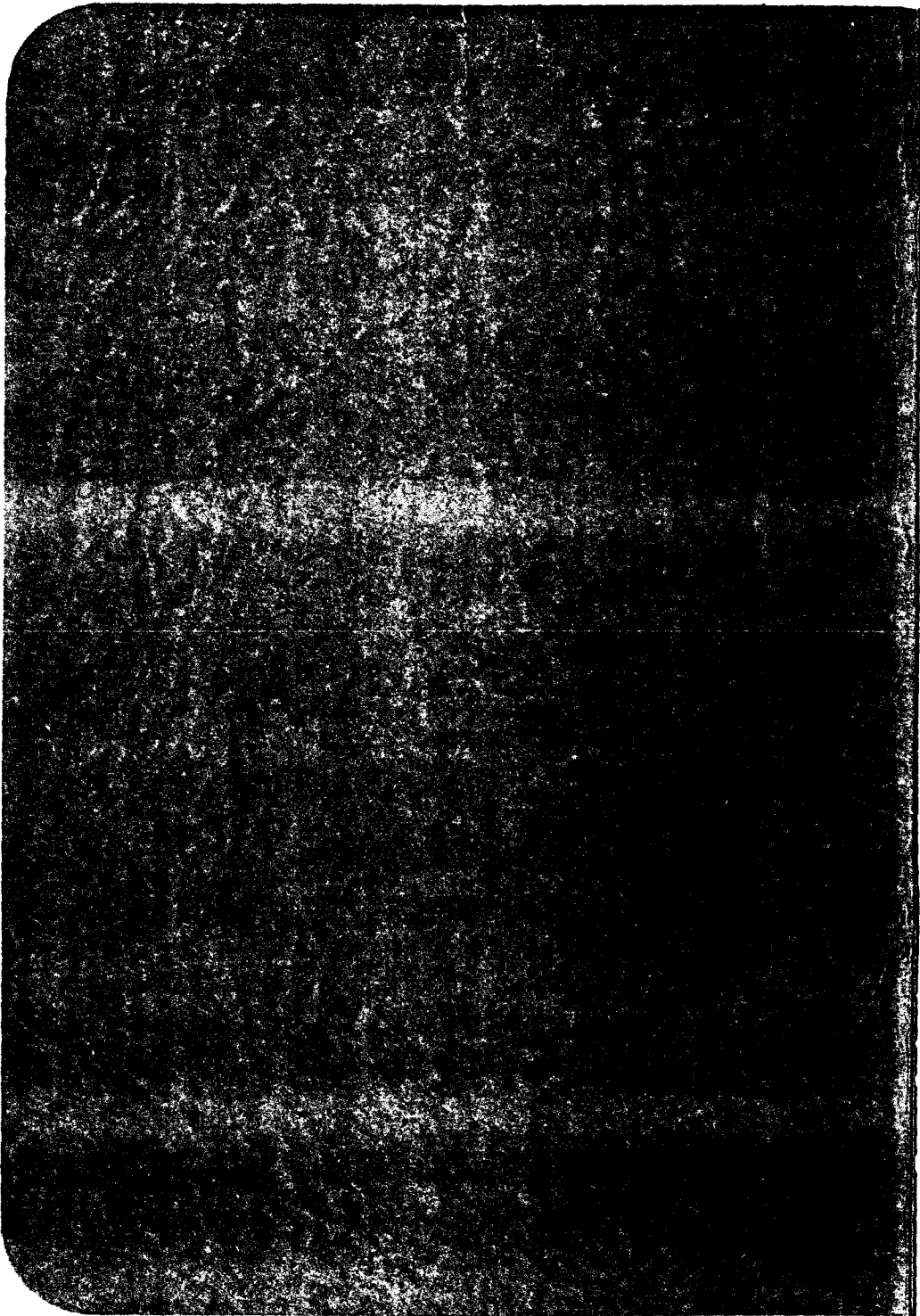

Copyright 1930 by
Cadillac Motor Car Company

EDITION NO. 355-1

*In ordering a duplicate of this Manual specify the
above number or the engine number of the car.*

Table of Contents

CHAPTER I— <i>Cadillac Service</i>	5
Cadillac-La Salle Service Stations—Service card—Service charges— Repair parts—The owner's obligation—Lubrication—Inspection.	
CHAPTER II— <i>Operation</i>	10
Locks—Ignition switch lock—Gasoline gauge—Throttle control— Carburetor choke control—Spark control—Starter pedal—Oil pressure gauge—Ammeter—Clutch pedal—Transmission control—Coasting— Brakes—Lighting switch—Danger of running engine in closed garage.	
CHAPTER III— <i>Equipment</i>	22
Windshield and ventilation—Windshield cleaner—Adjustable seats— Cigar lighters—Tools—TIRES—Inflation pressure—Spare wheel carrier —Spare tire carrier—Use of jack in changing tires—Changing tires— Tire balancing marks.	
CHAPTER IV— <i>Lubrication</i>	31
Lubrication schedule—Lubrication chart—LUBRICANTS—Engine oil —Gear lubricant—Chassis grease—Wheel bearing grease—Water pump grease—ENGINE LUBRICATION—Oil level—Crankcase ventilating system and oil filter—Replacing engine oil.	
CHAPTER V— <i>Cold Weather Operation</i>	38
PREPARING FOR COLD WEATHER—Anti-freezing solutions— Capacity of cooling system—Winter lubrication—Storage battery— Gasoline system—STARTING THE ENGINE—Choke button— Priming the carburetor—Position of throttle hand lever—Position of spark control—Use of starter—Use of accelerator before engine is warm.	
CHAPTER VI— <i>General Care</i>	45
Storage battery—Cooling system—Gasoline filter—Temporary brake adjustment—BODY—Care of finish—Care of the top—Cleaning up— holstery—Door hardware.	
CHAPTER VII— <i>Storing Car</i>	51
Engine—Storage battery—Tires—Body and top—Taking car out of storage.	
CHAPTER VIII— <i>Specifications and License Data</i>	54

No page 2

CHAPTER I

CADILLAC SERVICE

THE owner of a Cadillac car has purchased not simply a fine piece of machinery, ingeniously designed and carefully built—he has purchased a pleasant and dependable mode of transportation. The car itself is only one factor in securing this transportation—the other factor is Cadillac Service, which is built upon a *standard policy, clearly defined to the car owner and guaranteeing him efficient service everywhere at standard prices under factory regulation.*

Cadillac-La Salle Service Stations

Cadillac Service extends wherever Cadillac and La Salle cars are sold. Service stations conducted by Cadillac distributors and dealers are designated as "Authorized Cadillac-La Salle Service Stations" and are identified by the exclusive sign illustrated on this page. Wherever this sign is displayed, the owner will find an organization prepared to service Cadillac cars. This means proper equipment, factory trained personnel, a stock of genuine replacement parts and standardized policies and methods.

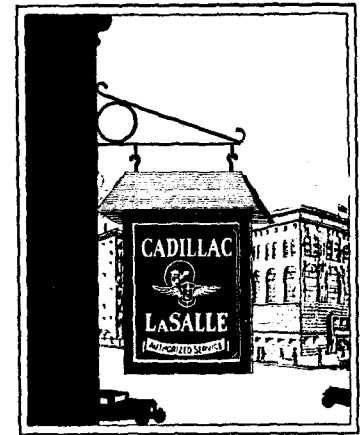

Fig. 1. Authorized Cadillac-LaSalle service stations display this sign at the service entrance.

The car owner's first and most frequent contact with Cadillac Service will naturally be in the service station of the

NO PAGE 4

distributor or dealer who sold him the car and who therefore has the greatest interest at stake in assuring his satisfaction. Nevertheless, he may feel perfectly free to use his car for extended travel without depriving himself of the service benefits to which he is entitled at his local service station. He will find other Authorized Cadillac-La Salle Service Stations able and willing to render the same service.

Service Card

As a means of introduction at other Authorized Cadillac-LaSalle Service Stations, every purchaser of a Cadillac car is given credentials in the form of a Service Card. This card is mailed to him by the Cadillac factory immediately after the delivery of the car is reported by the distributor or dealer. It is supplied in a celluloid case, and is intended to be carried in a holder on the car.

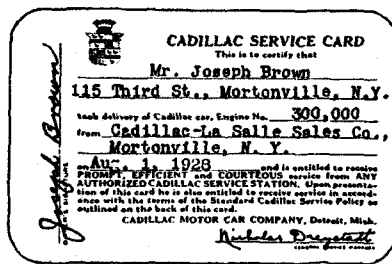

Fig. 2. The Service Card, when properly signed, identifies a Cadillac owner at any authorized Cadillac-La Salle service station.

Upon presentation of this Service Card to any Authorized Cadillac-La Salle Service Station, the car owner is entitled to uniform standard service in accordance with the Cadillac Owner Service Policy. This Policy is explained in detail in a certificate issued to each owner and mailed to him with his Service Card.

Briefly, it entitles the owner to:

1. All adjustments free of all charges that may be required within 90 days after the original delivery date (as shown on the card), provided the mileage of the car does not exceed 3000

and the adjustments are not made necessary by accident, abuse or neglect. This includes everything except lubrication, washing and storing.

2. Free replacement of any part which has proved to the Cadillac Motor Car Company's satisfaction to be defective in material or workmanship within one year after the delivery date, provided the mileage of the car does not exceed 12,000 and that the replacement was not made necessary by accident, abuse or neglect. This includes material and labor.

The Service Card is not transferable, and the no-charge service set forth above is effective only while the car is in the hands of its original owner.

Service Charges

Service work other than that described above is performed by Authorized Cadillac-La Salle Service Stations on a flat-rate basis. When a car enters the service station, it is promptly inspected by a tester, who then quotes the owner an exact price for the work he finds necessary. The owner authorizes the work at this price, and when he receives his bill, this is the price he pays.

Charges prevailing at Authorized Cadillac-LaSalle Service Stations are based on standard schedules furnished by the Cadillac Motor Car Company. These schedules call for methods and tools approved by the same engineers who designed and built the car, assuring the highest quality of work at the lowest possible price. Standard Price Schedules are open to inspection by owners at any Authorized Cadillac-La Salle Service Station.

Repair Parts

Genuine Cadillac parts, manufactured to the same rigid specifications as the parts entering into the original assembly of the car, are carried in stock by Authorized Cadillac-La Salle Service Stations. They are sold at uniform prices throughout

the United States, and are not subject to the addition of handling, excise or other supplementary charges. Printed price lists, published by the Cadillac Motor Car Company, are open to inspection by owners at any authorized Cadillac distributor's or dealer's establishment.

The Owner's Obligation

All of these service facilities are placed at the disposal of the Cadillac owner, in order that his car may be a continuous source of satisfaction and utility. This result cannot be guaranteed, however, unless the owner fulfills certain definite obligations himself, as follows:

1. To drive the car at moderate speeds for the first 500 miles.
2. To operate the car in accordance with the instructions contained in this manual.
3. To check the engine oil level every 100 to 150 miles, and add oil as often as necessary to keep the indicator at "full."
4. To check the tire pressure at least every week, and keep it up to the recommended pressure—45 pounds in front and 40 pounds in rear—on cars driven at high speeds, 50 pounds in front.
5. To add distilled water to the storage battery every 1000 miles, and in warm weather every 500 miles, or at least every two weeks.
6. To have the car lubricated every 1000 miles, or once a month, in accordance with the lubrication schedule on page 30.
7. To take the car to an Authorized Service Station for inspection every 1000 miles, or at least once a month.

Lubrication

The first five items above are details which do not necessarily warrant a visit to the service station. For lubrication, however, the owner is urged to patronize Authorized Cadillac-LaSalle

Service Stations, because they are prepared to furnish this service in a manner that cannot be duplicated elsewhere. Only approved lubricants are used, the specifications of which have been worked out by Cadillac engineers to give the best possible results. Workmen who specialize on Cadillac cars know exactly where lubrication points are located and how much lubricant to apply. The charge for this lubrication service is less than half a cent a mile, which includes the cost of the lubricants.

Inspection

Preventive service is a fundamental principle of Cadillac Service. "Preventive service" is the practice of inspecting the car at regular intervals and making those adjustments that need attention before the need becomes an emergency. Inspections should be made every 1000 miles, in order to insure transportation satisfaction. Authorized Cadillac-La Salle Service Stations will make such inspections without charge, provided no dismantling of units is necessary.

The Cadillac owner is urged to take full advantage of this, not only while the car is new, but throughout its entire life.

Preventive service rendered every 1,000 miles or once a month by an Authorized Cadillac-La Salle Service Station, is the surest guarantee of long life and complete motoring satisfaction at the least possible expense.

CHAPTER II

OPERATION

ONE of the first things the driver of a new car should do is to familiarize himself with the various controls described in the following chapter.

Locks

Each car is equipped with a hexagonal-handled key which is used to operate the combination ignition and transmission lock, the door lock and the tire carrier lock. In addition, cars that have rumble seats or package compartments fitted with locks have a separate key for these compartments. The compartment key has an oval handle.

The lock number is stamped on each key, but not upon the face of the lock. The owner should make a record of the key numbers as soon as he takes delivery of his car, so that in the event both keys are lost, a duplicate key can easily be obtained from a Cadillac distributor or dealer.

Ignition Switch Lock

The lock in the center of the instrument panel controls both the ignition switch and the transmission lock. When the key is turned, the cylinder of the lock will slide out about half an inch, turning on the ignition and unlocking the transmission by means of a cable connection to the shifter shafts. To shut off the ignition and lock the transmission, turn the key to the locked position and push the lock cylinder all the way in. The car can be locked when the transmission is in neutral or in reverse. Do not attempt to shut off the ignition when the transmission is in any forward gear. Be sure to **remove the key** before leaving the car.

Gasoline Gauge

The gasoline gauge, marked "Fuel," is the small dial on the extreme left. This gauge indicates in gallons the quantity of fuel in the tank at the rear of the car, and is operated electrically by current taken from the ignition circuit. To read from the gauge the quantity of fuel in the tank the ignition **must be switched on**.

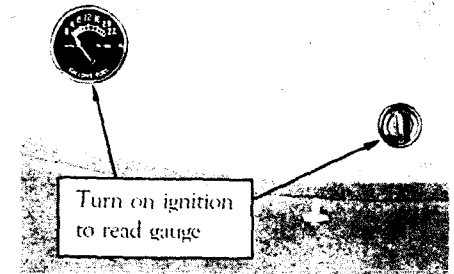

Fig. 3. The gasoline gauge is operated electrically by current from the ignition circuit.

Throttle Control

The throttle of the carburetor is controlled by a hand lever and a foot pedal or accelerator. The normal position of the hand lever for driving the car is all the way up (at "Close"). In this position the throttle of the carburetor is open just enough to permit the engine to run at idling speed after it is warm. For starting, however, the lever should be moved approximately one-fourth the way down, and should be left in this position until the engine is warm enough to permit the lever to be returned to the idling position without stalling the engine. (Also see Chapter on "Cold Weather Operation.")

Carburetor Choke Control

Correct use of the choke control not only is essential to quick starting of the engine, but also has an important effect on the life of the engine. The button must be pulled out far enough in starting to provide an explosive mixture quickly so that the battery is not unnecessarily discharged by useless cranking.

The button must also be left out far enough during the warming-up period so that the engine will run without missing and "popping back."

On the other hand, it should not be pulled out any further or left out any longer than is necessary to accomplish these results, because some of the excess liquid gasoline in the enriched mixture does not burn and washes off the oil on the cylinder walls, interfering with proper lubrication of the pistons. Push the button all the way in as soon as this can be done without causing "popping-back."

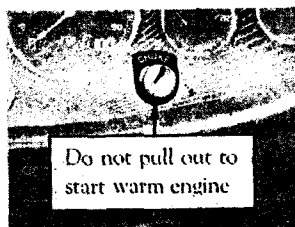

Fig. 4. The choke button must be held out while the starter is cranking the engine.

If the engine still retains heat from previous running, the choke control should not be used without first attempting to start the engine on the normal mixture. If the choke button is pulled out for starting a hot engine the mixture may be made so rich that starting will be impossible.

The choke button is not a priming device. It has no effect whatever on the fuel or the fuel mixture unless the engine is being cranked or is running under its own power. To have any effect, the button must be pulled out and kept partly out during the cranking operation.

Spark Control

Correct timing of the ignition in relation to the positions of the pistons is controlled automatically by the timer-distributor, which provides for all ordinary advancing and retarding of the spark.

A hand control is also provided. This is the button at the left on the instrument panel. This button should be pushed all the

way in (full advance) for starting and for all ordinary driving. The button can be pulled partly out to retard the spark in case of "ping" caused by carbon, heavy pulling, the use of regular (not anti-knock) gasoline, or in case there should ever be occasion to crank the engine by hand.

The Cadillac engine is a high compression engine and it will perform most satisfactorily when an anti-knock fuel is used. Regular gasoline can be used, although this may necessitate driving with the spark slightly retarded to avoid "ping." The spark should be retarded just to the point where the engine "pings" slightly on rapid acceleration. This slight amount of spark knock is absolutely harmless to the engine and is an indication to the driver that the spark is set at the point that will give maximum power and economy.

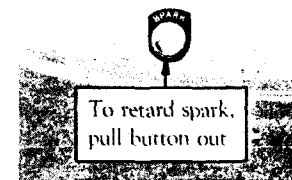

Fig. 5. Drive with spark control as far advanced as possible.

Carbon deposit, which accumulates with use in all engines, also causes spark knock and in time may require setting back the spark. Regardless of the kind of fuel or the presence of carbon, the correct setting of the spark control at any time is at the point where the engine "pings" slightly on rapid acceleration.

Starter Pedal

The starter pedal is at the right of the accelerator. Pushing this pedal forward brings into action the electric motor that cranks the engine for starting. Do not push the starter pedal when the engine is running.

The starter pedal is only one of the controls that must be manipulated to start the engine. Unless there is an explosive mixture in the cylinders and a spark to ignite it, it is useless to crank the engine. The starter pedal should not be operated,

therefore, until the necessary preliminary steps have been taken. The following, in their proper order, are the various steps that must be performed to start the engine:

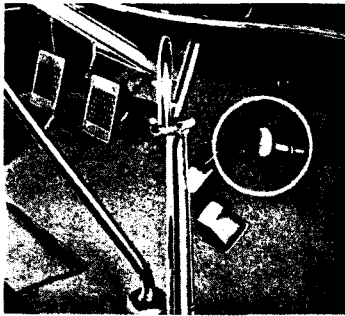

Fig. 6. The starter pedal is only one of the controls that must be used to start the engine.

5. Unless the engine is still warm, pull back the choke button. If the engine is still warm, do not pull back the choke button unless the engine fails to start on the normal mixture.

6. Push the starter pedal forward and hold it until the engine starts. Release it immediately as soon as the engine starts. (See below for probable causes for the engine failing to start.)

7. Push the choke button partly in as soon as the engine starts, and all the way in as soon as the engine is warm enough to permit it.

8. Note whether pressure is indicated on the oil pressure gauge and stop the engine at once if no pressure is indicated.

9. Move the throttle lever up to the idling position as soon as the engine is warm enough to permit it.

In cold weather, disengage the clutch before pressing down the starter pedal, and hold it down during the cranking operation. This relieves the starter of the necessity of turning the

1. Place the throttle lever about one-fourth the way down from the idling position.

2. See that the spark control button is all the way in.

3. Switch on the ignition.

4. Make sure that the transmission control lever is in neutral.

transmission gears, which are immersed in lubricant. The additional load is small in warm weather when the lubricant is thin, but in cold weather the power required to turn the gears through the thickened lubricant adds unnecessarily to the demand upon the battery.

What To Do If The Engine Fails To Start

If the engine fails to start after being cranked for a few seconds, release the starter pedal and investigate the following possible causes:

The ignition may be switched off.

There may be no gasoline in the tank in the rear of the car.

There may be no gasoline in the vacuum tank on the dash. If the fuel supply should give out on the road, so that the vacuum tank on the dash becomes empty, it will be necessary after refilling the tank to add gasoline to the vacuum tank.

The carburetor may be flooded by unnecessary use of the enriching device when the engine is warm. To get rid of this surplus gasoline in the carburetor open the throttle wide, and, with the ignition switched off, hold the starter pedal down for 10 to 15 seconds. Then return the throttle lever to the usual position for starting, switch on the ignition and try again to start the engine.

Oil Pressure Gauge

The small dial at the left of the clock is the oil pressure gauge. This gauge does *not* indicate the *quantity* of oil in the engine. It indicates only the *pressure* under which the oil is forced to the engine bearings.

When the engine is not running, the pointer on the oil pressure

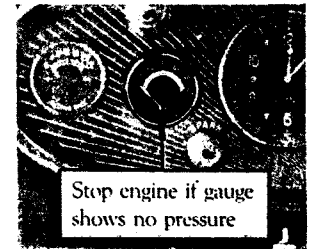

Fig. 7. The oil gauge does not indicate quantity; it only shows the pressure under which oil is forced to the engine bearings.

gauge should remain at zero, but as soon as the engine is started and as long as it runs, the gauge should show pressure. If the gauge does not show pressure when the engine is running, stop the engine at once and determine the cause. Serious damage may be done if the engine is run without oil pressure.

Ammeter

The ammeter should indicate on the "Charge" side most of the time. Otherwise, more current will be taken out of the battery than is put into it and the battery will eventually become fully discharged.

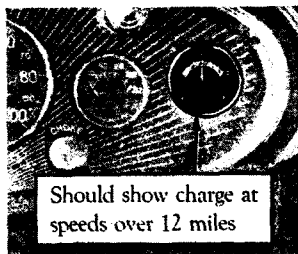

Fig. 8. The ammeter indicates the amount of electrical current flowing to or from the battery.

Ordinarily, when no lights are in use, the ammeter should show "Charge" as soon as the car is running ten or twelve miles per hour in high gear. If the ammeter should show "Discharge" with all lights off, either when the engine is not running or when the car is running more than twelve miles per hour, the cause should be investigated.

Clutch Pedal

The clutch has two uses: First, to enable the car to be started gradually and without jerk or jar; second, to permit shifting of the transmission gears. The operation of the clutch is discussed below in connection with the transmission control. Further comment is unnecessary at this point, except the following suggestions to the driver:

Do not drive with the foot resting on the clutch pedal. The Cadillac clutch operates so easily that even the weight of the driver's foot may unintentionally cause the clutch to slip.

Do not form the practice of disengaging the clutch whenever the brakes are applied. Most occasions for use of the brakes require only slowing down without stopping or even shifting gears. A skilled driver will not touch the clutch pedal until the car is just about to stop or until he is about to shift to a lower gear. It is a mistaken idea that applying the brakes with the clutch engaged is more severe on the brake lining. The opposite is actually the case, proof of which is in the fact that in coasting down grades, the resistance of the engine is used to assist the brakes in controlling the car speed.

It will be observed in operating the clutch pedal that the pedal offers almost no resistance until it has been moved about one inch. It is at this point that it actually begins to disengage the clutch. It is important that the pedal have this "lost motion." If the full pressure of the clutch springs is felt just as soon as the pedal is moved, the control rod should be readjusted. Failure to make this adjustment will result in the clutch slipping.

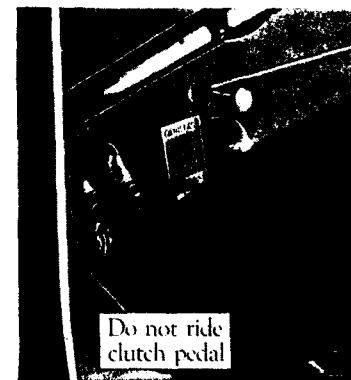

Fig. 9. A good driver uses the clutch pedal only when shifting gears or about to stop.

Transmission Control

The operation of the Cadillac Syncro-mesh transmission is, in general, the same as the operation of the conventional selective sliding-gear type of transmission. The positions of the control lever for the various speed combinations are the same and the directions in which the control lever is moved are the

same. It is also necessary to disengage the clutch before moving the control lever, the same as with the conventional transmission.

The only difference is in the manner of moving the control lever. With the conventional transmission, it is customary when shifting to a higher gear to hesitate momentarily in neutral and then move the lever quickly to its new position. With the Cadillac Syncro-mesh transmission there is no necessity either for the hesitation in neutral or for the rapid movement of the lever during the latter part of the shift. Instead, the movement of the control lever should be one smooth, continuous movement.

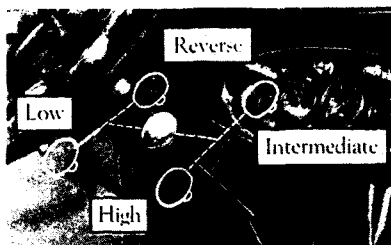

Fig. 10. The control lever positions are the same as for the conventional type of transmission.

The synchronizing principle applies to all shifts into intermediate or high; in other words, to the following shifts:

Low to intermediate
Intermediate to high
High to intermediate

There is no synchronizing mechanism for low or reverse gears because

shifts into these gears are usually made when the car is standing still. When shifting from neutral to low or reverse, therefore, it may be necessary to await an instant after disengaging the clutch, to give the gears a chance to stop "spinning." Do not attempt to shift from intermediate to low unless the car is standing still or moving very slowly.

If, when descending a grade at high speed, it becomes desirable to shift from high to intermediate in order to use the engine as a brake, re-engage the clutch slowly after making the shift. This will bring the engine up to speed gradually and avoid the sudden load that would otherwise be imposed upon the clutch.

Coasting

In coasting down grades, it is recommended that the transmission be left in gear and the clutch engaged. With the throttle in the idling position, the car is thus made to drive the engine, the resistance of which assists the brakes and saves wear on the brake lining. It must be remembered that the brakes are subjected to much more severe use on grades than on the level, because gravity acts continuously, whereas on the level, the brakes need absorb only the momentum of the car.

Ordinarily, the resistance offered by the engine when the transmission is in high is sufficient to control the speed of the car, supplemented by moderate use of the brakes. On steep grades, however, the transmission control should be shifted to intermediate.

Do not switch off the ignition when coasting with the car driving the engine. Contrary to a common impression, this does not appreciably increase the resistance, and is likely to cause damage to the engine. Even with the throttle closed, some fuel is admitted to the cylinders, and if this is not burned, it condenses on the cylinder walls and washes off the oil by which the pistons are lubricated.

Brakes

The foot brakes are internal brakes of the shoe type, applied on all four wheels through a mechanical linkage.

When applying the brakes on wet asphalt streets or slippery roads, do not disengage the clutch until the car is almost stopped. Do not attempt sudden stops. Cadillac four-wheel brakes minimize the possibility of skidding under these conditions, but their effectiveness should not induce anyone to drive less carefully.

As the brake lining wears, the pedal must be pushed farther down to apply the brakes. Do not wait until the pedal goes all the way to the floor board before having the brakes readjusted. Readjustment is recommended as soon as the pedal must be pushed down to within one inch of the floor board. A temporary adjustment of the brakes is explained on page 48.

For parking, the brakes are operated by the hand lever at the right of the transmission control lever.

Lighting Switch

The lighting switch control is at the upper end of the steering column in the center of the steering wheel. The lever has three positions besides the "off" position, which is the straight down position. Turning the lever to the left turns on the parking lamps on the fenders and the rear lamp. The first position of the lever when turned to the right switches on the headlamp lower beams and the rear lamp, while the second position to the right switches on the headlamp upper beams and the rear lamp.

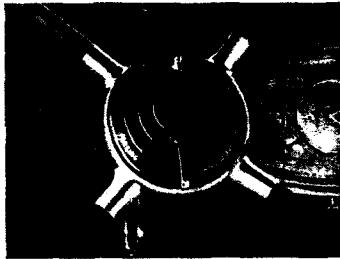

Fig. 11. The lighting switch control is at the hub of the steering wheel.

The instrument lamps are controlled by a separate

switch button at the extreme left of the instrument panel.

The lamp bulbs that are used are as follows:

Lamp	Voltage	Candle-Power
Headlamps	6-8	21 (Two Filament) Mazda No. 110
Stop lamps	6-8	15
Parking lamps	6-8	3
Instrument lamps	6-8	
Rear lamps	6-8	
Closed car lamps	6-8	

Danger of Running Engine in Closed Garage

Every person having to do with the operation or care of a motor car should be warned of the danger that attends running the engine while the car is in a small closed garage.

Carbon monoxide, a deadly poisonous gas, is present in the exhaust of all internal combustion engines. Most people are already familiar with carbon monoxide in the form of illuminating gas, or in the gas produced by furnaces and stoves when insufficient air is supplied to give complete combustion. But illuminating gas and coal gas have an unpleasant odor, which serves as a warning, whereas carbon monoxide, as produced in the internal combustion engine, is colorless, tasteless and almost odorless, so that the victim may be overcome before he is aware of the danger. When the engine exhausts into the open air, the carbon monoxide is so diluted that it has no effect. It is when the engine is run for a time in a closed room that the proportion of carbon monoxide in the air may increase to the point at which continued breathing of it would be fatal. The United States Public Health Service advises that the average automobile engine warming up in a single car garage will give off enough carbon monoxide in three minutes to endanger life.

Proper precaution must be taken in cold weather when the natural tendency is to keep the garage doors and windows closed. The practice of letting the engine warm up in a closed garage before opening the doors is unsafe. The risk is made greater by the fact that the enriching of the mixture by manipulation of the carburetor choke increases the amount of carbon monoxide formed.

CHAPTER III

EQUIPMENT

IN addition to the controls and instruments used in driving, the car is equipped with various devices which are for the convenience and comfort of the occupants, and are used only as occasion demands. It is suggested that the driver anticipate his use of such equipment by becoming familiar at once with the directions contained in this chapter.

Windshield and Ventilation

Cadillac closed cars are equipped with a one-piece slanting windshield that can be moved up and down by means of the handle just above the windshield (Fig. 12). For ventilation under the cowl, the windshield should be raised not more than

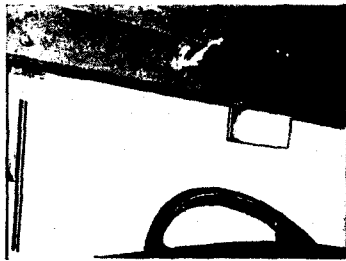

Fig. 12. The straight type windshield is controlled by the handle above the windshield.

one inch, so that the lower edge of the glass is still below the ledge over the instrument board. With the windshield in this position air is deflected into the driving compartment through an opening in the cowl just forward of the instrument board. If desired, the windshield can be raised above the level of the ledge over the instru-

ment board, and air will then enter directly into the car.

Cowl ventilators are also provided on the closed cars to supplement the ventilation provided by the windshield. These venti-

lators are at the sides of the cowl compartment and open toward the rear, serving as outlets for the air entering under the windshield.

In warm weather, satisfactory ventilation in the front compartment cannot be expected unless the hood doors are open. Ordinarily, these should be opened at the beginning of warm weather and left open for the season. The temperature in the front compartment can thereafter be controlled by the windshield and ventilators.

Windshield Cleaner

The windshield cleaner consists of two wiper blades, operated by the suction or vacuum in the passages between the carburetor and the engine. The cleaner is controlled by the lower button at the extreme left-hand end of the instrument board. This button has two positions. In the first position, both blades operate on the left side of the windshield; in the second position, the blades clean the entire windshield.

Adjustable Seat

The driver's seat is adjustable on all Cadillac closed cars, except those that are intended to be chauffeur-driven. Except on the five-passenger coupe, the entire front seat can be moved forward or backward. This adjustment is controlled by a handle on the center of the seat base, about three inches above the floorboards. To move the seat forward, turn the handle clockwise; to move it backward, counter-clockwise. The handle must be turned one-half turn at a time.

As the front seat on the five-passenger coupe is divided, only the driver's half of the seat is adjustable. The handle for making the adjustment is on the side of the seat, otherwise the adjustment is the same.

Cigar Lighter

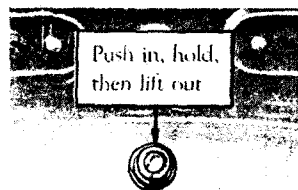

Fig. 13. The cigar lighter on the instrument panel is of the "pass around" type.

button beside the lighter.

Tools

The compartment for tools is under the front seat. When placing tools in the compartment be sure they are placed so that they do not interfere with the operation of the seat adjustment.

The tools comprising the standard equipment are listed below:

- | | |
|-------------------------------|---|
| 1. Hammer | 9. Pliers |
| 2. Monkey wrench | 10. Hub cap wrench |
| 3. Large screw-driver | 11. Brace wrench (wood and disc wheels) |
| 4. Small screw-driver | 12. Jack handle |
| 5. Crescent adjustable wrench | 13. Jack |
| 6. Oil can | 14. Tool bag |
| 7. Spark plug wrench | 15. Lubrication chart |
| 8. Starting crank | |
| 16. Operator's Manual | |

Tires

Inflation Pressure

For normal driving, the front tires should be inflated to a pressure of 45 lbs. and the rear tires to 40 lbs. The inflation pressure should be checked at least weekly, and should never be permitted to drop more than 5 lbs.

On cars driven at high speeds, the front tires should be inflated to 50 lbs. This is important.

Spare Wheel Carrier

To remove a spare wheel from the carrier, unlock the lock and take it out, using the key as a handle. It may be necessary to hold on to the lock while turning the key. Then unscrew the

clamping screw underneath the lock, after which the large dust shield can be removed and the wheel taken off the carrier.

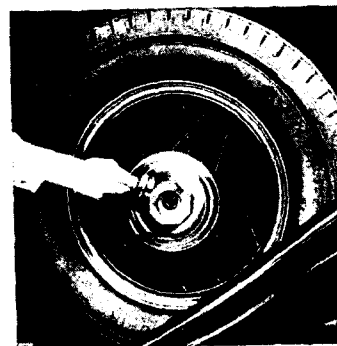

Fig. 14. To remove a spare wheel, unlock the lock, and remove the screw and the dummy hub cap.

To reinstall a spare wheel, mount it on the carrier, place the large dust shield in position and tighten the clamping screw. Then snap the lock back into place.

These instructions apply both to spare wheel carriers on the rear of the car and to carriers in the front fender.

Spare Tire Carrier (Standard Wood Wheels)

To remove the spare tire from the carrier, unlock the lock and remove it, using the key as a handle. It may be necessary to hold on to the lock while turning the key. Unscrew the clamping screw with the brace wrench furnished in the tool equipment and remove the rim clamp, taking care not to lose the clamping screw. Remove the tire with rim, by pulling it out at the bottom and then lifting it off the carrier.

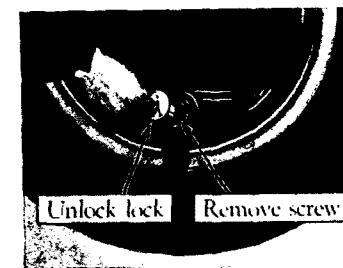

Fig. 15. To remove a spare tire, unlock the lock, remove the screw and take off the clamp.

To place a tire and rim on the carrier, reverse the above order. After tightening the clamping screw, unlock the lock and put it into place.

Use of Jack in Changing Tires

When a tire is "flat," the axle is not always far enough above the ground to permit placing the jack directly under the axle.

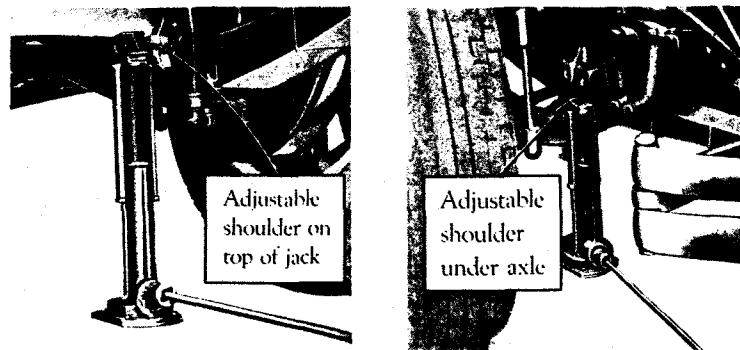

Fig. 16. The correct position of the jack for raising either front or rear wheels is shown above.

It is then necessary to make use of the adjustable shoulder which engages with teeth on the side of the jack.

The illustrations in Figure 16 show how the adjustable shoulder should be placed under the axles.

Changing Tires

If an inflated tire is always carried on the spare rim or wheel, the driver will seldom or never have to disassemble a tire from the rim. In case of tire trouble, it is then merely necessary to remove the rim or wheel with the flat tire and then install the spare in its place. Illustrated directions for performing this work on wire and on standard wood wheels are given on pages

28 and 29. Disc and demountable wood wheels are changed in the same manner as wire wheels except that the hub caps should not be removed.

Tire Balancing Marks

The tires are balanced to offset the weight of the valve stem. If a tire is removed, it must be re-installed in its original position with respect to the rim; otherwise the tire and wheel will be unbalanced.

A small red square is accordingly branded in the rubber on the side of each tire. This mark must always be in line with the valve stem.

Fig. 17a. Remove the hub cap with the wrench in the tool kit. Hub caps are marked with arrows showing the direction in which they screw on and off.

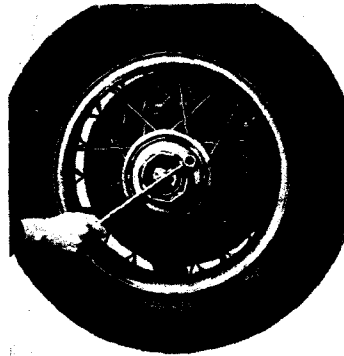

Fig. 17b. Jack up the axle until the weight of the car is off of the wheel, but with the tire still dragging. Loosen the cap screws around the wheel hub by turning them in a counter-clockwise direction with the wrench. Then jack the wheel up further, remove the cap screws and take the wheel off of the hub.

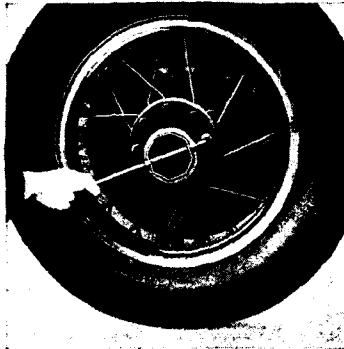

Fig. 17c. To mount a wheel simply set it up on the hub and start the cap screws by hand. Then tighten the screws with the wrench, but do not tighten them in rotation. After tightening one screw, tighten the screw directly opposite.

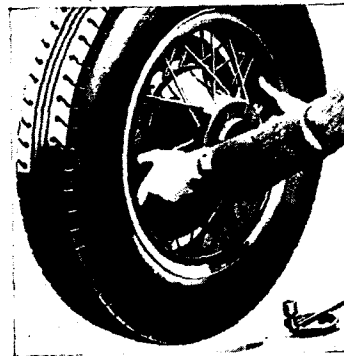

Fig. 17. Changing Wire Wheels

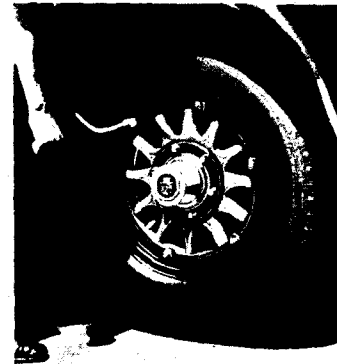

Fig. 18a. Jack up the wheel until the tire clears the ground. Remove the dust cap and clamping nut from the valve stem. Remove the six rim clamps, unscrewing them with the brace wrench supplied in the tool kit.

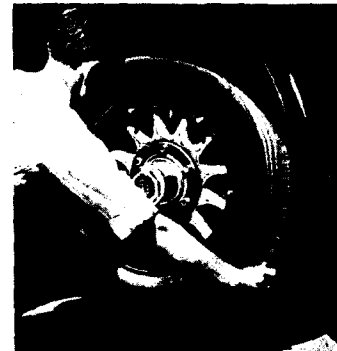

Fig. 18b. Rotate the wheel until the valve stem is at the top, and pull the bottom of the rim away from the wheel.

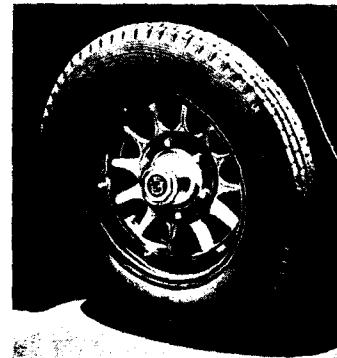

Fig. 18c. Then rotate the wheel until the valve stem approaches the bottom, when the rim and tire will roll free from the wheel and can be removed without lifting.

To mount a rim, rotate the wheel until the hole for the valve stem is in the position shown in the last illustration. Insert the valve stem and rotate the wheel, which will carry the rim with it, until the valve stem is at the top. Then push the lower part of the rim into place. Install the rim clamps over the rim and turn the nuts partly down. Go over the nuts again and tighten them firmly. Install the valve stem clamping nut and the dust cap. Be sure the clamping nut is tight.

Fig. 18. Changing Rims (Standard Wood Wheels)



LUBRICATION SCHEDULE

CADILLAC 355

OWNER'S NAME _____

ADDRESS _____

ENGINE NO. _____

DATE DELIVERED _____

DO NOT WAIT FOR SCHEDULE LUBRICATIONS BEFORE ADDING ENGINE OIL. THE OIL LEVEL SHOULD BE CHECKED EVERY 100 TO 150 MILES AND OIL ADDED IF THE INDICATOR BALL IS BELOW "FULL." THIS IS ESPECIALLY IMPORTANT ON CARS DRIVEN AT HIGH SPEEDS.

LUBRICANT	LUBRICATION NO. AND MILEAGE AT WHICH DUE											
	1	2	3	4	5	6	7	8	9	10	11	12
ADD LIQUID TO RADIATOR	WATER OR ANTI-FREEZE	○	○	○	○	○	○	○	○	○	○	○
ADD ENGINE OIL AS NECESSARY	ENGINE OIL	○	○	○	○	○	○	○	○	○	○	○
STARTER, GENERATOR AND DISTRIBUTOR OIL CLIPS	ENGINE OIL	○	○	○	○	○	○	○	○	○	○	○
BRAKE PINS AND CONNECTIONS	ENGINE OIL	○	○	○	○	○	○	○	○	○	○	○
DOOR HARDWARE	ENGINE OIL	○	○	○	○	○	○	○	○	○	○	○
GREASE GUN CONNECTIONS	CHASSIS GREASE	○	○	○	○	○	○	○	○	○	○	○
WATER PUMP GREASE CUP	WATER PUMP GREASE	○	○	○	○	○	○	○	○	○	○	○
ADD WATER TO STORAGE BATTERY	DISTILLED WATER	○	○	○	○	○	○	○	○	○	○	○
CHECK TIRE INFLATION		○	○	○	○	○	○	○	○	○	○	○
DRAIN AND REPLACE ENGINE OIL	ENGINE OIL		○	○	○	○	○	○	○	○	○	○
CLUTCH RELEASE BEARING	WHEEL BEARING GREASE		○	○	○	○	○	○	○	○	○	○
TRANSMISSION—ADD LUBRICANT	GEAR LUBRICANT			○	○	○	○	○	○	○	○	○
REAR AXLE—ADD LUBRICANT	GEAR LUBRICANT			○	○	○	○	○	○	○	○	○
STEERING GEAR—ADD LUBRICANT	GEAR LUBRICANT			○	○	○	○	○	○	○	○	○
TIMER DISTRIBUTOR CAM	LIGHT ENGINE OIL			○	○	○	○	○	○	○	○	○
FRONT BRAKE TRUNNIONS AND BRAKE CAM BEARINGS	CHASSIS GREASE					○	○	○	○	○	○	○
WHEEL BEARINGS	WHEEL BEARING GREASE					○	○	○	○	○	○	○
SPEEDOMETER DRIVE SHAFT	CHASSIS GREASE							○	○	○	○	○
**REFILL SHOCK ABSORBERS	SPECIAL OIL							○	○	○	○	○
**FLUSH COOLING SYSTEM								○	○	○	○	○
**REPLACE OIL FILTER CARTRIDGE AND CLEAN OIL PAN AND SCREEN												○

*IN SUMMER INSPECT BATTERY EVERY 500 MILES OR AT LEAST EVERY 2 WEEKS.
 **RECOMMENDED BUT NOT INCLUDED IN LUBRICATIONS 6 AND 12.
 THE FOLLOWING OPERATIONS CANNOT BE PLACED ON A MILEAGE BASIS AND ARE NOT INCLUDED IN THE ABOVE SCHEDULE.
 THIN REAR AXLE AND TRANSMISSION LUBRICANT—AS REQUIRED FOR LOW TEMPERATURES.
 DRAIN AND REPLACE REAR AXLE AND TRANSMISSION LUBRICANT—AT BEGINNING OF MILD WEATHER IN SPRING

RECORD ON OTHER SIDE

Fig. 19. This is a fac-simile of the Cadillac Lubrication Schedule and Record Card. Provision is made on the back of the card for recording when and where the car is lubricated. A copy of this card can be obtained on request from Cadillac distributors and dealers.

CHAPTER IV

LUBRICATION

Lubrication Schedule

SYSTEMATIC lubrication, at regular mileage intervals, is the only kind that is effective. On page 32 is a complete lubrication schedule, which, if faithfully followed, will insure correct lubrication for each wearing surface.

The unit of the schedule is 12000 miles, which is divided into twelve 1000-mile intervals. Corresponding to these is a series of twelve consecutive groups of lubricating operations. When the car has traveled 1000 miles, the points enumerated under Lubrication No. 1 should receive attention. At 2000 miles, Lubrication No. 2 is due, and so on until at 12000 miles, Lubrication No. 12 should be performed. At 13000 miles, the schedule begins again with Lubrication No. 1.

It will be noticed from the schedule that there are actually only four different lubrication operations, but that they are numbered according to the various times they they come due.

Although this schedule is expressed in terms of miles, it is intended that the car be lubricated once each month if the mileage traveled is less than 1000 since the last lubrication operation was performed. This lubrication work can be done while the car is in the service station for its regular monthly or 1000-mile inspection.

Cadillac distributors and dealers are prepared to sell lubrication based on this schedule. A car that is being lubricated on the schedule can be taken to any authorized Cadillac-La Salle service station, and without further ordering than to specify "Schedule Lubrication," the car will receive the necessary attention.

Lubrication Chart

The lubrication chart (18 x 24 inches in size) which accompanies this manual gives complete detailed instructions for lubricating the car. All of the points which require lubrication are designated on this chart, together with the kind of lubricant to be used, the method of applying it and the frequency with which it should be applied.

The operations are grouped on the chart in the same manner as on the schedule shown in Fig. 19. If the car is lubricated at an "Authorized Station," this schedule will be followed; if not, whoever does the lubrication should follow the schedule and chart exactly.

Lubricants

The selection of proper lubricants should be one of the first concerns of the owner in his attention to the lubrication of the car. The lubricants must not only be of high quality, but their viscosity and other characteristics must be suited to the car.

The owner is urged to consult the distributor or dealer from whom he purchased his car in regard to the names of lubricants which have been tested and approved for use in the Cadillac car.

Engine Oil

The chart of engine oil recommendations given on page 34 indicates the proper grades of oil to be used for average driving and for prolonged high speed driving.

Gear Lubricant

Lubricant conforming to the specifications for Gear Lubricant must be used in the transmission, rear axle and steering gear. It is particularly important that only recommended lubricants be used in the transmission. Oil or soap greases will *not* perform satisfactorily.

Lubricants conforming to these specifications may be used without thinning during all weather, except winter weather below temperatures of 20° above zero. Below this temperature, thinning with kerosene is necessary, in order to secure easier gear shifting and proper lubrication of gears and bearings.

ENGINE OIL RECOMMENDATIONS

TYPE OF SERVICE	SUMMER	WINTER	
	All Temperatures Above 32° F.	Between 32° and 15° Above Zero	Below 15° Above Zero
AVERAGE DRIVING (No prolonged high speed driving)	S. A. E. visc. 40 or 50	S. A. E. visc. 20	S. A. E. visc. 10
		<i>These oils are not suitable for prolonged high speed driving and if used under such conditions the oil level must be closely watched, as the rate of consumption will be higher than with heavier oils.</i>	
PROLONGED HIGH SPEED DRIVING	CADILLAC APPROVED "HEAVY DUTY" OILS— SUMMER AND WINTER These oils have an S. A. E. viscosity of 50-60, and are required to meet certain specifications as to volatility in order to demonstrate their fitness for prolonged high speed driving. To make certain of using an oil approved for this service, consult your Cadillac distributor or dealer. NOTE: Approved heavy duty oils vary in their suitability for winter use. If an approved heavy duty oil with sufficiently low cold viscosity is not available and if the car is not kept in a heated garage, the lighter oils specified above for average driving must be used to avoid hard starting. In this case, be sure to watch the oil level closely as cautioned above.		

*The system used in this table to designate body or viscosity is the one recently developed by the Society of Automotive Engineers and adopted by all oil companies. It takes the place of the old indefinite method of describing oils as "Light," "Medium," "Heavy," etc. Oil should be called for by these numbers. If a filling station attendant does not know the S. A. E. numbers of his oils, the following grades can be substituted in emergency: S. A. E. 10, Extra Light; S. A. E. 20, Light; S. A. E. 40, Heavy; S. A. E. 50-60, Extra Heavy.

Chassis Grease

Lubricant conforming to the specifications for Chassis Grease is recommended for all chassis points fitted with grease gun connections. Do not use ordinary cup grease, as such greases are not effective enough to lubricate satisfactorily over the 1000-mile interval.

Wheel Bearing Grease

Greases approved under the specifications for Wheel Bearing Grease are suitable for lubricating the wheel bearings and the clutch release bearing.

This grease is not recommended for chassis lubrication, as Chassis Grease is much more effective. Furthermore, Chassis Grease or ordinary cup grease should not be used in the wheel bearings as such lubricants do not have a sufficiently high melting point to render satisfactory service.

Water Pump Grease

A water-resistant calcium soap grease is recommended for use in the water pump grease cup. Only greases that meet the specifications for Water Pump Grease should be used; other greases will be dissolved into the cooling system liquid.

The owner of a Cadillac car is urged to have his car put on schedule lubrication at an authorized Cadillac-La Salle service station; in this way he is assured of having the proper lubricants used for all lubricating points at the proper mileage intervals.

Engine Lubrication

The supply of oil is carried in the cast aluminum oil pan that covers the bottom of the crankcase. The oil is circulated by a gear pump inside of the crankcase. The pump is driven by a vertical shaft, which is, in turn, driven by a spiral gear on the

camshaft. The oil circulated by the pump lubricates the main and connecting rod bearings, the camshaft bearings, the cylinder walls, pistons and piston pins, the front end chains, the valve mechanism and the fan.

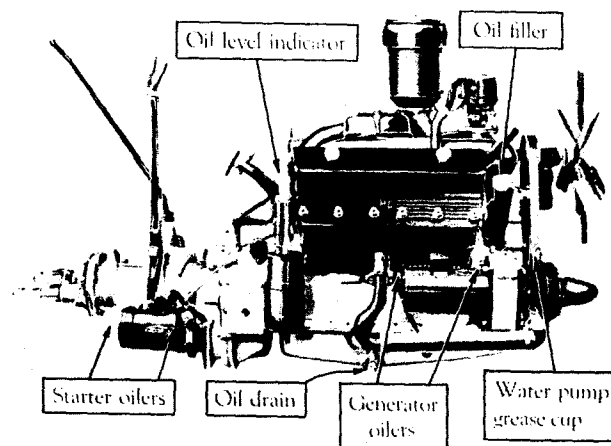

Fig. 26. Showing the location of the oil filler, oil level indicator, oil pan drain plug and other lubrication features.

There are a few points on the engine that are not taken care of in the pressure system. These are the starter, generator and distributor oil cups and the water pump. Lubricating instructions for these points are given in the lubrication chart.

Oil Level

The normal capacity of the oil pan is eight quarts, which fills it to the level of the screen in the pan. When the oil pan contains this amount, the oil level indicator on the right-hand side of the engine (Fig. 20) indicates "Full." As the oil level descends, the indicator indicates "Fill" and then "MT" (Empty). Oil should be added as soon as the indicator ball has dropped to

"Fill." If the indicator indicates "MT," under no circumstances should the engine be run until oil has been added.

The mileage interval at which oil must be added depends upon individual circumstances. It is recommended that the oil level indicator be checked every one hundred to one hundred and fifty miles, although it is improbable that oil will be required as frequently as this.

Crankcase Ventilating System and Oil Filter

Cadillac engines are equipped with a crankcase ventilating system, which prevents contamination of the lubricating oil from seepage vapors; and an oil filter, which removes any dirt or solid matter from the oil.

The crankcase ventilating system is entirely automatic and functions throughout the life of the car without requiring any attention from the owner. The oil filter, however, gradually becomes filled with the solid matter taken from the oil until it becomes so clogged that it ceases to function. For this reason, it is necessary to replace the filter cartridge every 12,000 miles.

The oil pan and screen should be removed and cleaned with kerosene or gasoline whenever the oil filter cartridge is replaced.

It is important that the filter cartridge be replaced just as soon as the 12,000 miles are up. Otherwise the whole purpose of the oil filter is defeated, and wear of the engine parts will result from the dirty oil. Filter cartridges for replacement can be obtained from Cadillac distributors and dealers, or from United Motors Service stations.

Replacing Engine Oil

Although the crankcase ventilating system and the oil filter described in the preceding section greatly prolong the useful life

of the oil, it is recommended that the oil be drained and replaced with fresh oil every 2000 miles.

To drain the oil, simply remove the drain plug (Fig. 20). Be sure to reinstall the drain plug before adding the fresh oil. Two gallons of fresh oil should be added, or enough to bring the oil level indicator ball to "Full."

CHAPTER V

COLD WEATHER OPERATION

SATISFACTORY operation of the car in freezing weather depends upon having the car prepared for cold weather and in giving it the special attention which is required at that time. In this chapter has been grouped all the information relating to care and operation of the car during cold weather. It should be reviewed just prior to the beginning of the winter season.

Preparing for Cold Weather

Anti-Freezing Solutions

The available commercial materials for preparing anti-freezing solutions for automobile radiators are denatured alcohol, distilled glycerine, and ethylene glycol.

Denatured alcohol solutions are, at present, the most generally used anti-freezing solutions. Denatured alcohol is widely distributed, affords protection against freezing, and is not injurious to the materials used in the cooling system.

There are two principal objections to denatured alcohol. Alcohol is lost by evaporation, especially on heavy runs, and unless the solution is tested periodically and sufficient alcohol added to replace the loss by evaporation, the engine or radiator, or both, are likely to be damaged by freezing.

The car finish is damaged by contact with the alcohol solution or vapors from the solution. Any alcohol accidentally spilled on the finish should be flushed off immediately with a large quantity of water.

The following table gives the freezing temperature and specific gravity of solutions of denatured alcohol and water:

Lowest Temperature Expected	Per cent by Volume	Specific Gravity (at 60° F.)	Qts. Alcohol required to make 6 gals. solution
10° F.	30	.9668	7 $\frac{1}{4}$
0° F.	38	.9567	9 $\frac{1}{4}$
-10° F.	45	.9475	10 $\frac{3}{4}$
-20° F.	51	.9350	12
-30° F.	57	.9260	13 $\frac{3}{4}$

Distilled glycerine and ethylene glycol solutions are, in first cost, more expensive than alcohol, but as they are not lost by evaporation, only water need be added to replace evaporation losses, except that any solution lost mechanically, by leakage foaming, etc., must be replaced by additional new anti-freezing solution. These solutions under ordinary conditions are not injurious to the car finish.

The principal objections to glycerine and ethylene glycol are the tendency of these solutions to loosen the scale and iron rust which forms in the water passages of the cylinder block and head, and the difficulty of securing and maintaining tight, leakproof connections. It is absolutely necessary to thoroughly clean and flush the entire cooling system before glycerine or ethylene glycol is used.

It is also necessary to tighten or replace the cylinder head gaskets and pump packing. The cylinder head gaskets must be kept tight to prevent the solution from leaking into the crankcase where it might cause gumming and sticking of the moving parts. The pump packing must be kept tight to prevent air from being drawn into the cooling system in order to avoid foaming and other difficulties which may result when air is present.

Glycerine or ethylene glycol should be used in accordance with the instructions and in the proportions recommended by the anti-freeze manufacturer.

In using a hydrometer to determine the temperature at which a solution will freeze, the test must be made at the temperature at which the hydrometer is calibrated. If the solution is warmer or colder, it must be brought to this temperature or correction must be made for the difference in temperature, otherwise large errors may result. In some cases these errors may be as large as 30 degrees Fahrenheit.

Salt solutions, such as calcium or magnesium chloride, sodium silicate, etc., honey, glucose and sugar solutions and oils are not satisfactory for use in automobile radiators.

Capacity of Cooling System

The capacity of the cooling system is six gallons when filled to the proper level. It is not necessary to add liquid to the radiator whenever the level falls below the filler. There is sufficient liquid in the cooling system if the upper tank is half-full, and any liquid in excess of this is usually forced out through the overflow pipe as soon as the engine becomes warm. When water is used, any loss from this cause is of little consequence, but in winter to conserve anti-freeze, it is important to avoid adding more liquid than is necessary.

Winter Lubrication

Lubrication of the car requires special attention in winter, not only to insure proper lubrication of the moving parts, but to secure the same ease of operation in starting, steering and shifting gears as during warm weather.

The chart of engine oil recommendations on page 33 gives the proper grade of oil to be used for cold weather driving. It will be noted that lighter oils can be used for cold weather providing no prolonged high speed driving is done. For prolonged high speed driving, "Heavy duty" oils must be used. Authorized Cadillac-La Salle Service Stations are prepared with full information on winter lubrication.

The lubricant in the transmission and rear axle should be thinned with kerosene as soon as the weather is so cold that the transmission gears are hard to shift. If a sufficient amount of kerosene is added to provide for the lowest winter temperature expected, it will not be necessary to add kerosene again thereafter during the winter. If ten per cent (a little over half a pint) kerosene is added, this will take care of temperatures down to ten below zero.

Storage Battery

The electrical system of an automobile has much more to do in winter than in summer. The engine is harder to crank and must usually be cranked longer before it starts. The lights are also used to much greater extent than during the long days of summer. All this means that the battery must be ready for increased demands.

It is therefore a good plan in preparing for the winter season to see that the battery is well charged to begin with, that the battery connections are clean and tight, and that the charging rate of the generator is sufficient.

Gasoline System

The carburetor on the Cadillac engine has automatic compensation for temperature. Nevertheless it is a good plan to have the carburetor adjustment checked when cold weather arrives. This inspection should give special attention to the carburetor choke control to make sure that the enriching device is fully effective when the choke button is operated.

In warm weather, a small amount of water in the gasoline has little or no effect on the running of the engine. In freezing weather, however, even a small amount of water may freeze and stop the entire flow of fuel to the carburetor. One of the things to be done in preparing for winter weather, therefore, is

to clean the gasoline filters and the sediment chambers in the gasoline system.

Starting the Engine

Choke Button

The first difference between starting the engine in cold weather and starting the engine in warm weather is in the greater use of the choke necessary in cold weather. Gasoline does not vaporize as readily at low temperatures, and in order to supply the cylinders with a gaseous mixture rich enough to be ignited, the proportion of liquid gasoline to air must be increased.

At the same time, it is important not to apply the choke more than is necessary. The unvaporized gasoline collects on the cylinder walls and works down past the pistons, washing off the lubricant as it goes. Although dilution of the oil supply with this unburned gasoline is minimized by the crankcase ventilating system, it is best to avoid an excess of liquid gasoline in the combustion chambers by careful and judicious use of the choke.

The following rule should govern the use of the choke in winter weather: Pull the choke back just as far as it is necessary to start the engine, but as soon as the engine starts, return the button as far as possible without causing the engine to stop or slow down. Then push the button all the way in as soon as the engine is warm enough to permit doing so.

Priming the Carburetor

In extremely cold weather, if the engine does not start after cranking for a few seconds with the choke button fully applied, release the starter pedal. Then prime the carburetor by opening and closing the throttle once or twice rather rapidly with the accelerator. Opening and closing the throttle operates a throttle pump on the carburetor and raises the level of the gasoline in

the carburetor. The carburetor should never be primed in warm weather and should not be primed unnecessarily in cold weather. Excessive priming is likely to make starting difficult rather than easy.

Position of Throttle Hand Lever

The correct position of the throttle hand lever for starting in cold weather is the same as for starting under other conditions, that is, about one-fourth the way down from the idling position. In warm weather, however, the lever may be returned to the idling position almost as soon as the engine is started. In cold weather the throttle must be left slightly open until the engine becomes warm.

Position of Spark Control

It is the practice of some drivers to move the spark control button all the way to "retard" whenever starting the engine. This is the correct position if the engine is to be cranked by hand, but if the engine is to be cranked with the starter, the spark button should be left in the fully advanced position.

Use of Starter

In extremely cold weather, when the car has been standing long enough to become thoroughly chilled, it is a good plan to disengage the clutch during the cranking operation. If this is not done, the starter is called upon to turn the jackshaft gears in the transmission in addition to cranking the engine. At ordinary temperatures, the additional energy required is negligible, but in extremely cold weather, the lubricant in the transmission offers sufficient resistance to rotation of the transmission gears to increase considerably the demand upon the battery and to retard the cranking speed.

Use of Accelerator Before Engine Is Warm

In cold weather, after the engine has been started and before it has run long enough to become warm, the engine cannot deliver its normal power, and it should not be called upon to do so. In accelerating the engine to start the car and in accelerating the car after the transmission is in gear, do not open the throttle suddenly or too far. To do so is not only to invite "popping back" in the carburetor, but to increase the amount of excess unvaporized gasoline in the combustion chambers, both of which results are undesirable.

CHAPTER VI

GENERAL CARE

No attempt has been made to include in this manual directions for making adjustments or repairs to the car. Most Cadillac owners prefer to depend for such work on authorized Cadillac-La Salle service stations, as these stations can invariably perform the work more conveniently and economically.

Every owner should, however, know how to perform the few simple operations of general care described in this chapter. These operations are not difficult enough to necessitate a visit to the service station, although this work can also be done in the service station, if desired.

Storage Battery

The storage battery is attached to the right-hand side bar of the frame under the front seat. It is accessible after removing the seat cushion and cover plate.

The battery is filled with an acid solution from which the water slowly evaporates, and fresh distilled water must be added to each of the three cells at regular intervals to bring the level up to the bottom of the filling tubes. Distilled water should be added at least every 1000 miles, and in warm weather, every 500 miles, or at least every two weeks. If distilled water is not available, melted artificial ice or rain water caught in an earthenware receptacle may be used. Hydrant water or water that has been in contact with metallic surfaces will cause trouble if used. Acid must never be added to the battery.

After adding water to the storage battery in freezing weather, the car should immediately be run far enough to mix the water and acid solution thoroughly. If the car is parked immediately after adding water, the water is likely to stay on top of the acid solution and may freeze, causing extensive damage.

As the storage battery is charged and discharged, the solution reacts chemically with the plates of the battery, the specific gravity of the solution changing as the reaction proceeds. The state of charge of the battery is thus indicated by the specific gravity of the solution. As the battery is charged, the specific gravity of the solution increases, reaching 1.270 to 1.285 when the battery is fully charged. The specific gravity of the solution decreases as the battery is discharged. A fully discharged battery has a specific gravity of 1.150 to 1.165.

A hydrometer is the instrument used to measure the specific gravity of a solution. A hydrometer syringe is a hydrometer especially designed for convenience in testing the specific gravity of the acid solution in the storage battery. A hydrometer syringe can be obtained at any battery service station. Be sure and get a reliable instrument, for cheap ones may be in error as much as 25 or 30 points.

The specific gravity of the acid solution should never be tested immediately after adding distilled water. If the solution is below the plates, so that it cannot be reached with the syringe, add the necessary amount of water, then drive the car for a few hours before taking the hydrometer reading.

The battery is a Delco battery, made by the Delco-Remy Corporation, Anderson, Indiana. If the storage battery is in need of attention other than recharging, it should always be taken to an authorized Cadillac service station or to a United Motors service station.

Cooling System

The cooling system should be kept filled with 6 gallons of water, except in freezing weather, when a suitable anti-freezing solution, such as those described on page 38, must be used.

The drain valve for the cooling system is in the water inlet elbow on the right side of the crankcase just in back of the generator.

The cooling system should be drained and flushed every 6000 miles. If possible, this should be done at a Cadillac service station, or where there are facilities for reversing the flow of water through the radiator. If this is not possible, use the following method:

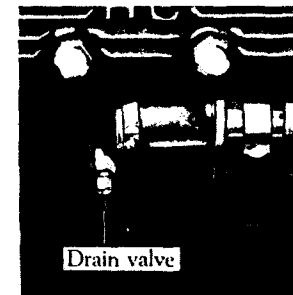

Fig. 21. The entire cooling system can be drained by opening this one valve.

Run the engine until the opening of the radiator shutters indicates that the engine is warm. Stop the engine and immediately open the drain valve.

After the liquid has drained off, refill the cooling system with hot water and repeat the operation described above. If, in draining the second time, the water is very dirty, it may be advisable to repeat the flushing operation a third time, placing one or two handfuls of sal-soda in through the radiator filler. The sal-soda must not be permitted to get on the finish of the hood or radiator. If sal-soda is used, the cooling system must be drained and flushed again before refilling for use.

Gasoline Filter

A gasoline filter (Fig. 22) is provided in the gasoline line between the vacuum tank and the carburetor. The filter has a

glass bowl through which the accumulation of water and sediment can be easily seen. The bowl should be removed and the gauze screen should be cleaned as soon as any accumulation appears in the bowl. This can be done as follows:

First shut off the gasoline by turning clockwise the small T-handle valve at the side of the filter. Then unscrew the thumb screw under the bowl, after which the yoke supporting the bowl can be swung to one side and the bowl can be removed. If the screen does not come off with the bowl, it can be removed by pulling it straight down.

In putting back the bowl, make sure that it seats properly against the cork gasket in the top of the filter before tightening the thumb screw. Do not forget to turn the gasoline on by turning the valve counter-clockwise as far as it will go.

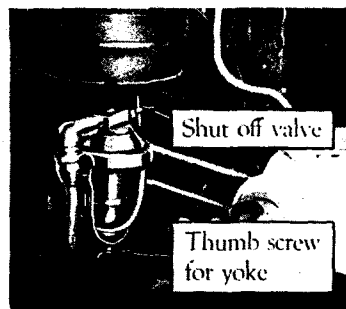

Fig. 22. The two gasoline filters should be removed and cleansed regularly.

There is also a strainer in the vacuum tank at the point where the gasoline enters the inner chamber. This strainer should be removed and cleaned occasionally. It is accessible after disconnecting the feed pipe and unscrewing the inlet elbow.

Temporary Brake Adjustment

It is recommended that all adjustment of the brakes be done at an authorized Cadillac-La Salle service station. In an emergency, however, the following temporary adjustment can be made by the driver.

Each brake is fitted with an adjusting nut on the cam lever, as shown in Fig. 23. To tighten the brake adjustment turn all

four adjusting nuts half a turn clockwise. These adjusting nuts lock each sixth of a turn.



Fig. 23. A temporary brake adjustment can be secured by turning the adjusting nut on each brake clockwise one-half turn. The front brake is shown above at the left, the rear brake at the right.

Body

Care of Finish

The lacquer finish of Cadillac bodies can be kept new and lustrous with the simplest care. The car should merely be wiped off every few days with a soft dry cloth. An occasional polishing with some recognized lacquer polish (for sale by all Cadillac distributors and dealers) will prove beneficial.

If the finish is cared for by being wiped at regular intervals, it will not need to be washed, except when it has accumulated a considerable amount of mud or dust. When washing the car, use plenty of clean cold water. Do not use hot water, and do not wash the hood while it is hot, as this will in time destroy the luster. Do not use soap.

If a hose is used in washing, do not use a nozzle, but let the water flow gently from the hose and flush off the dirt gradually. A soft wool sponge can be used to advantage in removing dirt.

After the washing is completed, squeeze the sponge as dry as possible and pick up all water from crevices. Then thoroughly

wet a clean soft chamois, wring it as dry as possible and dry the finish. The finish can then be rubbed with a clean soft cloth to bring out the luster.

Care of the Top

Ordinary dust can be removed from the top with a soft dry cloth. Grease spots, stains and dirt film can be removed by washing with a mild, neutral soap. Rinse thoroughly with clear water to remove all traces of the soap, then dry with a chamois or cloth. Gasoline, naphtha, kerosene and fabric cleaners should not be used for cleaning the top, as such preparations are likely to dull the luster and damage the fabric, causing leaks.

Cleaning Upholstery

To keep the upholstery in closed cars in the best condition, it should be cleaned thoroughly at least once a month with a whisk broom and vacuum cleaner. Dirt and grit accumulating in the fabric wear it out faster than use.

Spots on the upholstery may be cleaned with any good dry cleaner. When the cleaner has thoroughly evaporated, apply a hot flatiron wrapped in a wet cloth. Steaming the fabric and rubbing lightly against the nap will raise the nap on plush fabrics to its normal position.

Door Hardware

Many owners who give careful attention to lubrication of the chassis do not give the same attention to the lubrication of door locks and hinges. If the door hardware is to operate properly, it must be lubricated regularly. Directions for this lubrication are included in the lubrication chart, and these directions should be followed as faithfully as the rest of the chart.

CHAPTER VII

STORING CAR

IF THE car is not to be used for a period of several months, it should be protected from deterioration during the period when it is not in use by carefully preparing it for storage.

Engine

To prepare the engine for storage, proceed as follows: Run the engine until opening of the radiator shutters indicates that the engine is warm. This may be done by driving on the road or by running the engine idle. In the latter case, care should be taken that there is sufficient ventilation to avoid injury from carbon monoxide poisoning. (See page 21). After the engine is warm, place the car where it is to be stored and stop the engine.

Remove the spark plugs. Inject two or three tablespoonfuls of engine oil into each spark plug hole, and before replacing the plugs, crank the engine three or four revolutions with the ignition switched off. This will tend to distribute the oil over the cylinder walls. The engine should not be started again after injecting the oil. If it is started, it will be necessary to repeat the treatment.

Drain the cooling system.

Storage Battery

If the car is to be stored during the winter, the storage battery should have special treatment in order to protect it against freezing.

Shortly before the car is used for the last time, distilled water should be added to bring the level of the solution up to the

bottom of the filling tubes. (See page 45.) After the water added has had an opportunity to mix thoroughly with the acid solution by running the car or engine, the specific gravity should be taken with a hydrometer. If the specific gravity of the solution is above 1.270, there will be no danger of the acid solution freezing. If, however, the specific gravity is below 1.270, the battery should be removed and charged. Unless the battery is fully charged, or nearly so, it is probable that the acid solution will freeze and cause extensive damage.

The battery ground connection should in all cases be disconnected during storage, as a slight leak in the wiring will discharge the battery and lower the specific gravity to the point where the solution may freeze.

If possible, the storage battery should be removed and charged from an outside source every two months during the storage period.

Tires

During the storage of the car, it is best to remove the tires from the rims and to keep the casings and tubes in a fairly warm atmosphere away from the light. The tubes should be inflated slightly after the tires have been removed.

If it is not convenient to remove the tires from the car, and the car is stored in a light place, cover the tires to protect them from strong light, which has a deteriorating effect on rubber.

The weight of the car should not be allowed to rest on tires during the storage period. If tires are not removed, the car should be blocked up, so that no weight is borne by the tires. The tires should also be partly deflated.

Body and Top

A cover should be placed over the entire car to protect it from dust. In storing an open car, the top should be up.

Taking Car out of Storage

In putting into use again a car that has been stored, it is advisable, unless the storage battery has been removed and charged at periodic intervals, to remove the battery from the car and give it a fifty-hour charge at a four-ampere rate. If the battery has received periodic charges, or if the specific gravity is above 1.200, simply add distilled water to the proper level and connect the leads. If there is a greenish deposit on the terminals of the battery, remove this with a solution of bicarbonate of soda (common cooking soda) and water. Do not allow any of this solution to get into the battery.

Before starting the engine, drain the oil from the oil pan and remove and clean the oil pan and screen. After reinstalling the oil pan, add eight quarts of fresh engine oil. Fill the cooling system, being sure to use anti-freezing solution in freezing weather. Remove the spark plugs and inject two or three tablespoonfuls of engine oil into each cylinder. Reinstall the spark plugs and, with the ignition switched off, crank the engine a few seconds with the starter to distribute the oil over the cylinder walls.

Start the engine in the usual manner. As soon as the engine starts, immediately let the choke button go as far forward as possible without causing the engine to stop or slow down materially, and then open the throttle until the ammeter reads approximately 10 with all lights switched off. While the engine is running, lift the aluminum cap on top of the carburetor and inject two or three tablespoonfuls of engine oil. It is a good plan to run the car outdoors as soon as this has been done. Release the choke button entirely as soon as the engine is warm enough to permit it.

CHAPTER VIII

SPECIFICATIONS AND LICENSE DATA

Type of engine.....	8 cyl. V-type
Diameter of cylinder bore.....	$3\frac{3}{8}$ in.
Length of stroke.....	$4\frac{15}{16}$ in.
Piston displacement.....	353 cu. in.
Horsepower (N. A. C. C. rating).....	36.45
Engine number.....	See below
Capacity of gasoline tank.....	21 gals.
Capacity of engine lubricating system.....	8 qts.
Capacity of cooling system.....	6 gals.
Capacity of transmission.....	3 qts.
Capacity of rear axle.....	3 qts.
Wheelbase.....	134 in.
Tires, standard wood wheels.....	6.50-19
Tires, demountable wheels.....	7.00-18
Spark plug setting.....	.025-.028 in.
Contact point setting.....	.018-.022 in.
Generator charging rate, maximum.....	{ 15-20 amps. cold 8-10 amps. hot

Engine and Unit Assembly Numbers

Each Cadillac car, when shipped, carries an engine number, which is also a serial number. This is the number to be used in filling out license and insurance applications and in general reference of the car. The engine number is stamped on the right hand side of the crankcase just below the water inlet.

The various units, such as the transmission, steering gear, etc., also carry unit assembly numbers. These are located as described below. It is important in ordering parts to give, not only the

engine number of the car, but also the unit assembly number of the unit to which the part belongs.

Transmission number—on the upper left-hand edge of the flange by which the transmission is bolted to the crankcase.

Steering gear number—on the steering gear housing next to the grease plug

Generator number—on the right-hand side of the generator.

Starting motor number—on the right-hand side of the starter, just below the switch.

Front axle number—on the upper surface of the right-hand spring pad, just outside of the car spring.

Rear axle number—on the rear surface of the axle housing just to the right of the cover plate.

Chassis (frame) number—on the flange of the first channel cross-member, next to the left front engine support.

INDEX

A	E
Accelerator.....11	Effect of Alcohol on finish.....38
Accelerator, use in cold weather.....44	Engine fails to start.....15
Adding water to battery.....46	Engine lubrication.....34
Adjustable seats.....23	Engine number.....54
Alcohol for anti-freeze.....38	Engine oil.....34
Ammeter.....16	Engine oil, changing.....36
Anti-freeze solutions.....38	Engine oil, thinning.....40
Authorized service stations.....5	Engine, preparing for storage.....51
	Engine, running in garage.....21
	Equipment.....22
B	F
Balancing marks on tires.....27	Filter for gasoline.....47
Battery.....45	Filter for oil.....36
Battery, preparing for storage.....51	Flat-rate service charges.....7
Brake adjustment.....48	Flooded carburetor.....15
Brakes.....19	Flushing cooling system.....47
	Foot brakes.....19
C	G
Cadillac service.....5	Gasoline filter.....47
Carbon monoxide poisoning.....21	Gasoline gauge.....11
Carburetor flooded.....15	Gasoline system, cold weather.....41
Carburetor, to prime.....42	Gear lubricant.....32
Card, service.....6	General care.....45
Changing engine oil.....36	Glycerine for anti-freeze.....38
Changing tires.....27	Greases.....32
Charging rate.....16, 53	
Charges for service.....7	H
Chart, lubrication.....32	Headlamps.....20
Chassis grease.....34	
Choke button.....11	I
Cigar lighters.....24	Ignition control.....12, 43
Clutch pedal.....16	Ignition switch lock.....10
Clutch, use of.....16	Inflation pressure.....24
Coasting.....19	Inspections.....9
Coincidental lock.....10	
Cold weather lubrication.....40	J
Cold weather operation.....38	Jack, use of.....26
Compartment for tools.....24	
Cooling system.....40, 47	K
Crankcase ventilating system.....36	Keys.....10
D	
Danger from carbon monoxide.....21	
Driver's seat adjustment.....23	
Driving speed when new.....8	

L	T
License data.....54	Specifications.....54
Lighting switch.....20	Specific gravity of battery.....46
Locks.....10	Starting the engine.....13
Locks for spare tires.....26	Starting the engine in cold weather.....42
Lubricants.....32	Storage battery.....41, 45
Lubrication.....8, 31	Storing car.....51
Lubrication, chart.....32	Syncro-mesh transmission.....17
Lubrication, cold weather.....40	
Lubrication, engine.....34	O
Lubrication, schedule.....31	Obligations of owner.....8
	Oil filter.....36
	Oil level.....35
	Oil pressure.....15
	Operation.....10, 38
	P
	Parts, uniform prices.....7
	Preventive service.....9
	Priming carburetor.....42
	R
	Repair parts.....7
	Replacing engine oil.....36
	Replacing filter cartridge.....36
	S
	Schedule lubrication.....31
	Seat adjustments.....23
	Service card.....6
	Service charges.....7
	Service stations.....5
	Shifting gears.....17
	Spare tire carriers.....25
	Spark control.....12, 43
	U
	Unit assembly numbers.....54
	Use of accelerator before engine is warm.....44
	Use of jack.....26
	V
	Ventilators.....22
	W
	Water pump grease.....34
	Wheel bearing grease.....34
	Windshield.....22
	Windshield cleaner.....23
	Winter lubrication.....40
	Winter operation.....38
	Wire wheel carrier.....25



LASALLE
Series 345-V-8
Color
Combinations

SEPTEMBER
OCTOBER
1930

CADILLAC MOTOR CAR COMPANY

OPTIONS

Color combinations 7, 13, 22, 27 and Black are optional on all La Salle Body styles.

Color combinations 8 and 12 are optional for open cars, Convertible Coupes, and 2-Passenger Coupes in addition to the five standard options.

Combination 7 and 8 when specified for stationary top models roof will be Black.

Standard extra charges apply to the colored fenders supplied with combinations 7 and 8 but on request Black fenders will be furnished without charge.

UPHOLSTERINGS

Closed Body Styles

3T131	Grey Mohair
5T131	Taupe Mohair
7T131	Taupe Broadcloth
16T131	Grey Whipcord <small>Optional—</small>
32T131	Taupe Whipcord <small>Convertible Coupe</small>
34T131	Blu-Grey Broadcloth <small>All Weather Phaeton</small>

Open and Convertible Body Styles

1T1331	Brown Leather
2T1331	Green Leather
3T1331	Black Leather
4T1331	Grey Leather

LASALLE



Combination 7

Lower Panels, Window Reveals—
Brummel Brown, Duco 2445912.
Rear Quarters, Upper Panels, Mouldings, Fenders, Chassis—Hazelwood Brown Light, Duco 2446067.
Strip—Tokio Ivory, Duco 2885757.



Combination 8

Lower Panels, Window Reveals, Rear Quarters—Scaraba Green, Duco 2445679.
Upper Panels, Mouldings, Fenders, Chassis—Arizona Grey, Duco 2446101.
Stripe—Pastel Cream, Duco 2883853.



Combination 12

Lower Panels, Window Reveals—
Sarasota Blue, R-M 20297.
Remainder Body—Black.
Stripe—Tokio Ivory, Duco 2885757.



Combination 13

Lower Panels, Window Reveals—
Cambray Green, R-M 20391.
Remainder Body—Black.
Stripe—Tokio Ivory, Duco 2885757.



Combination 22

Lower Panels, Window Reveals—
Afghan Maroon, Duco 2446172.
Remainder Body—Black.
Stripe—Eng. Verm., Duco 2884182.



Combination 27

Lower Panels, Window Reveals—
Jefferson Blue, Duco 2446125.
Remainder Body—Black.
Stripe—Avignon Blue, R-M 20267.

All Black; Stripe—Tokio Ivory 2885757.
Optional on all Body Styles.

PAGE 1.

In the following pages, we will describe the new cars of the Cadillac 353 and LaSalle 340 series, as presented at the Distributors' Convention.

The general specifications of the cars together with detailed equipment are listed.

The number assigned to each of the specifications corresponds with the number on the tag of each car and may be used for convenience in ordering duplicates of any of the jobs shown. Duplicates of non-production jobs will be available for September delivery.

DISTRIBUTORS CONVENTION

AUGUST 12 - 15th, 1929.

GENERAL INFORMATION COVERING

COMPLETE CADILLAC AND LASALLE LINES

While we wish to discuss the three distinct divisions, Cadillac, LaSalle and Fleetwood of our production in detail in the following pages, there are certain features applicable to the complete lines.

Wheels & Axle Ratios

The Cadillac line this year will have standard wood wheels, with the conventional carrier on the rear for the spare. The wheels will be 19" and the tire size 7.00-19. This year, we are offering a demountable wood wheel, finished in natural color in two styles, either carrying a single wheel on the rear, or with fender well equipment. When these demountable wood wheels are specified in the color of the car, they will have to be ordered as "special", otherwise, we shall consider orders specifying demountable wood wheels to be a natural finish. The wire and disc wheels will be finished, either with single carrier on the rear, or with fender wells. No provision has been made for production to furnish the carrier for two wheels on the rear. At a later date, it is possible that we shall be able to supply some sort of an adapter through the Parts Department.

The axle ratios available on Cadillac are standard 5.08-1. Unless otherwise specified, this will be used on all models, with the exception of Roadsters, Two Passenger Coupes and Convertible Two Passenger Coupe types, where the optional gear ratio of 4.75-1 is used. Under no consideration should 4.75-1 be specified on either the Five or Seven Passenger Sedan types.

The LaSalle line this year will have two sizes of wheels and tires. The standard wood, with the conventional type carrier, will be a 19" wheel and take a tire of 6.50-19. All other types of wheel equipment on LaSalle will be 18" and take tire 7.00-18. As in the past, only United States tires will be offered on the LaSalle line. As in the Cadillac, we are prepared to supply demountable wood wheels, with the spare on the rear as well as fender wells. Wire and disc will be available with the spare on the rear or two spares with fender wells. No provision has been made for the carrying of two spares on the rear. If we are able to offer a special adapter at later date on Cadillac, it will also be available for LaSalle.

The standard gear ratio will be 4.54-1 for all models, with the exception of the Seven Passenger Sedan and Seven Passenger Imperial, which we would recommend be equipped with 4.91-1. These axle ratios should apply almost universally with the exception of the few localities where there is considerable mountain travel, or added power required. For high speed work, we have released a 4.00-1 to be supplied only on the Roadster, Phaeton, Two Passenger Coupe and Convertible Coupe.

SPECIAL EQUIPMENT AND PAINT PRICES

We have been unable to revise our list of accessories, painting, and upholstery prices in sufficient time for this book. The same policies we have pursued in the last year regarding prices, will apply until such time as a new bulletin can be issued. The price list of cars will include the extra charges for wheel equipment.

**CADILLAC COLOR POLICIES
(Fisher Line)**

We shall release each month the color combinations to be used as standard production. The policy of allowing special colors on lower panels and window offsets with standard Black parts will be continued without extra charge. Where combinations are offered in production with painted fender sets the usual charge of fifty dollars list (\$50.00) will apply. On special orders with non production colors the extra charges of last year for such features as roof and rear quarters, upper panels, mouldings, fenders and chassis will be continued. To facilitate production and selling we have prepared a pamphlet containing color chips and a concise description of color distribution of all color combinations now standard.

Each color combination is numbered combination 1, 2, 3, etc. Therefore in ordering cars it will be satisfactory to specify the combination number as shown above the color combination.

The various body styles have been segregated into two groups, one group consisting of the Convertible 2-Passenger Coupe, standard 2-Passenger Coupe and Town Sedan will be known as Sport Type group. The second group or Conservative Type group comprises the five passenger coupe, five passenger sedan, seven passenger sedan and seven passenger Imperial sedan. Color combinations offered on the Sport Type group can be had on the Conservative Type group or vice versa, on order only.

As standard colors are changed a pamphlet containing a new lineup of all standard colors will be furnished gratis, to all distributors in limited quantities.

The color pamphlet will also contain color chips and concise description of color distribution of any special color combinations which may be offered from time to time.

Specifications received wherein the distributor specifies colors not guaranteed for durability by the manufacturer will be rejected. We will, however, accept such orders for shipment in primer finish thus enabling the distributor to arrange locally to finish the car in any nondurable colors for which he may receive orders.

When color combinations offered as standard are discontinued it is agreed the factory will fill orders for such colors under the conditions originally offered.

TRIMMING OPTIONS

These include 4 mohair materials of the highest quality, 1 Bedford cord cloth, and 3 bellflower patterned broadcloths with plain headlining, numbered as follows:

- 24 T 129 / Brown with darker brown bellflower pattern / broadcloth.
- 26 T 129 / Gray with blue bellflower pattern / broadcloth.
- 28 T 129 / Tan with green bellflower pattern / broadcloth.
- 50 T 128 / Gray / Bedford cord.
- 19 T 129 / Blue mohair.
- 51 T 128 / Silver gray mohair.
- 63 T 128 / Taupe mohair
- 67 T 128 / Green gray mohair

In addition to the choice of these trimmings, 2 passenger Convertible Coupes are furnished in four leathers options to be known as standard blue, standard tan, standard green, standard black, also 50 T 128 gray Bedford cord is offered optional in this body style.

Method of trimming is pleated and tufted. All door pockets are eliminated. Pleated and tufted method of trimming is also standard in the 2 passenger Convertible Coupe. Full width auxiliary seats are furnished in all 7 passenger body styles.

New upholstery samples will not be sent to the distributors as there have been no changes made. Samples distributors now have they may continue to use.

CLOSED BODY STYLES

General specifications of all closed body styles are as follows:

All body styles have the full front seat equipped with adjustable seat features. Adjustable seat feature in the 5-Passenger Coupe effects the driver's seat only. There is no adjustable seat feature in the Imperial 7-Passenger Sedan.

VANITY CASES

The 2-Passenger Coupe and Convertible 2-Passenger Coupe have an ash receiver in the right front door only. All other body styles have combination Pas-a-lite lighter and ash tray in one case, the lady's case containing ash tray, memo book, pencil and mirror.

While special leather can be furnished, subject to extra charge their use should be discouraged because of the generally unsatisfactory results obtained. It should be understood that the factory accepts no responsibility for any such leathers furnished, either for wearing qualities or fastness of color.

THE BOOK
OF
FLEETWOOD



*A handbook of Fleetwood
bodies for Cadillac and
LaSalle retail salesmen.*



1929-1930
CADILLAC MOTOR CAR COMPANY
DETROIT, MICHIGAN

Regular finish, upholstery, and equipment

ALL Fleetwood bodies are finished in Duco. Any color combination may be had at no extra charge. This is one of the strong sales appeals of Fleetwood.

In order that body styles may be kept in stock, certain color combinations have been selected as "stock" or regular. These are in the conservative shades which experience proves are most acceptable. These combinations will be used throughout the 1929-1930 season on the enclosed drive types and transformable types.

- 1—Duco Cromwell blue lower panels, hood, and window reveals.
Black upper panels and moulding.
Gold stripe.
- 2—Duco Mulberry maroon lower panels, hood, and window reveals.
Black upper panels and moulding.
Gold stripe.
- 3—Duco Alpinstock green lower panels, hood, and window reveals.
Black upper panels and moulding.
Cream stripe.
- 4—Duco Sable lower panels, hood, and window reveals.
Black upper panels and moulding.
Old ivory stripe.

All fenders and chassis black.

In addition, Fleetwood bodies in a variety of rich colors, lighter in shade, will be brought through periodically for stock. Bulletins will announce these.

Colors available on open types, All-Weather types, and Sedanette types will be announced periodically.

UPHOLSTERY

EIGHT rich exclusive Fleetwood Doeskin Suede broadcloths by Wiese in subdued colorings harmonizing with any exterior color.

Exclusive Fleetwood Wiese broadcloths:

- Weise 2969 - - - - - Green Gray
- Weise 2970 - - - - - Maroon Taupe
- Weise 2971 - - - - - Tan
- Weise 2972 - - - - - Silver Gray
- Weise 2973 - - - - - Blue Gray
- Weise 2994 - - - - - Tan Taupe
- Wiese 3288 - - - - - Dark Gray
- Wiese 3363 - - - - - Dark Taupe

Optional in all enclosed drive and transformable types.

Three special Venetian mohairs of short nap.

Exclusive Fleetwood Venetian mohairs:

- 108-T - - - - - Green
- 109-T - - - - - Gray
- 110-T - - - - - Taupe

Optional in all enclosed drive and transformable types.

The first two blend well with complementary body colors, Taupe, because of its neutral shade, going well with any color.

Fifteen special exclusive Fleetwood Aero leathers by Radel. These are lightweight, soft, pliable, and luxurious, four being specified for stock with the balance optional without extra charge, with a reasonable added time allowance.

Special Radel Aero leathers:

- 5885 - - - - - Silver Gray
- 451 - - - - - Pearl Gray
- 2646 - - - - - Blue Gray
- 5897 - - - - - Green Blue
- 68 - - - - - Blue (Standard)
- 6016 - - - - - Dark Blue
- 9205 - - - - - Deep Maroon
- 5875 - - - - - Rich Maroon
- 4339 - - - - - Green (Standard)

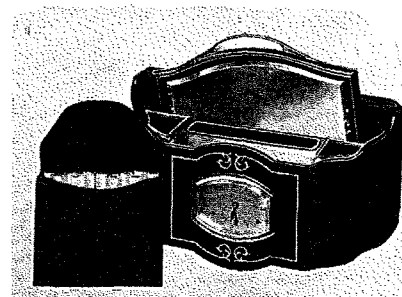

Vanity cases are designed exclusively for Fleetwood bodies and contain 8-day clock, mirror, leather cigarette case, and two ash receivers

6019	- - - - -	Soft Green
6012	- - - - -	Dark Green
9128	- - - - -	Light Brown
9131	- - - - -	Dark Brown
743	- - - - -	Tan (Standard)
2645	- - - - -	Black (Standard)

Optional in All-Weather Phaeton, Sedanette, and open types.

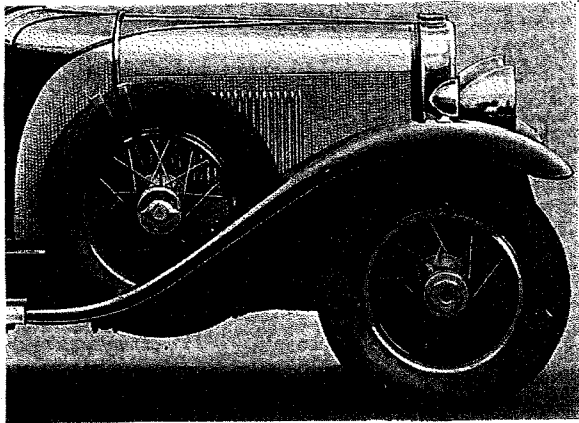

This picture shows a hood with damaskeen finish, a unique and attractive treatment

Six weatherproof Bedford cords by Wiese. The corded fabrics are used for seats with plain material to match for head linings. The waterproof feature of these materials makes them especially desirable for All-Weather types.

Special waterproof Wiese Bedford cords:

Wiese 2659-F, 2759-F	- - - - -	Green Gray
Wiese 2661-F, 2761-F	- - - - -	Brown Gray

Wiese 2662-F, 2762-F	- - - - -	Gray
Wiese 2663-F, 2763-F	- - - - -	Blue Gray
Wiese 2665-F, 2765-F	- - - - -	Maroon Taupe
Wiese 2666-F, 2766-F	- - - - -	Tan Taupe

Optional in All-Weather Phaeton and Sedanette types.

With the wide variety offered in the regular exclusive Fleetwood upholstery materials, we recommend that cloths be selected from Wiese collection No. 61 *only when absolutely necessary*, as there will be delays involved in securing curtains and other trimming materials to match. These delays are avoided in the case of the regular Fleetwood materials.

Enclosed drive types and transformable types.

Eight exclusive Fleetwood Wiese broadcloths—optional.

Three exclusive Venetian mohairs—optional.

Any material in current Wiese Collection No. 61—optional.

All-Weather and Sedanette types:

Fifteen Fleetwood Radel Aero leathers—optional.

Six weatherproof Fleetwood Wiese Bedford cords—optional.

Open types:

Fifteen Fleetwood Radel Aero leathers—optional.

(In the case of All-Weather Phaetons, Sedanettes, and open types, four of the exclusive Fleetwood Radel Aero leathers in the sample book will be specified for stock. The balance are optional with reasonable added time allowance.)

The distributing organization has already been furnished with samples of the three exclusive Fleetwood Venetian mohairs available. The distributing organization will be furnished with sample books of the eight exclusive Fleetwood Wiese doeskins, the six special weatherproof Wiese Bedford cords and the fifteen exclusive Fleetwood Radel Aero leathers as soon as such books are available.

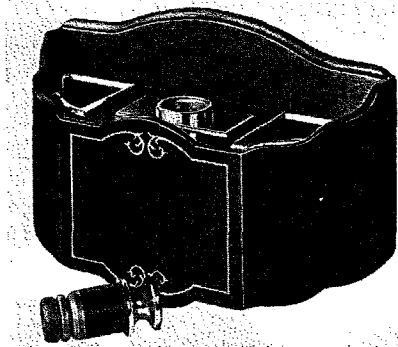

Smoker's set has inlaid case, with removable cordless lighter, and two ash receivers

EQUIPMENT

Equipment common to all body styles of each type (Sedans, Town Cabriolets, etc.) is found on pages 18 to 24. Equipment exclusive to each individual body style is listed on the page facing the illustration of that body style.

Wiring for radio installation is included in all body styles except 3902, 4002, 4060, 4057.

BODY STYLE OPTIONS

The four Town Car models—Fleetwick, Fleetmont, Fleetcrest, and Fleetbourne—can be had with collapsible rear quarters. Fleetwick, Fleetmont and Fleetcrest in stock, Fleetbourne to order.

Extra charges are:

Style 3912-C	- - - - -	\$750
Style 3920-C	- - - - -	800
Style 3925-C	- - - - -	750
Style 3991-C	- - - - -	800

The same feature can be had on all Sedans and Imperials for the following extra charges:

Style 3975-C	- - - - -	\$800
Style 3975-SC	- - - - -	800
Style 3930-SC	- - - - -	800
Style 3930-C	- - - - -	800
Style 3955-SC	- - - - -	750
Style 3955-C	- - - - -	750

Note: Prices apply *only before* metal has been built on wood frame. If collapsible rear quarter is wanted on body already "in metal," individual price quotation is necessary. Delivery time—4 weeks additional.

<i>Back windows</i> —Special size or shape	- - -	\$125
<i>Quarter windows</i> —Special size or shape	- - -	250
<i>Leather quarters</i> — <i>Sedans and Imperials</i> —Non-collapsible leather quarters with landau bows, quarter windows retained. Three weeks additional time	- - - - -	250

Without quarter window (3975 or 3975-S only) three weeks' additional time	- - \$300
Plain motor hood without raised panel (See page 86)	- 250
Sedanettes and Sedanette Cabriolet in special leather top material—Tan, grained to look like Burbank cloth	- - - - - 175
Opera seats—Instead of forward facing, in 3975, 3975-S, 3920, 3925, 3991	- - - - - 125
Concealed in 3912—lazyback omitted on left seat	- - - - - 200
In Five-Passenger Sedans	- - - - - 128

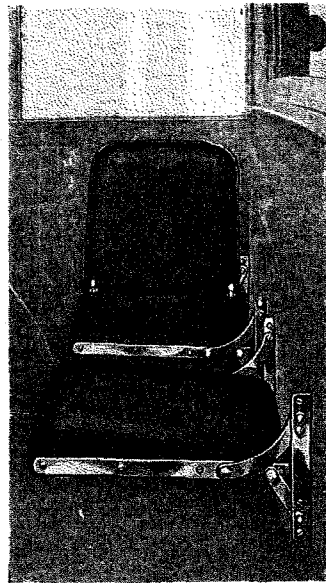

The Fleetwood "opera" seats, although designed for occasional use only, are remarkably comfortable. They are attached to the interior partition and fold up out of the way when not in use. As is shown, one seat faces the rear, the other with back, faces sideways. Seats are adjustable as to height

Sliding glass division—In Imperials and Town Cars with standard auxiliary seats	- - - \$150
With concealed auxiliary seats	- - - 250
More head room—Providing 52 1/2 inches	- - - 650
Roof baggage rail—(Roof strengthening; painted or chromium rail)	- - - 425
Omitting glass division with stationary Sedan front seat—All-Weather Phaetons	- - - 200
Glass division, Sedanettes and Sedanette Cabriolets—between front and rear compartments	- - 200
Transformable driver's roof solid—Permanent	- - 275
Detachable—with flexible extra roof curtain	350
Full flush glass division for 3975 (Same as standard in five-Passenger Imperials Styles 3930, 3955)	150
Wheels—Wood is standard. Regular extra charges on Fisher Body cars apply on Fleetwoods for any special wheel equipment.	

Note: Prices apply only on cars not yet built up at Fleetwood factories.

No credit or allowance on regular equipment omitted.

COLOR OPTIONS

Color book—The Fleetwood Company has issued a color book containing samples of suggested colors which can be specified for cars in addition to the four colors shown on page 101.

Upper and lower panels—Any color. (Includes striping.) No charge.

Fenders—Special colors at regular extra charges.

Colored leather quarters—For Cabriolets or Town Cars, Sedan and Imperial Cabriolet types; to match upper panels - - - - - No Charge

Damaskeen woods—Engine turned finish - - - \$265

Varnish—Seven weeks additional for varnish finish, all body styles. No guarantee - - - 250

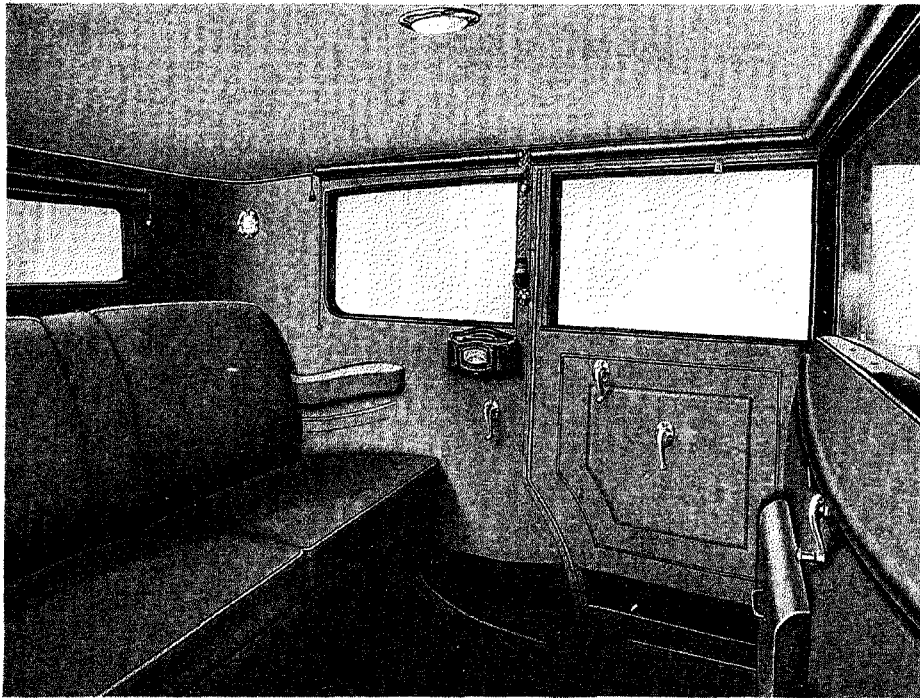

An interior view of one of the bodies. Note the general air of distinction, luxury, and roominess, the deep sprung seats with center and side arm rests upholstered in unobtrusive shades of broadcloth; also the side pockets and exclusive Fleetwood design of hardware

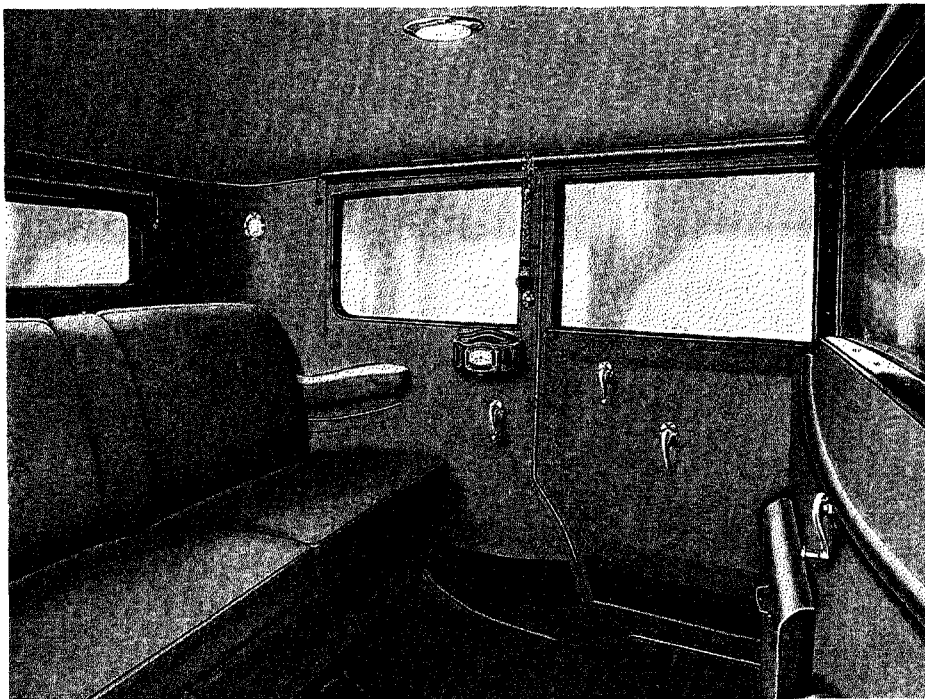

This picture shows one of the distinctive effects which may be achieved when a body is finished to individual requirements. In this case, the purchaser desired an outstanding and individual interior and specified Wiese broadcloth upholstery, embroidered in medallion effect with needlepoint work—the result being one of rare beauty

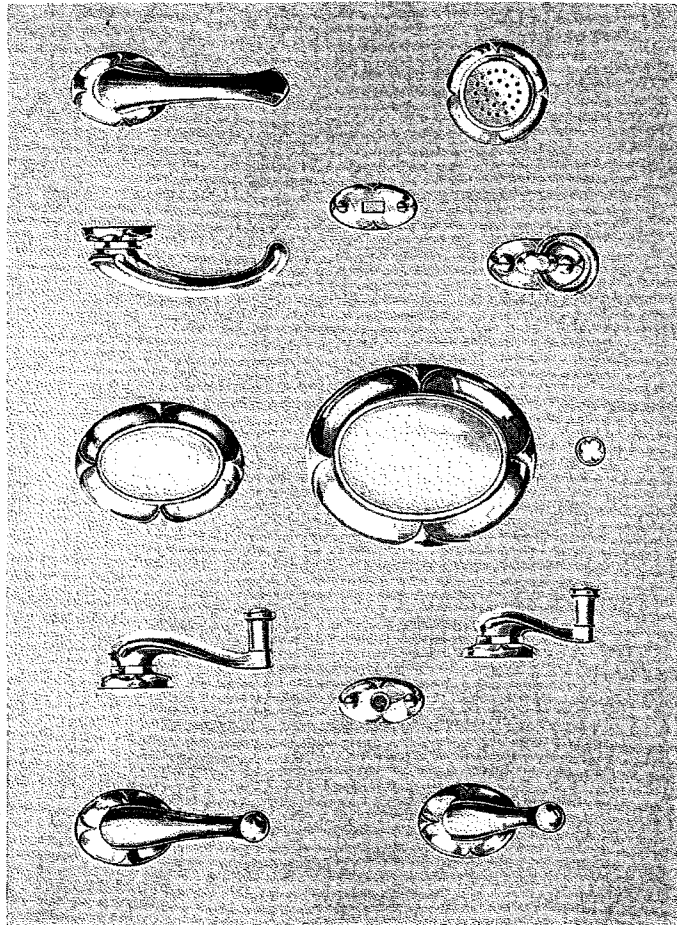

Hardware is created specially for the Fleetwood line, of beautiful design with chromium plated finish

UPHOLSTERY OPTIONS

See upholstery section, page 102.

Style—Tufted, pleated, etc., if ordered before body goes to Trim Department - - - - - No Charge

Special materials—Not included in Fleetwood broadcloths, mohairs, Bedford cords, Aero leathers or Wiese book, No. 61 - - - - - \$100

Needlepoint medallions, with broadlace on doors and divisions - - - - - 300

Leather—Transformables, Sedanettes, and enclosed drive types, front and rear cushions, balance broadcloth - - - - - No Charge

Seat cushions and up to belt - - - - - \$ 50

Entire interior, front and rear - - - - - 150

Colored, for All-Weather Phaetons, Sedanettes and open types (other than four standard colors) in Aero leather book, four weeks' additional time) - - - No Charge

Cushions—Any height, slope, or depth; provided orders are received before body goes into trim and standard seat box can be used - - - No Charge

Lap robes—Monogrammed, crushed plush backing - - - - - \$ 80 (Up)

Pockets—Flush type not possible. Envelope type attached on all doors - - - - - \$ 75

Down pillow—Not standard, if desired - - - 18

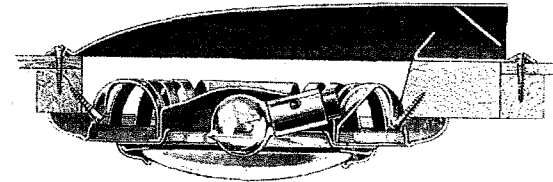

The handsome Fleetwood ventilating dome light not only illuminates the interior at night but ventilates the ceiling whenever the car is in motion

EQUIPMENT OPTIONS

<i>Foot rail</i> —Carpet-covered, to replace hassocks. (Must be ordered before body leaves factory) No charge	
<i>Mats</i> —Rubber for front compartment all types	- \$ 18
<i>Linoleum</i> —Metal bound, front floor boards, all types	- - - - - 32
<i>Extra carpet</i> —For rear or front compartment	- - 25
<i>Hardware</i> —Colored to match upholstery	- - 25
Other finishes	- - - - \$ 25 (Up)
Special design	- - - - On Quotation
<i>Vanity and smoking sets</i> —For All-Weather and Sedanette types, attached to division	
Vanity	- - - - - \$ 55
Smoking	- - - - - 26
Special finish	- - - - - On Quotation
<i>Inside moldings</i> —To match vanity cases in special finish	- - - - - \$ 35 (Up)
<i>Robe rails</i> —Bar and cord type can be interchanged after delivery without damage to upholstery. (Bar type cannot be used with opera seats.)	
Bar type Ducoed to match upholstery. (Must be ordered before body leaves factory. No charge	
Cord type to match upholstery. (Must be ordered before body leaves factory.	- No charge
<i>Ash receivers</i> —Flush type for front doors where not standard	- - - - - \$ 15
<i>Division clock</i> —French walnut case	- - - - 40

NOTE: All of the above extra charges are *list*, subject to special discount applying on extra charges covering special features on Fleetwood line.

Service

FLEETWOOD bodies are built with maximum care and close inspection in every detail of their construction to the end that the maximum of service and comfort will be rendered to every owner.

In addition to this careful manufacturing policy, service facilities have been arranged with the Fisher Body Corporation in order that all Fleetwood owners may have Fleetwood body service available in their respective communities. In addition to the parts depots in the factories at Detroit and Fleetwood, which service the East, Central West, and South, Fisher Body Corporation has a parts depot at Oakland, California, to service the Pacific coast country.

These facilities reduce the time element in correspondence and transportation to secure equipment necessary to restore the body to use.

There are also seven Service Headquarters located in New York, Detroit, Atlanta, Kansas City, Dallas, Minneapolis, and Oakland, from which points Fisher men operate, these men being thoroughly familiar with Fleetwood bodies and competent to properly make any repairs or adjustments.

U3-4

File Reference JAN. 1930

General Motors Corporation

Research Laboratories

Detroit, Mich.

DATA BOOK

INTRODUCTION

These specifications of General Motors cars were originally compiled to furnish a convenient manual of useful information to the personnel of the Research Laboratories. To insure the accuracy of the data each Division was asked to supply the information on its products. In return for this the chief engineer or whoever he might designate has been furnished with a copy of the complete data.

The books have a limited distribution and the names of all persons holding copies are given on page 25.

While every precaution is taken that errors do not occur, it sometimes happens that they do creep in. New sheets are checked against the original data from the Divisions and the sheets are looked over for any apparent errors in the originals. Except for these checks, the book contains the original values given by the Divisions.

It is hoped that curves run under conditions set up in the General Motors Engine Test Code can hereafter be included and that data from the different engineering departments will then be directly comparable.

A good supply of current sheets is always kept on hand and a limited supply of old ones. Consequently, any reasonable request for sheets whether old or new can be supplied.

If any errors or changes in the specifications are found, communicate with the Technical Data Section of the Research Laboratories, Detroit.

INDEX

INTRODUCTION	1
INDEX	2
CHEVROLET, Specifications	3
Curves (Not available 3-10-30)	4
PONTIAC, Specifications	5
Curves	6
OLDSMOBILE, Specifications	7
Curves	8
MARQUETTE, Specifications	9
Curves	10
OAKLAND, Specifications	11
Curves	12
BUICK 40, Specifications	13
Curves	14
BUICK 50 & 60, Specifications	15
Curves	16
VIKING, Specifications	17
Curves	18
LASALLE, Specifications	19
Curves	20
CADILLAC 353, Specifications	21
Curves	22
CADILLAC 452, Specifications	23
Curves	24
DISTRIBUTION LIST	25

CAR	1930 CHEVROLET	
WHEELBASE	107	
TIRES Size	4.75-19	
Rolling Cir.	7.38	
Make & Pressure	Goodyear & Goodrich at 35 lbs.	
ROAD CLEARANCE	8-3/8	
TURNING RADIUS, R. & L.	19-3/4	
WEIGHTS Front	1241	
Rear	1431	
Total Road	2672	
SPRINGS Front	Semi-Ell. 36 x 1-3/4	
Rear	Semi-Ell. 54 x 1-3/4	
ENGINE Size	6 3-5/16 x 3-3/4	
Displacement	194	
Weight	479	
Compression Ratio	5.017	
Cylinder Offset	None	
Balancer	Yes	
Counterbalanced	No	
Main Bearings Length	1-3/4, 2, 2-3/16	
Main Bearing Dia.	1-15/16, 2, 2-1/16	
Conn. Bearings L. & Dia.	1-3/8 x 2	
Conn. Rod Length	7	
Piston Material	Cast Iron	
Valves: Head Diam.	In. 1-29/64	Ex. 1-11/32
Port Diam.	In. 1-5/16	Ex. 1-13/64
Seat Angle	45°	
Lift	.277	
Lash	In. .058	Ex. 008
Valve Timing: IO	4° ATC	
IC	42° ABC	
EO	47° BBC	
EC	4° ATC	
Initial Spark Setting	12° BTC	
Firing Order	1-5-3-6-2-4	
Carburetor Make & Size	Carter 1"	
Oil Capacity	5-1/2 qts. - 5 qts. refill	
Water Capacity	10 qts.	
GEAR RATIOS: Low	*18-27	*3.32:1
Second	25-20	1.77:1
Reverse	14-18, 15-31, 19-27	4.2:1
Rear Axle	10-41	4.1

NOTES: Engine weight includes everything attached to engine less transmission and clutch. Car weights of two door five passenger sedan including gas, oil and water with spare tire but no passengers from Chevrolet *Gear Ratios: First figures are number of teeth in driver to number of teeth in driven gears, second figures are gear ratios B.H.P., B.M.E.P. and torque values are not yet available. DATA from Chevrolet Engineering Department, March 1930.

CAR	1930 PONTIAC	
WHEELBASE	110	
TIRES Size	29 x 5.00	
Polling Cir.	7.46	
Make & Pressure	32 lbs. minimum F & R	
ROAD CLEARANCE	8-1/2	
TURNING RADIUS	19'-11"R, 19'-7"L	
WEIGHTS Front	1292	
Rear	1503	
Total Road	2800	
SPRINGS Front	Semi-Ell. 36 x 2	
Rear	Semi-Ell. 54 x 2	
ENGINE Size	6 3-5/16 x 3-7/8	
Displacement	200	
Weight		
Max. B.H.P.	60 at 3000	
Max. B.M.E.P.	97 at 1000	
Max. Torque	129 at 1000	
Compression Ratio	4.9	
Cylinder Offset	No	
Balancer	Yes	
Counterbalanced	Yes	
Main Bearings Length	1-5/8, 2, 2	
Main Bearing Dia.	1-15/16, 2, 2-1/16	
Conn. Rod Bearings L. & Dia	1-5/16 x 2 1-7/16 x 2-1/16	
Connecting Rod Length	7-5/16	
Piston Material	Cast Iron	
Valves: Head Diam.	In. 1-13/32 Ex. 1-11/32	
Port Diam.	In. 1-1/4 Ex. 1-3/16	
Seat Angle	45°	
Lift	5/16	
Lash	In. .007 Ex. .009	
Valve Timing: IO	7° ATC	
IC	39° ABC	
EO	42° BBC	
EC	7° ATC	
Initial Spark Setting	4° BTC	
Firing Order	1-5-3-6-2-4	
Carburetor Size and Make	Marvel 1-1/4	
Oil Capacity	6 qts.	
Water Capacity	14 qts.	
GEAR RATIOS: Low	*18-27	*3.32:1
Second	25-20	1.77:1
Reverse	18-27	4.21:1
Rear Axle	12-53	4.41:1

NOTES: Car weights for 2 door sedan including water, oil, gasoline, spare tire, bumpers, spring covers and spare tire cover, B.M.E.P. and torque values from curves in this book. *Gear Ratios: First figures are number of teeth in driver to number of teeth in driven gear. Second figures are gear ratios.

DATA from Oakland Engineering Department, February 1930.

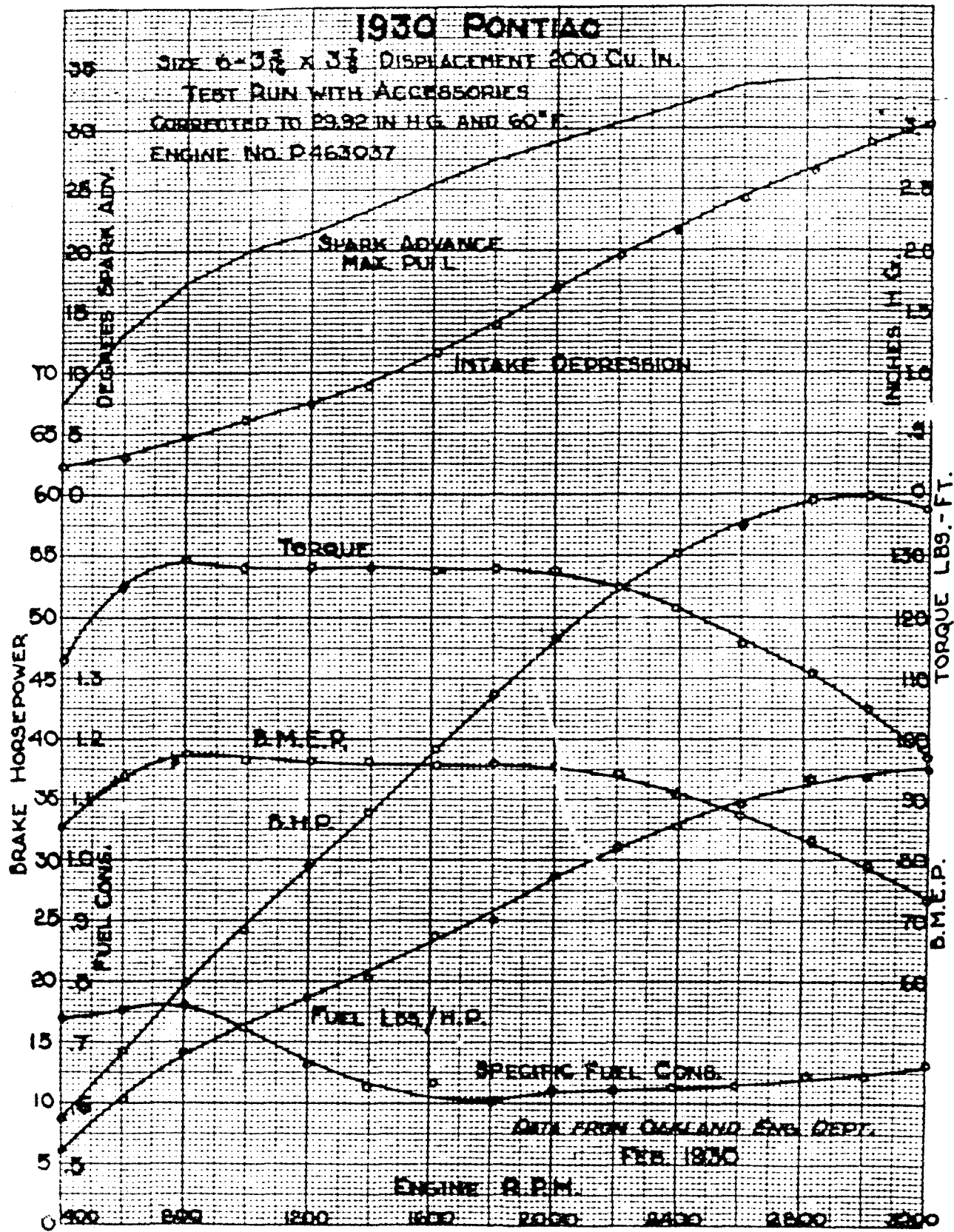

CAR	1930 OLDSMOBILE	
WHEELBASE	113-1/2	
TIRES Size	28 x 5.25	
Rolling Cir.	7.225	
Make	U. S. at 35 $\frac{7}{8}$	
ROAD CLEARANCE	8	
TURNING RADIUS, R. & L.	19-1/2	
WEIGHTS Front	1436	
Rear	1532	
Total Road	2968	
SPRINGS Front	Semi-Ell. 35" x 2"	
Rear	Semi-Ell. 54-1/2 x 2	
ENGINE Size	6 3-3/16 x 4-1/8	
Displacement	197.5	
Weight	533	
Max. B.M.P.	61.5 at 3200	
Max. B.M.E.P.	95 at 1100	
Max. Torque	125 at 1100	
Compression Ratio	5.2	
Cylinder Offset	None	
Balancer	No	
Counterbalanced	Yes 40%	
Main Bearings Length	1-3/4, 1-3/4, 1-3/4, 2-5/16	
Main Bearing Dia.	2-1/4, 2-5/16, 2-7/16, 2-1/2	
Conn. Rod Bearings L. & Dia.	1-3/8 x 1-7/8	
Connecting Rod Length	9	
Piston Material	Cast Iron	
Valve: Head Diam.	In. 1-17/32	Ex. 1-13/32
Port Diam.	In. 1-5/16	Ex. 1-1/4
Seat Angle	In. 30°	Ex. 30°
Lift	In. .320	Ex. .320
Lash	In. .008	Ex. .010
Valve Timing: IO	_____	TDC
IC	_____	50° ABC
EO	_____	40° BBC
EC	_____	10° ATC
Initial Spark Setting	_____	8° BTC
Firing Order	1-5-3-6-2-4	
Carburetor Make & Size	Johnson 1-1/4	
Oil Capacity	6 qts.	
Water Capacity	13 qts.	
GEAR RATIOS: Low	3	
Second	1.75	
Reverse	3.857	
Rear Axle	4.54 (50-11)	

NOTES: Engine weight complete except transmission, clutch and housing. Car weight from Oldsmobile for 2-door 5-passenger sedan including gas, oil and water, spare tire, bumpers and tools but no passengers. Torque, B.H.P. and B.M.E.P. values from performance curves in this book.

DATA from Oldsmobile Engineering Department, January 1930.

SPARK ADVANCE

HORSE POWER

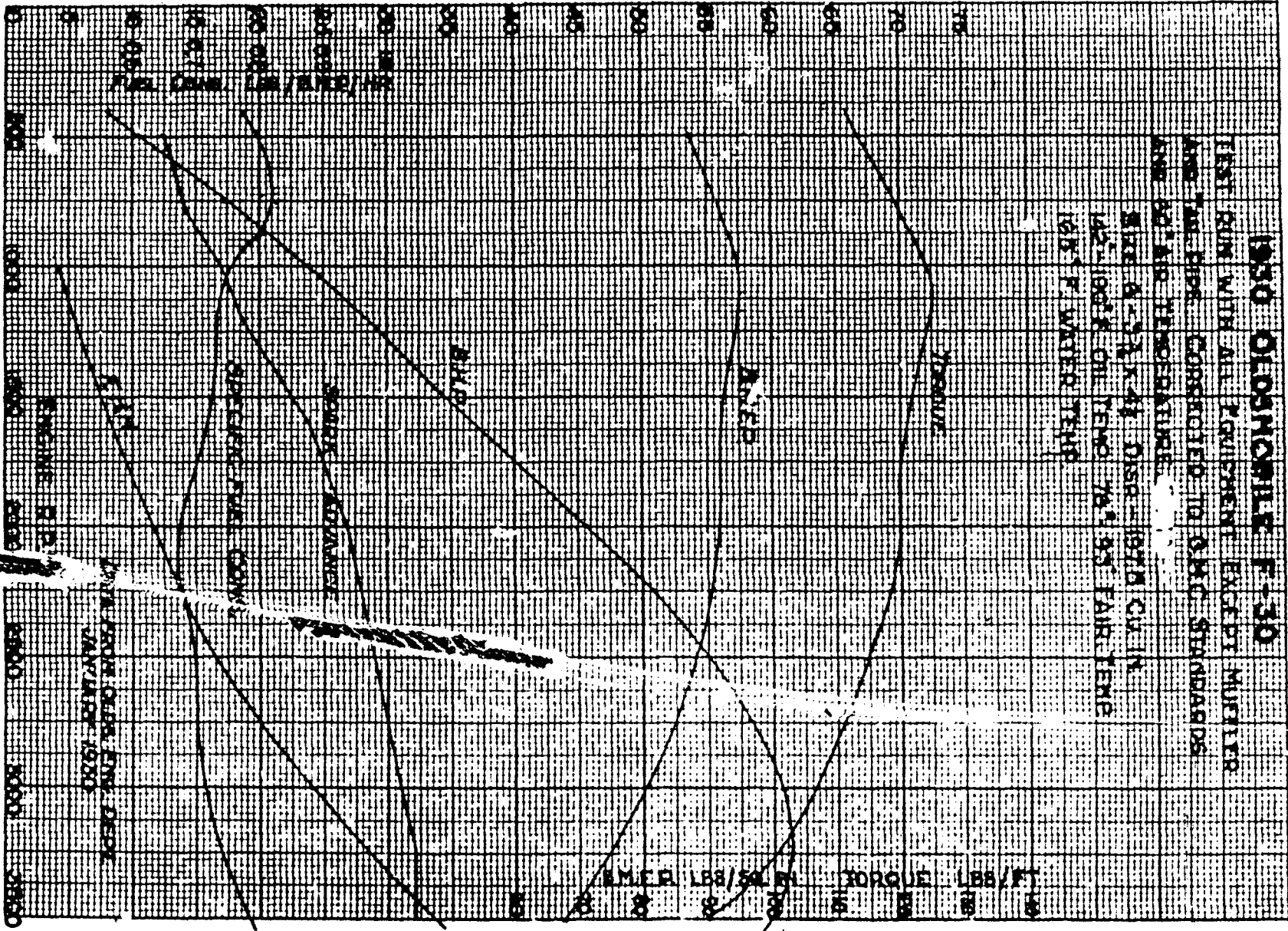

CAR 1930 MARQUETTE

WHEELBASE	114	
TIRES Size	28 x 5.25	
Rolling Cir.	7.27	
Make		
ROAD CLEARANCE	8	
TURNING RADIUS, R. & L.	19.3	
CURB WEIGHTS Front	1482.25	
Rear	1649.75	
Total Road	3132	
SPRINGS Front	Semi-Ell. 35 x 2	
Rear	Semi-Ell. 54-1/2 x 2	
ENGINE Size	6 3-1/8 x 4-5/8	
Displacement	212.8 Cu. in.	
Weight	603	
Max. B.H.P.	67.5 at 3000	
Max. B.M.E.P.	102 at 1000	
Max. Torque	144.5 at 1000	
Compression Ratio	5.2	
Cylinder or piston offset	Piston Pin 3/32	
Balancer	No.	
Counterbalanced	Yes	
Main Bearings Length	1-15/32, 1-1/2, 1-1/2, 1-29/32	
Main Bearing Dia.	2-5/16, 2-3/8, 2-1/2, 2-9/16	
Conn. Rod Bearings L. & Dia.	1-3/8, 2-1/8	
Connecting Rod Length	9-3/4	
Piston Material	Cast Iron	
Valves: Head Diam.	1-5/8 In. Ex. 1-1/2	
Port Diam.	1-1/2 In. Ex. 1-3/8	
Seat Angle	45°	
Lift	.324	
Lash (Hot)	.006	
Valve Timing: IO	5° BTC	
IC	45° ABC	
EO	45° BBC	
EC	18° ATC	
Initial Spark Setting	7° Advance	
Firing Order	1-5-3-6-2-4	
Carburetor Make & Size	Marvel V. M.	
Oil Capacity	7 qts.	
Water Capacity	3 gallons	
GEAR RATIO: Low	3.60 to 1	
Second	1.75 to 1	
Reverse	3.857 to 1	
Rear Axle	50-11 or 4.545 to 1	

NOTES: Car weight from Buick for five passenger 2-door sedan with gas, oil and water, spare tire, bumpers, tools, but no passengers. Engine weight includes everything attached to engine as used in the car less transmission and clutch. B.M.E.P., B.H.P. and torque from curves in this book.

DATA from Buick Engineering Department, July 1929.

1930 MARQUETTE

NO. 0524 45
CORRECTION 1.2

DEPT. 2128 CLIN.
CORR. 35 LBS 130 IN

DEPT. FOR ALL REGULAR EQUIPMENT EXCEPT
BARILATOR AND TANK

DEPT. TO 23.02 BARILATOR AND 60° TEMP.

FORMULA

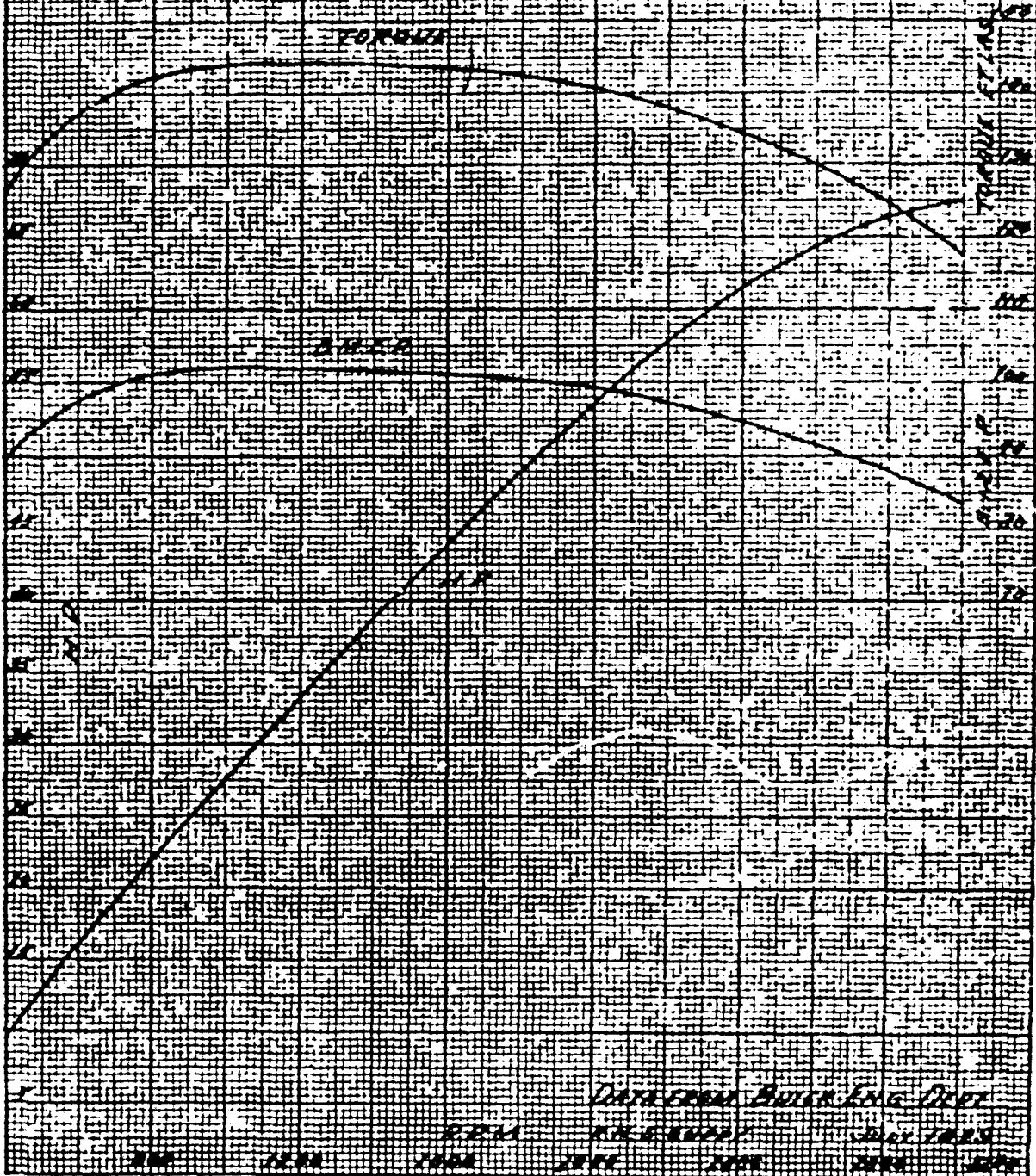

TEMPERATURE
100
110
120
130
140
150
160
170
180
190
200
210
220
230
240
250
260
270
280
290
300

DATE FROM AUTO LOG DEPT.
DEPT. 2128 CLIN. 1930

CAR	1930 OAKLAND	
WHEELBASE	117	
TIRES Size	28 x 5.50	
Rolling Cir.	7.3	
Pressure	34 lbs.	
ROAD CLEARANCE	8-1/8	
TURNING RADIUS	20'-2" R, 20'-5" L.	
WEIGHTS Front	1608	
Rear	1645	
Total Road	3253	
SPRINGS Front	Semi-Ell. 36 x 2	
Rear	Semi-Ell. 54-1/2 x 2	
ENGINE Size	V-8 3-7/16 x 3-3/8	
Displacement	251	
Weight	789	
Max. B.H.P.	79 at 3200	
Max. B.M.E.P.	94 at 1200	
Max. Torque	156 at 1200	
Compression Ratio	5.0	
Cylinder Offset	None	
Balancer	No	
Counterbalanced	Yes - Correct	
Main Bearings Length	2-1/4, 2-3/8, 2-5/8	
Main Bearing Diam.	2-1/4, 2-5/16, 2-3/8	
Conn. Rod Bearings L. & Dia.	1-1/4 x 2-1/4	
Connecting Rod Length	6-5/8	
Piston Material	Cast Iron	
Valves: Head Diam.	In. 1-1/2 Ex. 1-3/8	
Port Diam.	In. 1-3/8 Ex. 1-1/4	
Seat Angle	45°	
Lift	.33	
Lash	In. .011 Ex. 013	
Valve Timing: IO	TC	
IC	40° ABC	
EO	45° EBC	
EC	15° ATC	
Initial Spark Setting	7° BTC	
Firing Order	1-4-5-2-7-6-3-8	
Carburetor Make & Size	Marvel 1-3/4	
Oil Capacity	7 qts.	
Water Capacity	25 qts.	
GEAR RATIOS: Low	*18-27	*3:1
Second	24-21	1.75:1
Reverse	14-27	3.85:1
Rear Axle	53-12	4.42:1

NOTES: Car weight for five passengers, 2-door sedan including water, oil, gasoline, spare tire, bumpers, spring covers and spare tire cover. Curves from dynamometer engine. B.M.E.P and torque from curves in this book. *Gear Ratios: First figures are number of teeth in driver to number of teeth in driven gear. Second figures are gear ratios.

1930 OAKLAND V-8

SIZE 8-3/4 X 5-3/8 DISP 251 CU IN.

COMP. RATIO 8.0:1 AVG COMP. PRESS (CORR) 108 LBS. SQ. IN. GM. GA.
 CORR. TO 29.92 BARO. AND 100° F.

TEST RUN WITHOUT MUFFLER, TAIL PIPE BUT WITH COOLING
 FAN, AIR CLEANER, GENERATOR, WATER AND OIL PUMPS
 ENGINE FROM CAR 101-1

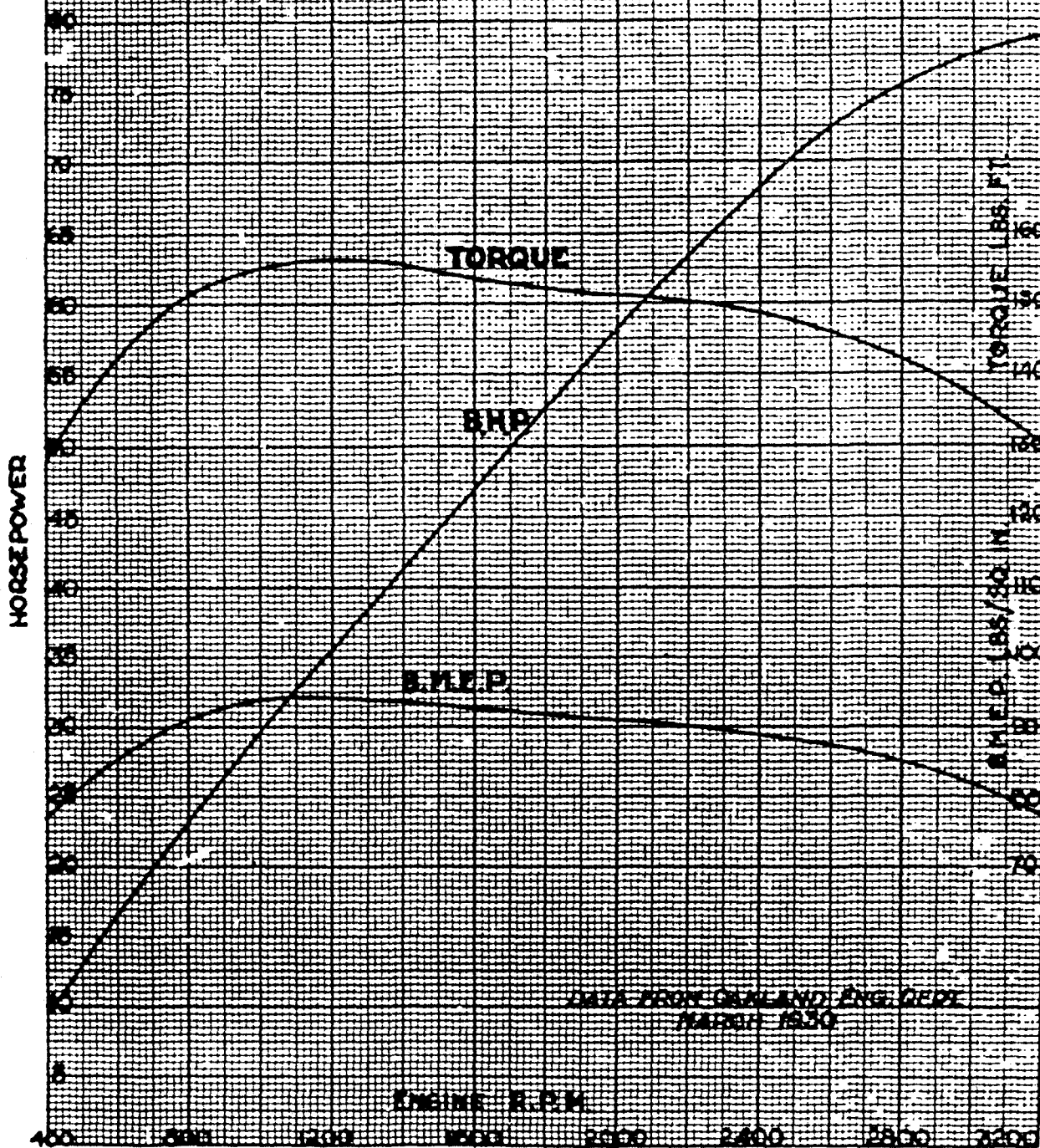

DATA FROM OAKLAND ENG. DEPT
 MARCH 1930

ENGINE R.O.M.

C.R.	1930 Buick Series 40
WHEELBASE	118
TIRES Size	29 x 5.50
Rolling Cir.	7,696
Make	Goodrich at 36 lbs.
ROAD CLEARANCE	8-9/16
TURNING RADIUS, R. & L.	19-3/4
CURB WEIGHTS Front	1873
Rear	1987
Total Road	3860
SPRINGS Front	Semi-Ell. 36-3/8 x 2
Rear	Semi-Ell. 55 x 2-1/4
ENGINE Size	3-7/16 x 4-5/8
Displacement	257.5
Weight	746 Less Oil
Max. B.H.P.	69 at 2800
Max. B.M.E.P.	101 at 900
Max. Torque	173 at 1200
Compression Ratio	4.5
Cylinder or piston offset	Piston Pin 3/32
Balancer	Yes
Counterbalanced	Yes
Main Bearings Length	2-1/4, 1-5/8, 1-11/16, 2-9/16
Main Bearing Diameter	2-3/8 All
Conn. Rod Bearings L. & D.	1-1/2 x 2-1/8
Conn. Rod Length	10
Piston Material	Cast Iron
Valves: Head Diameter	1.7157 Both
Port Diameter	1.5625 Both
Seat Angle	45°
Lift	.337
Lash (Hot)	.008
Valve Timing: IO	1° ITC
IC	51° ABC
EO	52° BBC
EC	23° ITC
Initial Spark Setting	15° Advance
Firing Order	1-4-2-6-3-5
Carburetor Make & Size	Marvel 1-7/16 Throttle Diam 1-1/4 Port Diam.
Oil Capacity	7-1/2 qts dry, 5-1/2 refill
Water Capacity	4 gallons
GEAR RATIOS: Low	3.070 to 1
Second	1.824 to 1
Reverse	3.684 to 1
Rear Axle	4.545 (50-11)

NOTES: Car weights from Buick for five passenger, 2-door sedan including gas, oil and water, spare tire, bumpers, tools, but no passengers. Engine weights include everything attached to engine as used in the car less transmission and clutch. B.H.P., B.M.E.P., and torque from curves in this book.

DATA from Buick Engineering Department, September 1929.

CAR	1930 Buick Series 50-60	
WHEELBASE	124 - 132	
TIRES Size	19 x 6.50	
Rolling Cir.	8.062	
Make	Firestone at 36 lbs.	
ROAD CLEARANCE	8-13/16	
TURNING RADIUS, R. & L.	21-3/8 - 22-3/4	
CURB WEIGHTS Front	M-57 2152	M-61 2236
Rear	2366	2379
Total Road	4512	4615
SPRINGS Front	Semi-Ell. 37-1/8 x 2	
Rear	Semi-Ell. 58-1/4 x 2	
ENGINE Size	6 3-3/4 x 5	
Displacement	331	
Weight	906 Less Oil	
Max. B.H.P.	88 at 2800	
Max. B.M.E.P.	102 at 1200	
Max. Torque	226 at 1200	
Compression Ratio	4.35	
Cylinder or Piston Offset	Piston Pin 3/32	
Balancer	Yes	
Counterbalanced	Yes	
Main Bearing Length	2-7/16, 1-13/16, 1-7/8, 2-23/32	
Main Bearing Diam	2-1/2 in	
Conn. Rod Bearings L. & D.	1-3/4 x 2-3/8	
Conn. Rod Length	11-1/4	
Piston Material	Cast Iron	
Valves: Head Diam	In. 2.028	Ex. 1.784
Port Diam	In. 1.8755	Ex. 1.625
Seat Angle	45°	
Lift	.537	
Lash (Hot)	.008	
Valve Timing: IO	17°	54' ATC
IC	52°	30' ABC
EO	50°	30' BBC
EC	20°	4' ATC
Initial Spark Setting	17° Advance	
Firing Order	1-4-2-6-3-5	
Carburetor Make & Size	Marvel 1-3/4 Throttle Diam. 1-1/2 Man. Diam.	
Oil Capacity	8 qts dry 6 qts. refill	
Water Capacity	5-1/2 gallons	
GEAR RATIOS: Low	3.091	
Second	1.794	
Reverse	3.915	
Rear Axle	M-57 (47-11)	4.272
	M-61 (49-11)	4.455

NOTES: Car weights from Buick for five passenger 4-door sedan including gas, oil, water, spare tire, bumpers and tools but no passengers. M-61 for 7 passenger sedan. Engine weights include everything attached to engine as used in the car less transmission and clutch. B.M.E.P. B.H.P., and torque figures from performance curves in this book.

DATA from Buick Engineering Department, September 1929.

1930 BUICK SERIES 50 AND 60

SIZE 37 X 5

DISP 331.5 CU. IN.

CORR. TO 29.92 L.A.R.O. AND 60° AIR TEMP.

ENGINE WITHOUT MUFFLER SOME PRESS. 81.3 @ 1000 R.P.M.

AVERAGE CURVES FROM 14 ENGINES

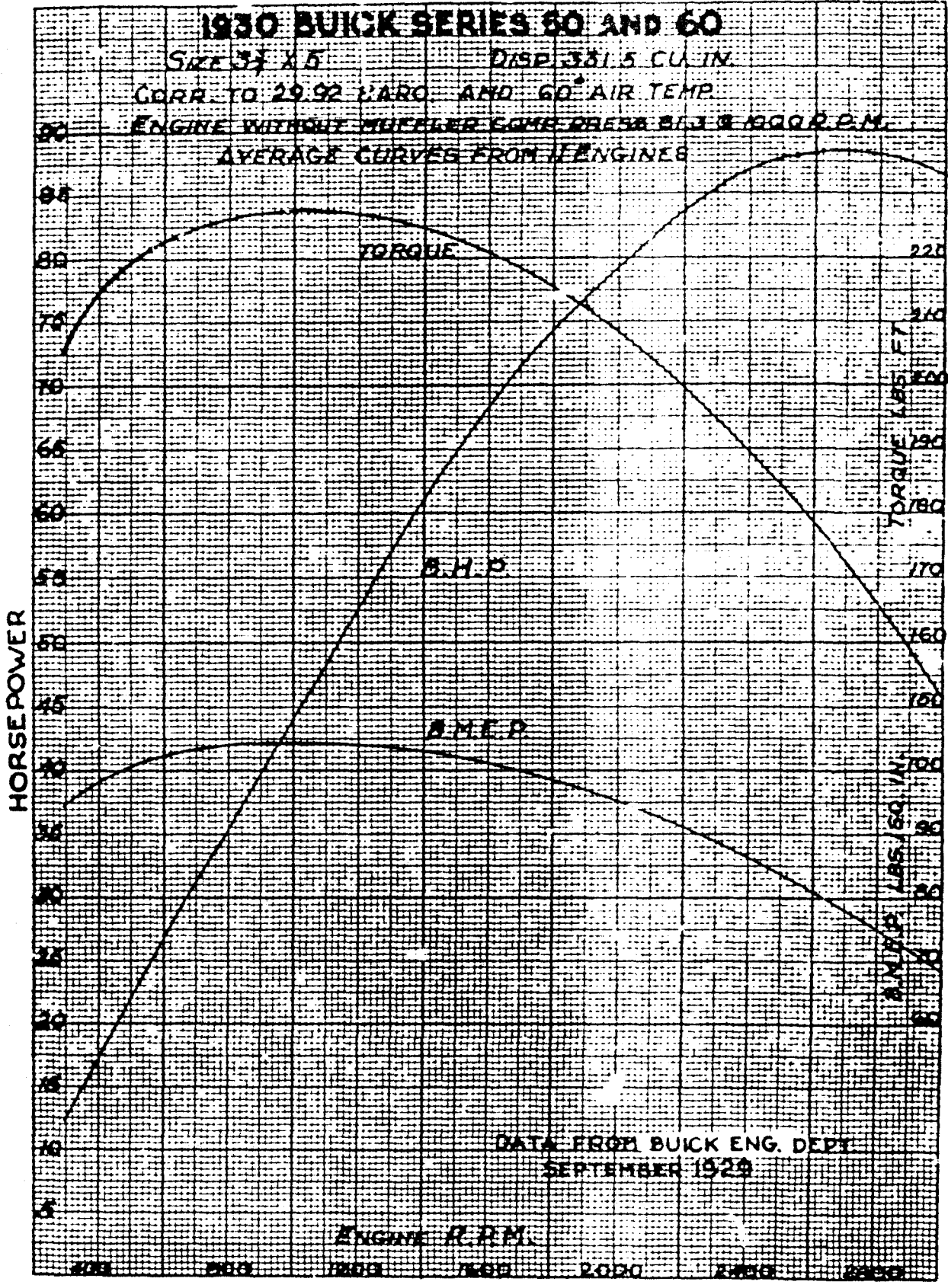

DATA FROM BUICK ENG. DEPT.
SEPTEMBER 1929

ENGINE R.P.M.

400 800 1200 1600 2000 2400 2800

CAR	1930 VIKING	
WHEELBASE	125	
TIRES Size	30 x 6.00	
Rolling Cir.	7.48	
Make	35 lbs. rear & 40 lbs. front	
ROAD CLEARANCE	8	
TURNING RADIUS, R. & L.	21-1/4	
WEIGHTS Front	1795	
Rear	2037	
Total Road	3832	
SPRINGS Front	Semi-Ell. 37" x 2"	
Rear	Semi-Ell. 58" x 2"	
ENGINE Size	V-8 3-3/8 x 3-5/8	
Displacement	259.5	
Weight	700 lbs.	
Max. B. H. P.	81 at 3200	
Max. B.M.E.P.	102.75 at 1200	
Max. Torque	176 at 1200	
Compression Ratio	5.1	
Cylinder Offset	None	
Balancer	No	
Counterbalanced	Yes 100%	
Main Bearings Length	1-7/8, 2-1/2, 3-3/8	
Main Bearing Diameter	2-1/4, 2-3/8, 2-1/2	
Conn. Rod Bearing L & Dia	1-3/8 x 2	
Connecting Rod Length	7-1/8	
Piston Material	Cast Iron	
Valves: Head Diam.	In. 1-15/32	Ex. 1-11/32
Port Diam.	In. 1-5/16	Ex. 1-3/16
Seat Angle	In. 30°	Ex. 30°
Lift	In. .340	Ex. .336
Lash	In. .008	Ex. .010
Valve Timing: IO	1°	- 20' BTC
IC	51°	- 20' ABC
(.010 Lash) EO	41°	- 20' EBC
EC	11	- 20' ATC
Initial Spark Setting	.055 BTC	
Firing Order	1R-4L-4R-2R-3L-3R-2L-1L	
Carburetor Make & Size	Johnson 1-1/2	
Oil Capacity	7 qts.	
Water Capacity	32 qts.	
GEAR RATIOS: Low	3.11	
Second	1.69	
Reverse	3.78	
Rear Axle	4.63 (11-51)	

NOTES: Engine weight complete except transmission, clutch and housing. Car weight from Oldsmobile for 4-door 5-passenger sedan including gas, oil and water, spare tire, bumpers and tools but no passengers. Torque, B.H.P and B.M.E.P values from performance curves in this book.

DATA from Oldsmobile Engineering Department, January 1930.

EUGENE DIETZGEN CO CORP
Chicago and New York 1922

EDCO ENGINEERING
20 X 20

NO 340 20

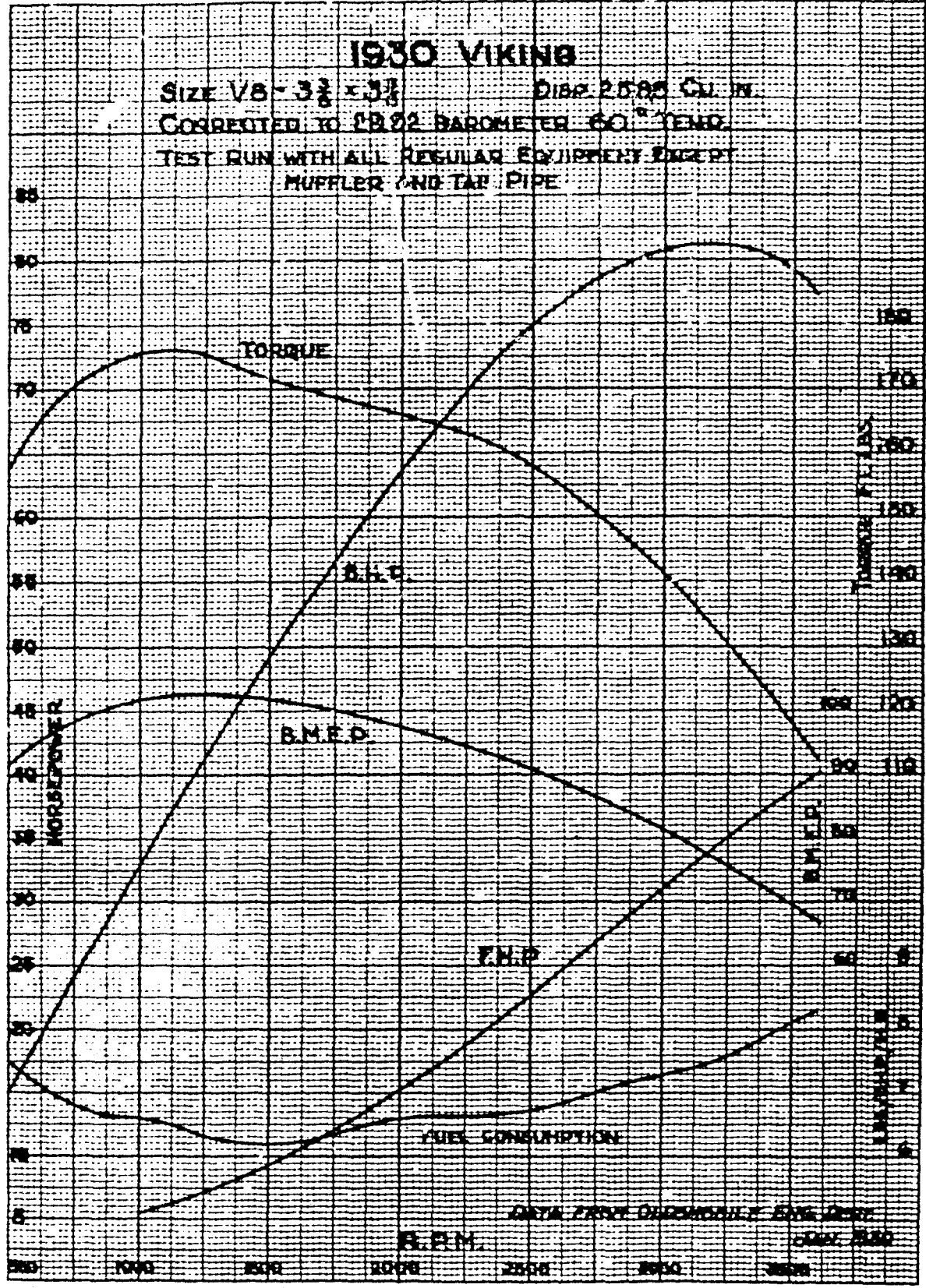

CAR	1930 LaSalle 340
WHEELBASE	134
TIRES Size	6.50 - 19 Wood Wheels 7.00 - 18 others
Rolling Cir.	7.925
Make	U.S. at 40 lbs. 7.00-18
ROAD CLEARANCE	7-23/32
TURNING RADIUS	R. 23' - 1", L. 24' - 8"
WEIGHTS Front	2234
Rear	2733
Total Road	4967
SPRINGS Front	Semi-Ell. 38 x 2
Rear	Semi-Ell. 56 x 2
ENGINE Size	V-8 - 3-5/16 x 4-15/16
Displacement	341
Weight	701.5
Max. B.H.P.	91.5 at 3000
Max. B.M.E.P.	94 at 900
Max. Torque	211 at 900
Compression Ratio	5.18 Std. 4.92 Opt.
Cylinder Offset	None
Balancer	No
Counterbalanced	Yes
Main Bearings Length	1-5/16, 1-5/8, 2-7/8
Main Bearing Dia.	2-3/8
Conn. Rod Bearing L. & Dia.	1-3/8 x 2-3/8
Connecting Rod Length	10-1/2
Piston Material	Nickel Cast Iron
Valves: Head Diam.	In. 1.66 Ex. 1.63
Port Diam.	In.
Seat Angle	In. 30° Ex. 45°
Lift	23/64
Lash (Cold)	In. .004 Ex. .006
Valve Timing: IO	11° BTC
IC	59° ABC
EO	48° BBC
EC	8° ATC
Initial Spark Setting	7° 20' ETC
Firing Order	1R-4L-4R-2R-3L-3R-2L-1L
Carburetor Make & Size	Own 2"
Oil Capacity	8 qts.
Water Capacity	6 gallons
GEAR RATIOS: Low	2.96
Second	1.79
Reverse	3.56
Rear Axle (59-13)	4.54 Std., 4.07, 4.91 Opt.

NOTES: Car weights of 4-door 5-passenger sedan including gas, oil, water, spare tire, bumpers and tools, but without passengers. Weights from Cadillac Engineering Dept. Engine weight includes everything attached to engine as used in a car less transmission, clutch and starter. Starter weighs 25 lbs. B.H.P., B.M.E.P., and torque values from curves in this book. DATA from Cadillac Engineering Department, December 1929.

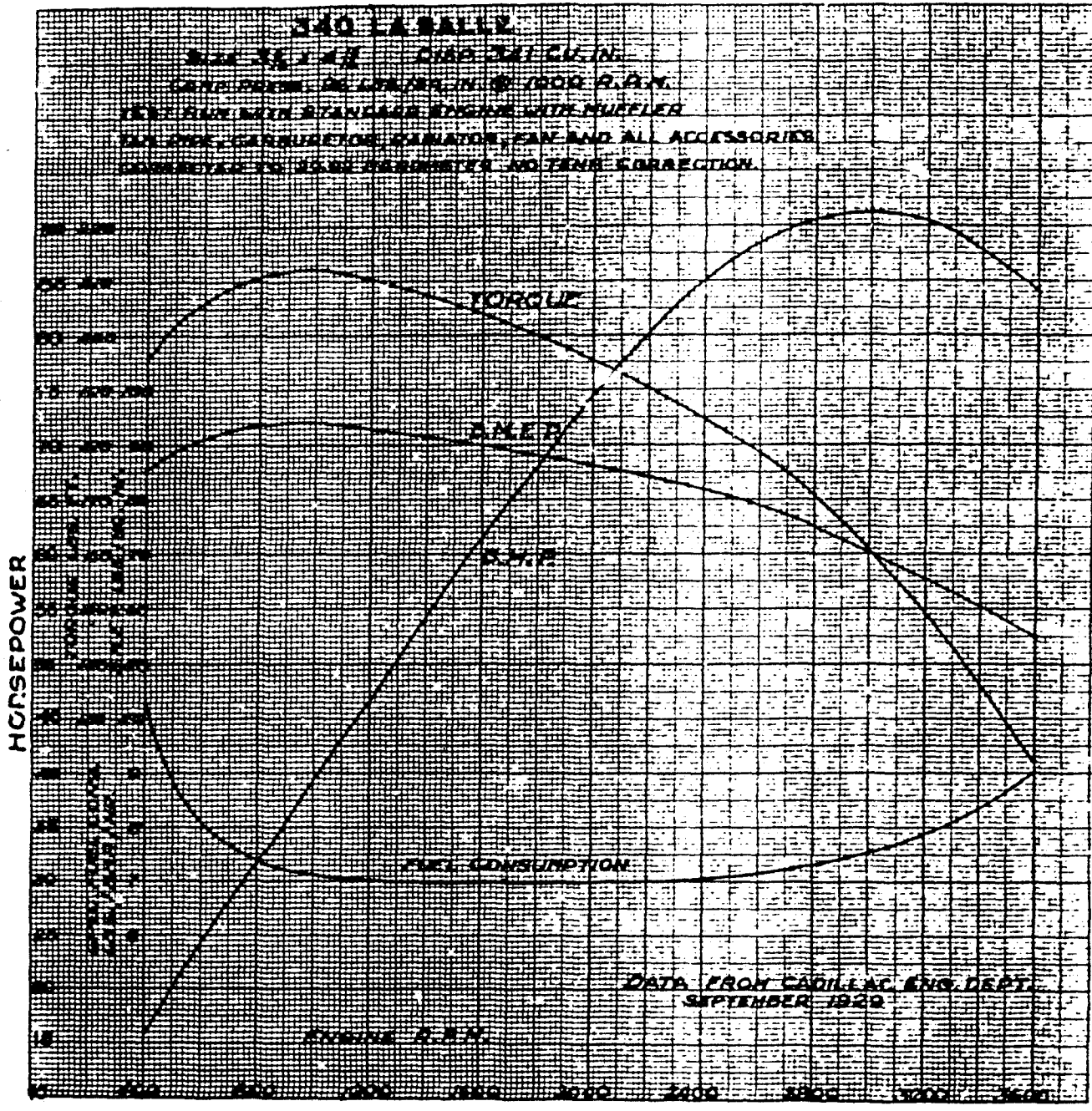

CAR

1930 CADILLAC 353

WHEELBASE	140
TIRES Size	7.00 - 19
Rolling Cir.	8.20
Make	U.S. Royal at 40 lbs.
ROAD CLEARANCE	8-3/8
TURNING RADIUS	R. 26' - 10", L. 24' - 6-1/2"
WEIGHTS Front	2770
Rear	2869
Total Road	5639
SPRINGS Front	Semi-El. 42 x 2-1/4
Rear	Semi-El. 60 x 2-1/2
ENGINE Size	V-8 3-3/8 x 4-15/16
Displacement	353 cu. in.
Weight	697.5 lbs.
Max. B.H.P.	94.5 at 2900
Max. B.M.E.P.	97 at 1000
Max. Torque	224 at 1000
Compression Ratio	5.15 Std., 5.03 Opt.
Cylinder Offset	None
Balancer	No
Counterbalanced	Yes
Main Bearings Length	1-5/16, 1-5/8, 3/7/8
Main Bearing Dia.	2-3/8
Conn. Rod Bearings L. & Dia.	1-3/8 x 2-3/8
Connecting Rod Length	10-1/2
Piston Material	Nickel Cast Iron
Valves: Head Diam.	In. 1.66 Ex. 1.63
Port Diam.	
Seat Angle	In. 30° Ex. 45°
Lift	23/64
Lash (Cold)	In. .004 Ex. .006
Valve Timing: IO	11° BTC
IC	59° ABC
EO	48° BBC
EC	8° ATC
Initial Spark Setting	7° 20° BTC
Firing Order	1R-4L-4R-2R-3L-3R-2L-1L
Carburetor Make & Size	Own 2"
Oil Capacity	8 qts.
Water Capacity	6 gallons
GEAR RATIO: Low	2.96
Second	1.79
Reverse	3.56
Rear Axle (61-12)	5.06 Std. 4.39, 4.75 Opt.

NOTES: Car weight of 4-door 5-passenger sedan, with wire wheels including gas, oil and water, spare tire, bumpers and tools, but without passengers. Weights from Cadillac Engineering Dept. Engine weight includes everything attached to engine as used in car except transmission, clutch and starter. Starter weighs 25 lbs. B.H.P., B.M.E.P., and torque values from curves in this book.

DATA from Cadillac Engineering Department, December 1929.

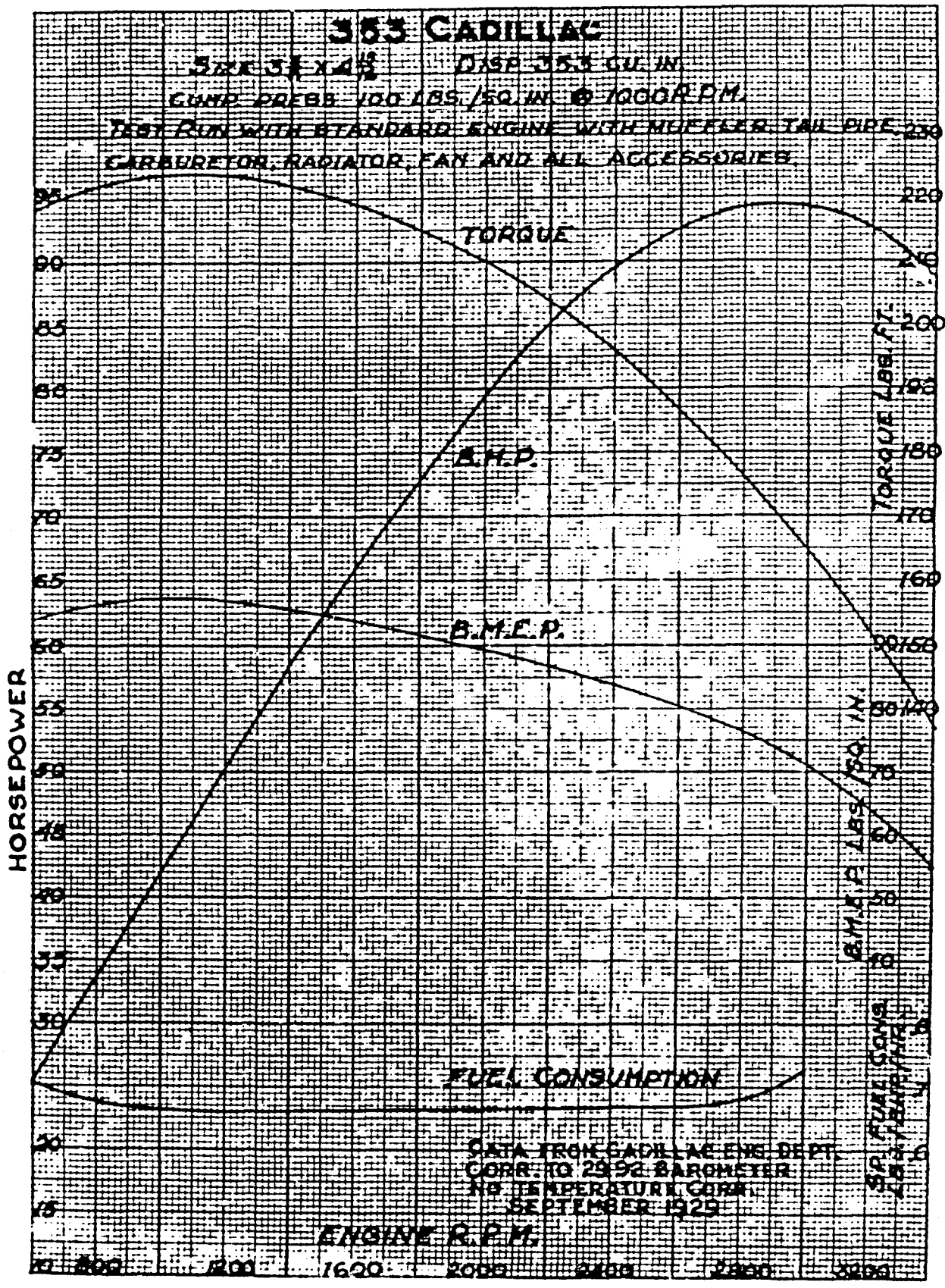

CAR	CADILLAC 452
WHEELBASE	148
TIRES Size	7.00 - 19
Rolling Cir.	8.20
Make	U.S., Goodyear, Firestone, F. 45-lbs. R-40 lbs
ROAD CLEARANCE	8-3/8
TURNING RADIUS	
WEIGHTS Front	
Rear	
Total Road	
SPRINGS Front	Semi-Ell. 42 x 2-1/4
Rear	Semi-Ell. 60 x 2-1/2
ENGINE Size	16-3 x 4
Displacement	452
Weight	
Max. B.H.P.	161 at 3400
Max. B.M.E.P.	106 at 1400
Max. Torque	318 at 1400
Compression Ratio	5.5
Cylinder Offset	None
Balancer	Yes
Counterbalanced	Yes
Main Bearings Length	2-3/16, 1-3/8, 1-1/2, 1-3/8, 3-9/16
Main Bearing Diam	2-5/8
Conn. Rod Bearings L. & D.	1-1/32 x 2-1/2
Connecting Rod Length	9.25
Piston Material	Nickel Cast Iron
Valves: Head Diam.	1.45
Port Diam.	
Seat Angle	45°
Lift	11/32
Lash (Hot)	0
Valve Timing: IO	TDC
IC	44° ABC
O Lash EO	39° BBC
EC	5° ATC
Initial Spark Setting	10-1/2° BTC
Firing Order	1-8-9-14-3-6-11-2-15-10-7-4-13- 12-5-16
Carburetor Make & Size	Own Two 1-1/2"
Oil Capacity	10 qts.
Water Capacity	7 gallons
GEAR RATIOS: Low	1.51
Second	2.50
Reverse	3.00
Rear Axle (57-13)	4.39 Opt. 4.75, 3147, 4.C7

NOTES: Cylinder Numbers Front 2-4-6-8-10-12-14-16
1-3-5-7-9-11-13-15

Torque, B.M.E.P. and B.H.P. values from curves in this book.

DATA from Cadillac Engineering Department, December 1929.

453 CADILLAC V-16
SIZE 16x3x4 DISPL 452 CU. IN.
TEST RUN ON ENGINE AND ALL ACCESSORIES
CONNECTED TO 29.92 BAROMETER
NO TEMPERATURE CORRECTION

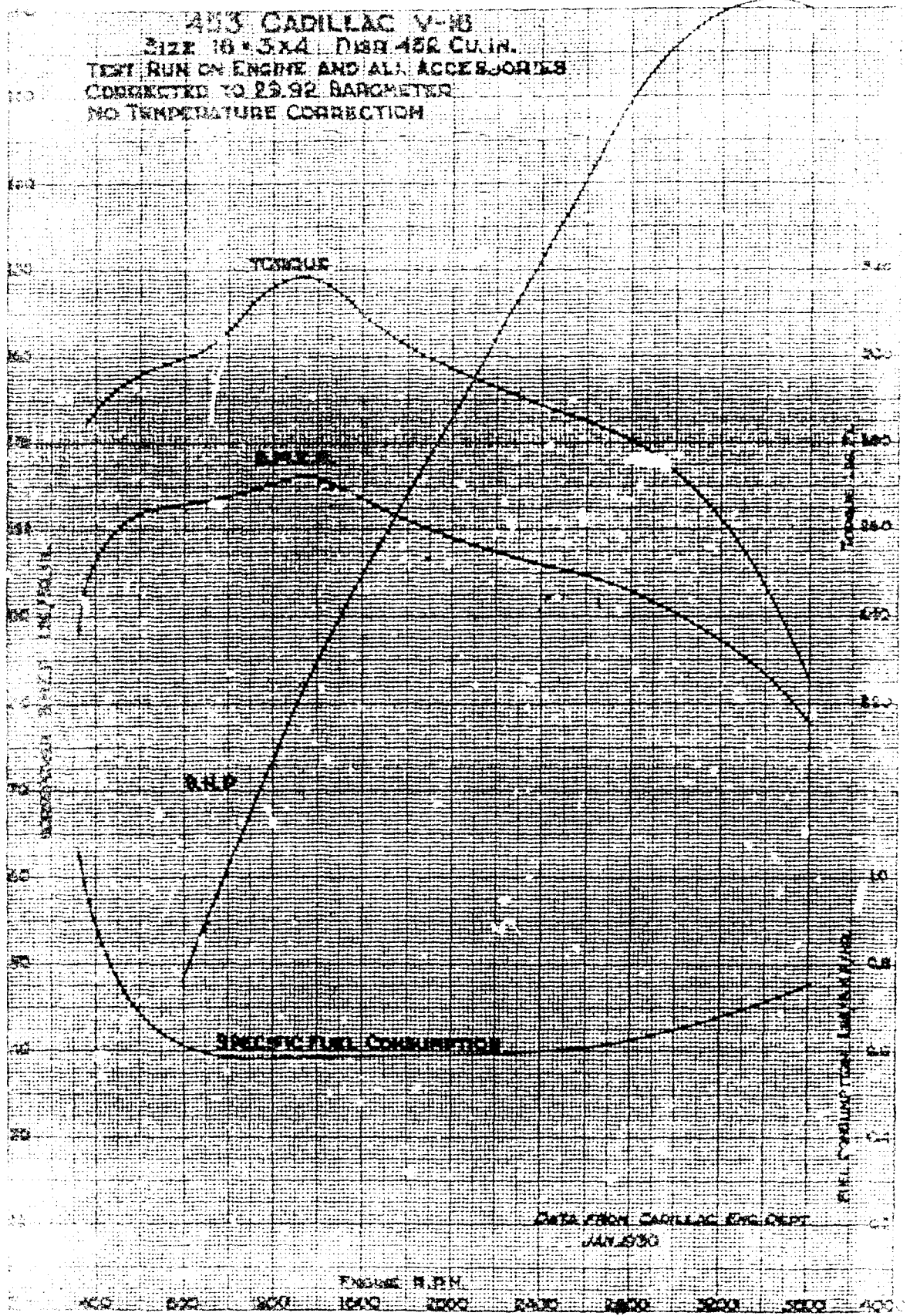

DATA FROM CADILLAC ENG. DEPT
JAN. 1930

400 600 800 1000 1200 1400 1600 1800 2000 2200 2400 2600 2800 3000 3200 3400 3600 3800 4000

DISTRIBUTION LISTCENTRAL GENERAL MOTORS

A. T. Brandt
H. M. Crane
J. B. Jackson

B. G. Koether
James McEvoy
W. J. Davidson
O. E. Hunt

DIVISIONS

A. L. Gayer
C. H. Sterling
F. C. Hecox
J. H. Hunt
D. B. Webster
R. B. Wuerfel
L. C. Oswald
G. W. Garner
W. T. Hoyle
H. F. Smith
F. H. Kane
J. G. Wood
C. L. McCuen
L. A. Walsb
R. L. McNeal
W. D. Reese (2)
A. T. Crowe

Buick
Brown-Lipe-Chapin
Cadillac
Patent Section
Chevrolet
"
Delco-Light
General Motors of Canada
" " "
" " "
Oakland
Oldsmobile
"
"
Proving Ground
Yellow Truck & Coach
G. M. Export Company

LABORATORIES

F. O. Clements
H. R. Wolf
J. O. Almen
A. W. Gardiner
A. D. Buchanan
J. Taylor
E. E. Wilson
H. W. Isire
A. A. Catlin
T. P. Chase
F. Davis
T. A. Boyd
G. E. A. Mallett
L. W. Shutts
L. Straus
C. W. Iseler
J. C. Grabfield
A. F. Underwood
G. P. Berry
F. G. Shoemaker
T. C. VanDeGrift
T. O. Richards
R. A. Richardson
C. Lutz

Technical Director
Chemical Section
Dynamics Section
" "
" "
" "
" "
Electrical Section
" "
Engineering Tests Section
" " "
Fuel Section
Power Plant Section
" " "
" " "
" " "
" " "
" " "
" " "
Special Problems Section
Technical Data Section
" " "
Library

CADILLAC

cop 2

Instruction books

19 - ed. 353-1

CADILLAC

Operator's Manual



CADILLAC MOTOR CAR COMPANY
DETROIT

Copyright 1929 by
Cadillac Motor Car Company

EDITION NO. 353-1

In ordering a duplicate of this Manual specify the
above number or the engine number of the car.

Table of Contents

CHAPTER I— <i>Cadillac Service</i>	5
Cadillac-La Salle Service Stations—Service card—Service charges—Repair parts— The owner's obligation—Lubrication—Inspection.	
CHAPTER II— <i>Operation</i>	9
Locks—Ignition switch lock—Gasoline gauge—Temperature indicator—Throttle control—Ignition control—Carburetor enriching control—Carburetor heat control —Starter pedal—Oil pressure gauge—Clutch pedal—Transmission control—Coasting —Brakes—Speedometer—Ammeter—Lighting switch—Danger of running engine in closed garage.	
CHAPTER III— <i>Equipment</i>	23
Windshield and ventilation—Windshield cleaner—Adjustable seat—Cigar lighters and inspection lamp—TOOLS—Tool compartment—TIRES—Tire valve caps— Inflation pressure—Tire air compressor—Tire carrier—Spare wheel carrier—Truing up rim—Use of jack in changing tires—Changing tires—Tire balancing marks.	
CHAPTER IV— <i>Lubrication</i>	35
Lubrication schedule—Lubrication notice—Lubrication chart—LUBRICANTS— Engine oil—Gear lubricant—Chassis grease—Wheel bearing and cup grease —ENGINE LUBRICATION—Oil level—Crankcase ventilating system and oil filter—Replacing engine oil.	
CHAPTER V— <i>Cold Weather Operation</i>	40
PREPARING FOR COLD WEATHER—Anti-freezing solutions—Capacity of cool- ing system—Winter lubrication—Storage battery—Gasoline system—STARTING THE ENGINE—Carburetor enriching button—Priming the carburetor—Position of throttle hand lever—Position of spark control lever—Use of starter—Use of accelerator before engine is warm.	
CHAPTER VI— <i>General Care</i>	45
Storage battery—Cooling system—Gasoline filter—Temporary brake adjustment— BODY—Care of finish—Care of the top—Cleaning upholstery—Door Hardware.	
CHAPTER VII— <i>Storing Car</i>	50
Engine—Storage battery—Tires—Body and top—Taking car out of storage.	
CHAPTER VIII— <i>Specifications and License Data</i>	53

CHAPTER I

Cadillac Service

THE owner of a Cadillac car has purchased not simply a fine piece of machinery, ingeniously designed and carefully built—he has purchased a pleasant and dependable mode of transportation. The car itself is only one factor in securing this transportation—the other factor is Cadillac Service, which is built upon *a standard policy, clearly defined to the car owner and guaranteeing him efficient service everywhere at standard prices under factory regulation.*

Cadillac-La Salle Service Stations

Cadillac Service extends wherever Cadillac and La Salle cars are sold. Service stations conducted by Cadillac distributors and dealers are designated as "Authorized Cadillac-La Salle Service Stations" and are identified by the exclusive sign illustrated on the cover of this manual. Wherever this sign is displayed, the owner will find an organization prepared to service Cadillac cars. This means proper equipment, factory trained personnel, a stock of genuine replacement parts and standardized policies and methods.

The car owner's first and most frequent contact with Cadillac Service will naturally be in the service station of the distributor or dealer who sold him the car and who therefore has the greatest interest at stake in assuring his satisfaction. Nevertheless, he may feel perfectly free to use his car for extended travel without depriving himself of the service benefits to which he is entitled at his local service station. He will find other Authorized Cadillac-La Salle Service Stations able and willing to render the same service.

Service Card

As a means of introduction at other Authorized Cadillac-La Salle Service Stations, every purchaser of a Cadillac car is given credentials in the form of a Service Card. This card is mailed to him by the Cadillac factory immediately after the delivery of the car is reported by

the distributor or dealer. It is supplied in a celluloid case, and is intended to be carried in a holder provided on the rear face of the dash.

Upon presentation of this Service Card to any Authorized Cadillac-La Salle Service Station, the car owner is entitled to the following uniform standard service:

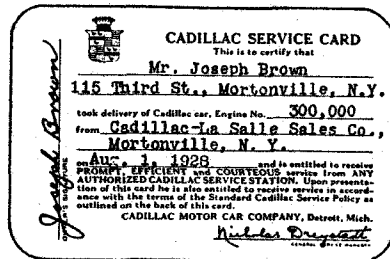

Figure 1. The Service Card, when properly signed, identifies a Cadillac owner at any authorized Cadillac-La Salle service station.

to be defective in material or workmanship within one year after the delivery date, provided the mileage of the car does not exceed 12,000 and that the replacement was not made necessary by accident, abuse or neglect. This includes material and labor.

The Service Card is not transferable, and the no-charge service set forth above is effective only while the car is in the hands of its original owner.

Service Charges

Service work other than that described above is performed by Authorized Cadillac-La Salle Service Stations on a flat-rate basis. When a car enters the service station, it is immediately inspected by a tester, who then quotes the owner an exact price for the work he finds necessary. The owner authorizes the work at this price, and when he receives his bill, this is the price he pays.

Charges prevailing at Authorized Cadillac-La Salle Service Stations are based on standard schedules furnished by the Cadillac Motor Car Company. These schedules call for methods and tools approved by the same engineers who designed and built the car, assuring the highest quality of work at the lowest possible price. Standard Price Schedules are open to inspection by owners at any Authorized Cadillac-La Salle Service Station.

1. All adjustments free of all charges that may be required within 90 days after the original delivery date (as shown on the card), provided the mileage of the car does not exceed 3000 and the adjustments are not made necessary by accident, abuse or neglect. This includes everything except lubrication, washing and storing.

2. Free replacement of any part which has proved to the Cadillac Motor Car Company's satisfaction

Repair Parts

Genuine Cadillac parts, manufactured to the same rigid specifications as the parts entering into the original assembly of the car, are carried in stock by Authorized Cadillac-La Salle Service Stations. They are sold at uniform prices throughout the United States, and are not subject to the addition of handling, excise or other supplementary charges. Printed price lists, published by the Cadillac Motor Car Company, are open to inspection by owners at any authorized Cadillac distributor's or dealer's establishment.

The Owner's Obligation

All of these service facilities are placed at the disposal of the Cadillac owner, in order that his car may be a continuous source of satisfaction and utility. This result cannot be guaranteed, however, unless the owner fulfills certain definite obligations himself, as follows:

1. To drive the car at moderate speeds for the first 500 miles.
2. To operate the car in accordance with the instructions contained in this manual.
3. To check the engine oil level every 100 to 150 miles, and add oil as often as necessary to keep the indicator at "full."
4. To check the tire pressure at least every week, and keep it up to the recommended pressure—45 pounds in front and 40 pounds in rear—on cars driven at high speeds, 50 pounds in front.
5. To add distilled water to the storage battery every 1000 miles, and in warm weather every 500 miles, or at least every two weeks.
6. To lubricate the car every 1000 miles, in accordance with the lubrication schedule on page 34.
7. To take the car to an Authorized Service Station for inspection every 1000 miles, or at least once a month.

Lubrication

The first five items above are details which do not necessarily warrant a visit to the service station. For lubrication, however, the owner is urged to patronize Authorized Cadillac-La Salle Service Stations, because they are prepared to furnish this service in a manner that cannot be duplicated elsewhere. Only approved lubricants are used, the specifications of which have been worked out by Cadillac engineers to give the

best possible results. Workmen who specialize on Cadillac cars know exactly where lubrication points are located and how much lubricant to apply. The charge for this lubrication service is less than half a cent a mile, which includes the cost of the lubricant.

Inspection

Preventive service is a fundamental principle of Cadillac Service. "Preventive service" is the practice of inspecting the car at regular intervals and making those adjustments that need attention before the need becomes an emergency. Inspections should be made every 1000 miles, in order to insure transportation satisfaction. Authorized Cadillac-La Salle Service Stations will make such inspections without charge, provided no dismantling of units is necessary.

The Cadillac owner is urged to take full advantage of this, not only while the car is new, but throughout its entire life.

Preventive service, rendered every 1,000 miles or once a month by an Authorized Cadillac-La Salle Service Station, is the surest guarantee of long life and complete motoring satisfaction at the least possible expense.

CHAPTER II

Operation

ONE of the first things the driver of a new car should do is to familiarize himself with the various controls described in the following chapter.

Locks

Each car is equipped with two each of two different keys, one for the combination ignition switch and transmission lock, the door lock and the tire carrier; and the other for the battery and tool box and the package compartments. The ignition key can be identified by its hexagonal end, while the package compartment key is oval.

The lock number is stamped on each key but not upon the face of the lock. The owner should make a record of the key numbers as soon as he takes delivery of his car, so that in the event both keys are lost, a duplicate key can easily be obtained from a Cadillac distributor or dealer.

Ignition Switch Lock

The lock at the lower right-hand side of the instrument panel controls both the ignition switch and the transmission lock. To unlock the car, insert the key and turn to the right. The cylinder of the lock will then slide out about half an inch, turning on the ignition and unlocking the transmission by means of a cable connection to the shifter shafts. To shut off the ignition and lock the transmission, simply push the lock cylinder all the way in. The car can be locked when the transmission is in neutral or in reverse. Do not attempt to shut off the ignition when the transmission is in any forward gear. Be sure to **remove the key** before leaving the car.

Gasoline Gauge

The gasoline gauge, marked "Fuel," is the small dial just to the left of the speedometer (Fig. 3). This gauge indicates in gallons the quantity of fuel in the tank at the rear of the car, and is operated electrically. To read from the gauge the quantity of fuel in the tank, the ignition must be switched on.

When the ignition is switched off, the gauge hand may come to rest anywhere on the gauge. It does not usually return to zero, nor does it

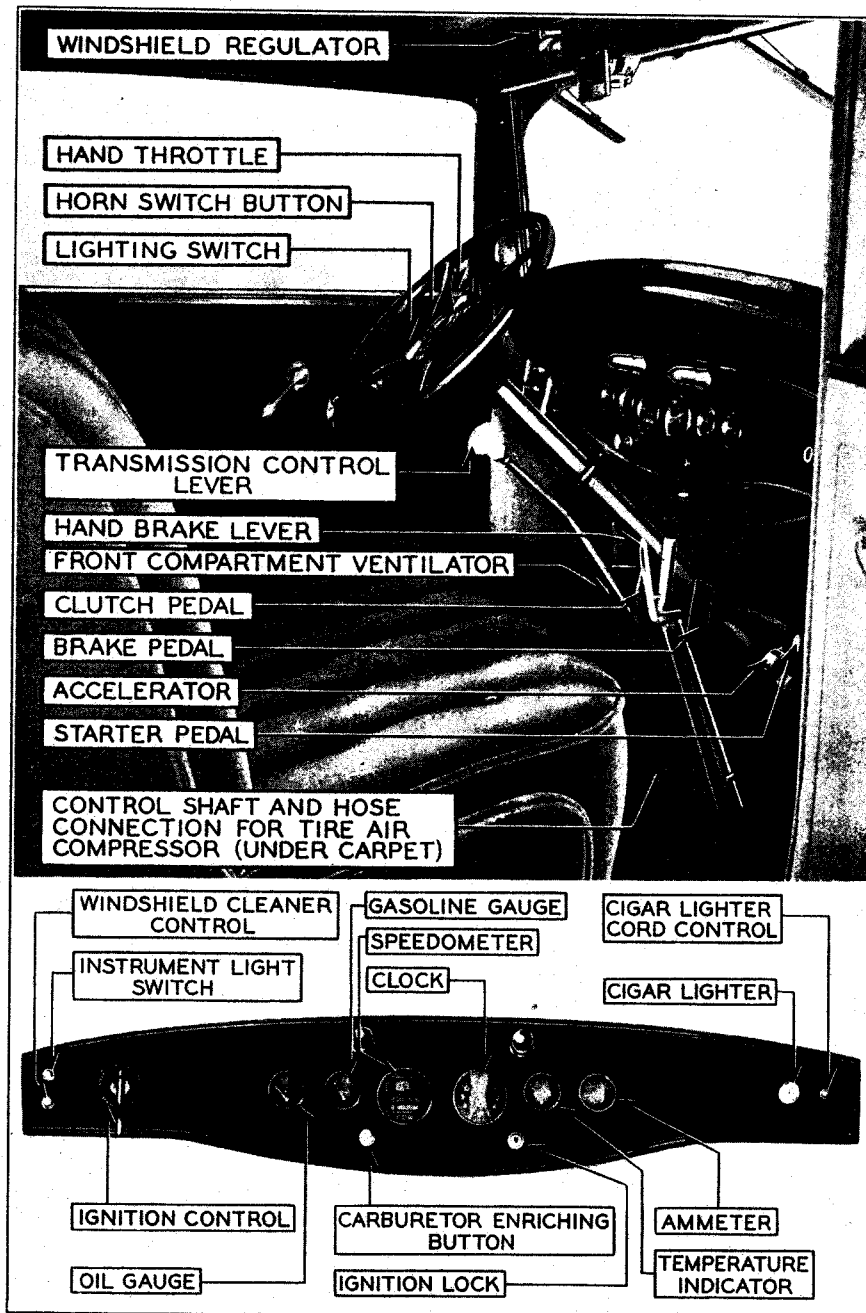

Figure 2. The new driver should familiarize himself with the instruments and controls before attempting to drive.

(10)

ordinarily stay in the position it had before the ignition was switched off. At such times, therefore, the reading of the gauge is not a true reading. A true reading is given only when the ignition is switched on.

As filling station rules forbid running the engine while the gasoline tank is being filled, on such occasions the ignition should be switched off until the engine stops and then switched on again, and left on while the tank is being filled.

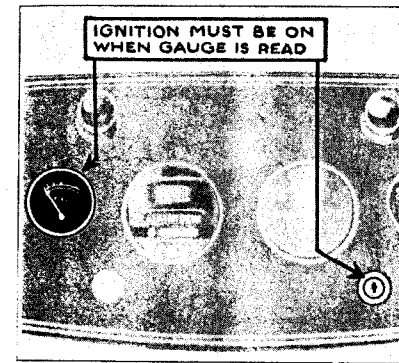

Figure 3. The gasoline gauge is operated electrically by current from the ignition circuit.

If the fuel supply should give out on the road, so that the vacuum tank on the dash becomes empty, it will be necessary after refilling the gasoline tank to prime the vacuum tank. To do this, close the throttle and hold the starter pedal down for 20 to 30 seconds. *The throttle must be closed while this is done.*

Temperature Indicator

The small gauge at the right of the clock (Fig. 4) is a thermometer for indicating the temperature of the engine, and takes the place of a temperature indicator on the radiator. The bulb end of the thermometer is inserted in the water jacket at the rear end of the right-hand cylinder head, and is connected by a small tube to the dial on the instrument board.

The normal engine temperature after the engine becomes warm is 160° to 190° .

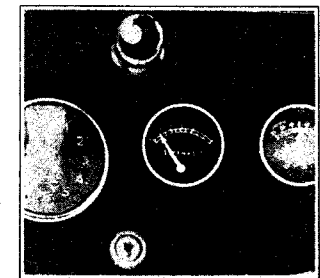

Figure 4. The temperature of the water in the cylinders should range from 160° to 190° .

Throttle Control

The power and speed of the engine are controlled by opening and closing a throttle valve in the carburetor. This throttle is operated both by a hand lever and a foot pedal.

The foot pedal, or accelerator, is at the right of the brake pedal (Fig. 2). The hand control is the upper lever above the steering wheel. Both controls operate the same throttle; the hand lever, however, remains in the

position to which it is moved, whereas the accelerator must be held down to keep the throttle open.

The normal position of the hand lever for driving the car is all the way up (at "Close"). In this position the throttle of the carburetor is open just enough to permit the engine to run at idling speed after it is warm. For starting, however, the lever should be moved approximately one-fourth the way down, and should be left in this position until the engine is warm enough to permit the lever to be returned to the idling position without stalling the engine. (Also see Chapter on "Cold Weather Operation.")

Ignition Control

Correct timing of the ignition in relation to the positions of the pistons is controlled automatically by the timer-distributor which provides for all ordinary advancing and retarding of the spark.

A hand control is also provided, however, for further advancing or retarding of the spark as occasion requires. The hand control is the lever on the instrument board in front of the steering column. The lever has three positions, "Starting," "Driving" and "Retard." When starting the engine *in cold weather*, the lever should be moved to the "Starting" position, which is **full advance**. With the lever in this position the engine will start more easily and will operate better while warming up.

When starting the engine in mild or warm weather, it is not necessary to turn the lever to the "Starting" position. The lever can then be left at the correct "Driving" position for the fuel being used.

After the engine has become warm, the lever should be moved to a position in the "Driving" range. The correct position of the lever in the "Driving" range will then depend on the fuel used. Cadillac cars are equipped with what are known as high compression cylinder heads. These heads enable the engine to develop more power when used with anti-knock fuel.

The high-compression cylinder heads do not prevent the use of regular fuel, but when regular fuel is used the spark lever must be retarded more than is necessary with anti-knock fuel. The spark should be retarded just to the point where the engine "pings" slightly on rapid acceleration. This slight amount of spark knock is absolutely harmless to the engine and is an indication to the driver that the spark is set at the point that will give maximum power and economy.

Carbon deposit, which accumulates with use in all engines, also causes spark knock and in time may require setting back the spark. Regardless of the kind of fuel used or the presence of carbon, the correct setting of the

spark control at any time is at the point where the engine "pings" slightly on rapid acceleration.

CAUTION—If the engine is being cranked by hand the spark should always be fully retarded—not moved to "Starting."

Carburetor Enriching Control

The button at the left of the instrument panel (Fig. 5) controls a device on the carburetor for temporarily enriching the fuel mixture supplied to the engine. When starting the engine, it is necessary to have the proportion of liquid gasoline in the fuel mixture greater than at other times, because in a cold mixture only a part of the gasoline is vaporized. Pulling out the enriching button increases the proportion of liquid gasoline to air, the normal proportions being restored when the button is released and permitted to return to its original position.

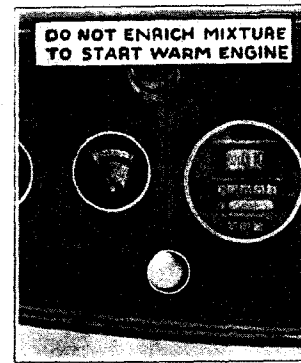

Figure 5. The carburetor enriching control does not prime the carburetor. To have any effect, it must be held out while the starter is cranking the engine.

Correct use of the enriching control not only is essential to quick starting of the engine, but also has an important effect on the life of the engine. The enriching button must be pulled out far enough in starting to provide an explosive mixture quickly so that the battery is not unnecessarily discharged by useless cranking. The button must also be held out far enough during the warming-up period so that the engine will run without missing and "popping back."

On the other hand, it should not be pulled out any further or held out any longer than is necessary to accomplish these results, because some of the excess liquid gasoline in the enriched mixture does not burn and washes off the oil on the cylinder walls, interfering with proper lubrication of the pistons.

If the engine still retains heat from previous running, the enriching control should not be used without first attempting to start the engine on the normal mixture. If the enriching button is pulled out for starting a hot engine, the mixture may be made so rich that starting will be impossible.

The enriching button is not a priming device. It has no effect whatever on the fuel or the fuel mixture unless the engine is being cranked or is run-

ning under its own power. To have any effect, the button must be pulled out and held partly out during the cranking operation.

Carburetor Heat Control

The flow of exhaust gases through the jacket of the intake header, by which the fuel mixture from the carburetor is heated, is controlled by an automatic valve at the front end of the left-hand exhaust manifold. This valve is so designed that it keeps the intake header at the proper temperature for the most efficient running at all engine speeds, so that a hand control lever is not necessary.

Starter Pedal

The starter pedal is at the right of the accelerator (Fig. 2). Pushing this pedal forward brings into action the electric motor that cranks the engine for starting. Do not push the starter pedal when the engine is running.

The starter pedal is only one of the controls that must be manipulated to start the engine. Unless there is an explosive mixture in the cylinders and a spark to ignite it, it is useless to crank the engine. The starter pedal should not be operated, therefore, until the necessary preliminary steps have been taken. The following, in their proper order, are the various steps that must be performed to start the engine.

1. Make sure that the transmission control lever is in neutral.
2. Place the throttle lever about one-fourth the way down from the idling position.
3. In cold weather move the ignition control lever all the way to "Starting."
4. Switch on the ignition.
5. Unless the engine is still warm, pull back the carburetor enriching button and hold it back. If the engine is still warm, do not pull back the enriching button unless the engine fails to start on the normal mixture.
6. Push the starter pedal forward and hold it until the engine starts. Release it immediately as soon as the engine starts. (See below for probable causes for the engine failing to start.)
7. Let the carburetor enriching button partly in as soon as the engine starts, and all the way in as soon as the engine is warm enough to permit it.
8. Note whether pressure is indicated on the oil pressure gauge and stop the engine at once if no pressure is indicated.
9. Move the throttle lever up to the idling position as soon as the engine is warm enough to permit it.
10. If the spark control was moved to "Starting" or "Retard" move it to the best position in the "Driving" range.

In cold weather, disengage the clutch before pressing down the starter pedal, and hold it down during the cranking operation. This relieves the starter of the necessity of turning the transmission gears which are immersed in lubricant. The additional load is small in warm weather when the lubricant is thin, but in cold weather the power required to turn the gears through the thickened lubricant adds unnecessarily to the demand upon the battery.

What To Do If the Engine Fails to Start

If the engine fails to start after being cranked for a few seconds, release the starter pedal and investigate the following possible causes:

The ignition may be switched off.

There may be no gasoline in the tank in the rear of the car.

There may be no gasoline in the vacuum tank on the dash. If the vacuum tank should be empty, prime it by closing the throttle, and with the ignition switched off, holding the starter pedal down for 20 to 30 seconds. The throttle must be closed while this is done. Then open the throttle, switch on the ignition, and try again to start the engine in the usual manner.

The carburetor may be flooded by unnecessary use of the enriching device when the engine is warm. To get rid of this surplus gasoline in the carburetor, open the throttle wide, and, with the ignition switched off, hold the starter pedal down for 10 to 15 seconds. Then return the throttle lever to the usual position for starting, switch on the ignition and try again to start the engine.

Oil Pressure Gauge

The small dial at the extreme left-hand end of the instrument panel (Fig. 6) is the oil pressure gauge. This gauge does not indicate the quantity of oil in the engine. It indicates only the pressure under which the oil is forced to the engine bearings.

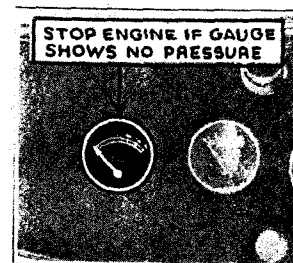

Figure 6. The oil pressure gauge does not show how much oil is in the engine—it shows pressure only. The pressure when the engine is idling should be 7 to 10 pounds.

When the engine is not running, the pointer on the oil pressure gauge should remain at zero, but as soon as the engine is started and as long as it runs, the gauge should show pressure. If the gauge does not show pressure when the engine is running, stop the engine at once and determine the cause. Serious damage may be done if the engine is run without oil pressure.

The amount of pressure indicated by the gauge depends upon the speed of the engine and the viscosity of the oil. At idling speed with fresh oil of the correct viscosity, the oil pressure after the engine is warm should be 7 to 10 lbs. Before the engine is warm, the pressure will be higher. After the oil has become thin the pressure will be lower. These are normal variations from the standard and do not indicate need for attention.

Clutch Pedal

The clutch pedal is the left-hand pedal. When this pedal is in its normal or released position, the clutch is engaged. The flywheel of the engine is then coupled to the transmission. When the clutch pedal is pushed down, the clutch is disengaged, and the flywheel, if the engine is running, revolves independently of the transmission.

The clutch has two uses: First, to enable the car to be started gradually and without jerk or jar; second, to permit shifting of the transmission gears. The operation of the clutch pedal is discussed below in connection with the transmission control. Further comment is unnecessary at this point, except the following suggestions to the driver:

Do not drive with the foot resting on the clutch pedal. The Cadillac clutch operates so easily that even the weight of the driver's foot may unintentionally cause the clutch to slip.

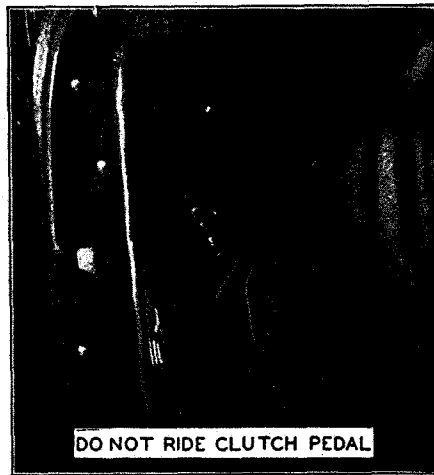

Figure 7. A good driver uses the clutch pedal only when shifting gears or about to stop.

Do not form the practice of disengaging the clutch whenever the brakes are applied. Most occasions for use of the brakes require only slowing down without stopping or even shifting gears. A skilled driver will not touch the clutch pedal until the car is just about to stop or until he is about to shift to a lower gear. It is a mistaken idea that applying the brakes with the clutch engaged is more severe on the brake lining. The opposite is actually the case, proof of which is in the fact that in coasting down grades, the resistance of the engine is used to assist the brakes in controlling the car speed.

It will be observed in operating the clutch pedal that the pedal offers almost no resistance until it has been moved about one inch. It is at this point that it actually begins to disengage the clutch. It is important that the pedal have this "lost motion." If the full pressure of the clutch springs is felt just as soon as the pedal is moved, the control rod should be readjusted. Failure to make this adjustment will result in the clutch slipping.

Transmission Control

The operation of the Cadillac Syncro-mesh transmission is, in general, the same as the operation of the conventional selective sliding-gear type of transmission. The positions of the control lever for the various speed combinations are the same and the directions in which the control lever is moved are the same. It is also necessary to disengage the clutch before moving the control lever, the same as with the conventional transmission.

The only difference is in the manner of moving the control lever. With the conventional transmission, it is customary when shifting to a higher gear to hesitate momentarily in neutral and then move the lever quickly to its new position.

With the Cadillac Syncro-mesh transmission there is no necessity either for the hesitation in neutral or for the rapid movement of the lever during the latter part of the shift. Instead, the movement of the control lever should be one smooth, continuous movement.

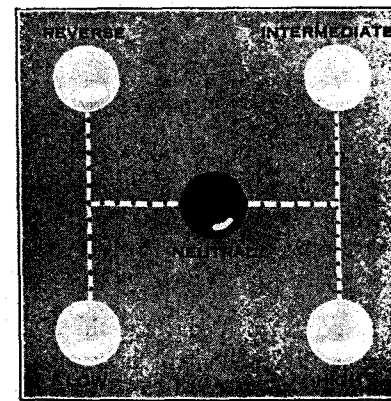

Figure 8. The positions of the control lever are the same as for the conventional type of transmission.

Without giving a detailed explanation of the synchronizing mechanism, it may be said that its purpose is to secure noiseless shifting of the control mechanism by automatically synchronizing (or equalizing) the speeds of the two members which are to be coupled together, before the shift is made.

This synchronizing effect is brought about by a pair of friction clutches of simple cone-type, which are actuated by the control lever through a cam mechanism. As the control lever leaves the neutral position, it engages one or the other of these clutches just long enough to synchronize the two members, so that when the final movement of the control lever

is made, the teeth which interlock to take the drive are traveling at exactly the same rate of speed.

The synchronizing principle applies to all shifts into intermediate or high; in other words, to the following shifts:

Low to intermediate

Intermediate to high

High to Intermediate

There is no synchronizing mechanism for low or reverse gears because shifts into these gears are usually made when the car is standing still. When shifting from neutral to low or reverse, therefore, it may be necessary to await an instant after disengaging the clutch, to give the gears a chance to stop "spinning." Do not attempt to shift from intermediate to low unless the car is standing still or moving very slowly.

If, when descending a grade at high speed, it becomes desirable to shift from high to intermediate, in order to use the engine as a brake, re-engage the clutch slowly after making the shift. This will bring the engine up to speed gradually and avoid the sudden load that would otherwise be imposed upon the clutch.

The ease and certainty with which a noiseless shift can be made with the new transmission, may tempt some drivers to perform "stunts" for which it is not intended. The synchronizing principle makes it possible for the driver to make use of intermediate speed at any time that it is an advantage to do so, without having to worry whether he will get "into gear" successfully. There is no advantage to be gained, however, in using intermediate at speeds above 30 miles per hour, and any attempt to shift at higher speeds should be regarded as abuse.

Coasting

To coast on the level, simply release the accelerator pedal and disengage the clutch. If coasting to a stop, the transmission control may also be shifted to neutral and the clutch re-engaged.

In coasting down grades, however, it is recommended that the transmission be left in gear and the clutch engaged. With the throttle in the idling position, the car is thus made to drive the engine, the resistance of which assists the brakes and saves wear on the brake lining. It must be remembered that the brakes are subjected to much more severe use on grades than on the level, because gravity acts continuously, whereas on the level, the brakes need absorb only the momentum of the car. Even on slight grades, coasting with the transmission in neutral or the clutch disengaged is not

advisable. On any grade steep enough to warrant coasting, it is worth while to save the brakes as much as possible by utilizing the braking effect of the engine.

Ordinarily, the resistance offered by the engine when the transmission is in high is sufficient to control the speed of the car, supplemented by moderate use of the brakes. On steep grades, however, the transmission control should be shifted to intermediate.

Do not switch off the ignition when coasting with the car driving the engine. Contrary to a common impression, this does not appreciably increase the resistance, and is likely to cause damage to the engine. Even with the throttle closed, some fuel is admitted to the cylinders, and if this is not burned, it condenses on the cylinder walls and washes off the oil by which the pistons are lubricated.

Brakes

The foot brakes, operated by the right-hand pedal, are internal brakes of the shoe type, applied on all four wheels through a mechanical linkage.

The front wheel brakes are designed so that, if applied while the steering wheel is turned to the right or left, only the brake on the inside wheel is effective and the brake on the outer wheel is released, leaving it free to rotate. It is thus impossible to lock both front wheels, even on slippery pavement, unless the car is moving straight ahead.

Gradual application of the brakes will provide sufficient stopping power and will result in less strain on the mechanism, so the brakes should not be applied suddenly except in an emergency. This is particularly true in crowded traffic, for a vehicle following may not have such efficient brakes.

When applying the brakes on wet asphalt streets or slippery roads, do not disengage the clutch until the car is almost stopped. Do not attempt sudden stops. Cadillac four-wheel brakes minimize the possibility of skidding under these conditions, but their effectiveness should not induce anyone to drive less carefully.

As the brake lining wears, the pedal must be pushed farther down to apply the brakes. Do not wait until the pedal goes all the way to the floor board before having the brakes readjusted. Readjustment is recommended as soon as the pedal must be pushed down to within one inch of the floor board. A temporary adjustment of the brakes is explained on page 53.

For parking, the brakes are operated by the hand lever at the right of the transmission control lever.

Speedometer

The lower dial of the speedometer, which is for recording "trip" mileage, can be reset to zero by pushing up and turning the knurled stem back of the instrument board.

Across the speedometer cover glass and below the total mileage dial is a strip of black celluloid on which are two white spaces. These spaces are for the lubrication notice described on page 39 in connection with the lubrication schedule. Use this notice in accordance with the schedule.

An automobile repairman should never be permitted to attempt to adjust or repair the speedometer head or to replace the glass. This work can be done only by men experienced in speedometer work and only with special machinery and tools. If the speedometer head is removed, handle it as carefully as a fine watch. The speedometer head may easily be damaged by rough handling.

Ammeter

The dial at the extreme right of the instrument panel (Fig. 9) is the ammeter, which measures the electric current flowing to or from the battery at all times, except when the starter is cranking the engine. When current is flowing from the battery, the ammeter shows a reading on the side marked "Discharge;" when current is flowing to the battery, the ammeter is on the "Charge" side.

The ammeter should indicate on the "Charge" side most of the time. Otherwise, more current will be taken out of the battery than is put into it and the battery will eventually become fully discharged. When the engine is not running, the ammeter will indicate a current on the discharge side, depending in amount upon the number of lights in use. The rate of charge or discharge when the engine is running depends upon the speed of the engine and the number of lights in use, and is equal in amount to the difference between the current generated and the current used by the lights, horn, ignition and other electrical devices.

Ordinarily, when no lights are in use, the ammeter should show "Charge" as soon as the car is running ten or twelve miles per hour in high gear. If the ammeter should show "Discharge" with all lights off, either when the engine is not running or when the car is

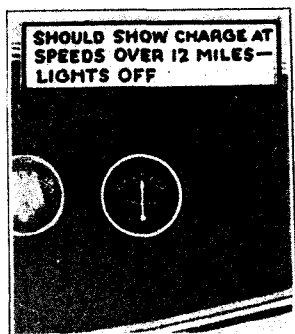

Figure 9. The ammeter indicates the amount of electrical current flowing to or from the battery.

running more than twelve miles per hour, the cause should be investigated.

running more than twelve miles per hour, the cause should be investigated.

Lighting Switch

The lighting switch control is at the upper end of the steering column in the center of the steering wheel. The lever has three positions besides the "off" position, which is the straight down position. Turning the lever to the left turns on the parking lamps on the fenders and the rear lamp. The first position of the lever when turned to the right switches on the headlamp lower beams and the rear lamp, while the second position to the right switches on the headlamp upper beams and the rear lamp.

The headlamp bulbs have two filaments, one above the other, instead of the customary single filament. Both filaments are of the same candle-power (21), but because they are located in different positions with respect to the reflector, the beam of light from one filament is projected at a different angle from the other. When the switch lever is at the upper position to the right, one set of filaments is lighted and the beams are projected straight ahead, illuminating the road at a distance. When the lever is at the lower position, the other filaments are lighted and the beams are projected down at an angle, illuminating more brightly the road directly in front of the car.

The practice to be followed by the driver in using this double-beam feature of the headlamps will depend upon local regulations. In general, it is expected that the upper beams will be used except on the following occasions: When passing a vehicle approaching from the opposite direction, when rounding a sharp curve and when topping the crest of a hill. On these occasions, and at other times when illumination is desired directly in front of the car, the lower beams should be used.

The instrument lamps are controlled by a separate switch at the left-hand end of the instrument board.

The lamp bulbs that are used are as follows:

Lamp	Voltage	Candle-Power
Headlamps	6-8	21 (Two-Filament) Mazda No. 1110
Stop lamps (2)	6-8	15
Parking lamps	6-8	3
Instrument lamps (2)	6-8	
Rear lamps (2)	6-8	
Closed car lamps	6-8	

Danger of Running Engine in Closed Garage

Every person having to do with the operation or care of a motor car should be warned of the danger that attends running the engine while the car is in a small closed garage.

Carbon monoxide, a deadly poisonous gas, is present in the exhaust of all internal combustion engines. Most people are already familiar with carbon monoxide in the form of illuminating gas, or in the gas produced by furnaces and stoves when insufficient air is supplied to give complete combustion. But illuminating gas and coal gas have unpleasant odor, which serves as a warning, whereas carbon monoxide, as produced in the internal combustion engine, is colorless, tasteless, and almost odorless, so that the victim may be overcome before he is aware of the danger. When the engine exhausts into the open air, the carbon monoxide is so diluted that it has no effect. It is when the engine is run for a time in a closed room that the proportion of carbon monoxide in the air may increase to the point at which continued breathing of it would be fatal. The United States Public Health Service advises that the average automobile engine warming up in a single-car garage will give off enough carbon monoxide in three minutes to endanger life.

Proper precaution must be taken in cold weather when the natural tendency is to keep the garage doors and windows closed. The practice of letting the engine warm up in a closed garage before opening the doors is unsafe. The risk is made greater by the fact that the enriching of the mixture by manipulation of the carburetor enriching device increases the amount of carbon monoxide formed.

CHAPTER III

EQUIPMENT

THE controls and instruments used in driving have already been described. In addition to these, the car is equipped with various devices which are for the convenience and comfort of the occupants, and are used only as occasion demands. It is suggested that the driver anticipate his use of such equipment by becoming familiar at once with the directions contained in this chapter.

Windshield and Ventilation

Cadillac closed cars are equipped with a one-piece windshield, which can be moved up and down. Movement of the glass is controlled by a handle above the windshield. To raise the glass, the handle should be turned clockwise, and to lower the glass, the handle should be turned counter-clockwise.

For ventilation under the cowl, the windshield should be raised not more than one inch, so that the lower edge of the glass is still below the ledge over the instrument board. With the windshield in this position, air is deflected into the driving compartment through an opening in the cowl, just forward of the instrument board. If desired, the windshield can be raised above the level of the ledge over the instrument board, and air will then enter directly into the car. In this position, however, less air will be forced down under the cowl. (Fig. 10.)

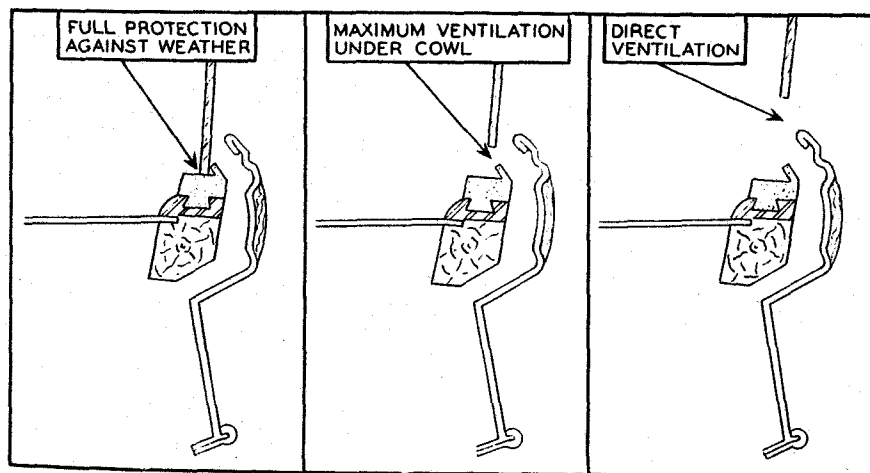

Figure 10. The closed car windshield has three positions: the position shown in the center is best for warm weather.

Cowl ventilators are also provided on the closed cars to supplement the ventilation provided by the windshield. These ventilators are at the sides of the cowl compartment and open toward the rear, serving as outlets for the air entering under the windshield.

Windshield Cleaner

The windshield cleaner consists of two wiper blades, operated by the suction or vacuum in the passages between the carburetor and the engine. The cleaner is controlled by the lower of the two buttons at the extreme left-hand end of the instrument board. When the button is turned clockwise as far as it will go the cleaner is shut off. To start the cleaner, turn the button counter-clockwise.

Adjustable Seat

The driver's seat is adjustable on all Cadillac cars, except those that are intended to be chauffeur-driven. On open cars, the back of the seat can be moved forward or backward as desired. This adjustment is controlled by the handle on the top of the back of the seat. To move the seat forward, turn the handle clockwise; to move it backward, turn the handle counter-clockwise.

On closed cars, the entire front seat can be moved forward or backward. This adjustment is controlled by a handle on the center of the seat, about three inches above the floorboards. To move the seat forward, turn the handle clockwise; to move it backward, counter-clockwise. The handle must be turned one-half turn at a time.

As the front seat on the five-passenger coupe is divided, only the driver's half of the seat is adjustable. The handle for making the adjustment is on the side of the seat, otherwise the adjustment is the same.

Cigar Lighters and Inspection Lamp

The car is equipped with a combination cigar lighter and inspection lamp that makes use of a single reel with twelve feet of flexible cord attached to the back of the instrument board. The flexible cord ends in a bayonet type socket, to which may be attached either the inspection lamp or the heating element of the cigar lighter. The method of attachment is identical with that of an ordinary lamp bulb. Ordinarily the cigar lighter will be carried in place in the socket on the cord and the inspection lamp in a stationary socket provided on the front of dash, where it is useful to illuminate the engine. (The inspection lamp is packed with the tool equipment when the car is shipped.)

To use the cigar lighter, pull it out from the instrument board at least a foot, wait a few seconds for the heating element to heat and apply it to the cigar or cigarette. The current is automatically switched on as soon as ten or twelve inches of the cord have been unreel. To light a pipe, remove the nickel-plated shield by turning it slightly counter-clockwise and pulling it straight off.

To lock the cord in any desired position, pull out the button on the instrument board at the right of the cigar lighter (Fig. 2). This engages a ratchet which prevents the reel from rewinding. To rewind the cord, press the button back to its original position.

The inspection lamp socket on the dash has a double bayonet lock with two sets of slots. To install the lamp, simply insert it in the socket, press in, and turn it clockwise as soon as the pins on the lamp engage the first or outer sets of slots. In this position, the current is not switched on. To switch the current on, turn the lamp slightly counter-clockwise, press in, and turn it clockwise again, engaging the pins in the second or inner set of slots. To switch off the light, turn the lamp counter-clockwise and pull it out of the socket far enough to engage the first set of slots.

The smoking sets of Sedan models are equipped with a cordless cigar lighter that can be passed around. To use this lighter, depress the switch on the side of the lighter, hold it in place until the heating element gets red and lift the lighter out for use.

Tools

The tools comprising the standard equipment are listed below and are illustrated in Fig. 11. Items listed opposite Nos. 17, 18 and 19, are not illustrated.

- | | |
|----------------------------------|-----------------------|
| 1. Hammer | 11. Grease gun |
| 2. Monkey wrench | 12. Rim tool |
| 3. Large screw-driver | 13. Hub cap wrench |
| 4. Pliers | 14. Brace wrench |
| 5. Crescent adjustable wrench | 15. Jack handle |
| 6. Small screw-driver | 16. Jack |
| 7. Oil can | 17. Tool bag |
| 8. Spark plug wrench | 18. Lubrication chart |
| 9. Starting crank | 19. Operator's Manual |
| 10. Hose for tire air compressor | |

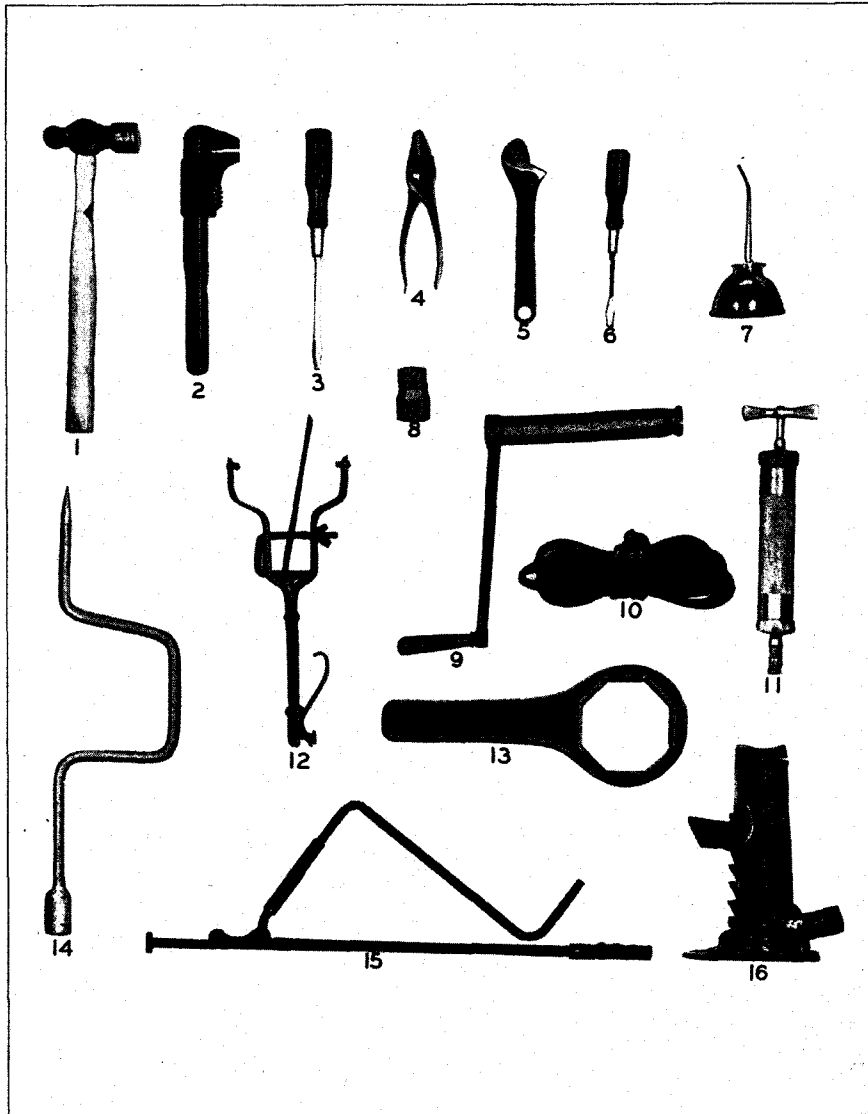

Figure 11. The standard tool equipment. See page 25 for the name and use of each tool.

Tool Compartment

The compartment for the tool equipment is between the left-hand running board and the frame, and is accessible upon opening a door in the left-hand dust shield. The lock on the tool box door is operated by the key for the package compartments, not by the ignition key.

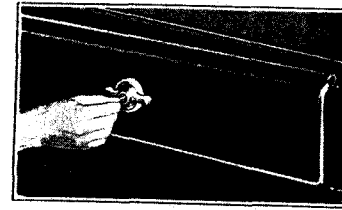

Figure 12a. The tool box door can be unlocked with the package compartment key.

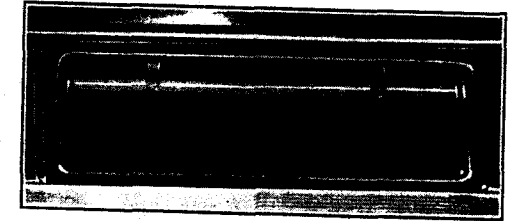

Figure 12b. A retaining rod holds the inner cover of the tool box in place.

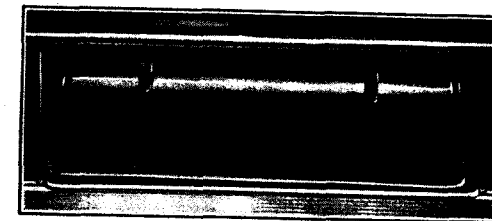

Figure 12c. The inner cover can be removed after the retaining rod is dropped down.

To reach the tools, proceed as follows: Insert the key and turn it clockwise until the lock barrel springs out. The handle can then be turned until the catches are released, permitting the door to be tilted out at the bottom and lifted out clear of the dust shield.

The tools are contained in an inner box, which is held in place by the rod shown in Fig. 12b. Force this rod out of the depressions in the handles on the cover of the box, and let the rod drop to the position shown in Fig. 12c. The cover of the box can then be removed by means of the two handles.

The door of the battery compartment operates in the same manner as the tool compartment.

Tires

Tire Valve Caps

The valve caps used with some makes of tires are a combination dust and valve cap. This type of cap can be removed and installed without screwing the cap the entire length of the threads on the valve stem.

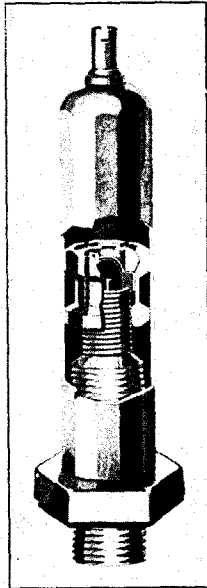

Figure 13. Tire valve cap.

To remove one of these valve caps, turn it two or three turns counterclockwise. This loosens the sliding nut inside the cap. (Fig. 13.) Next, pull the cap up as far as it will go. Then remove the cap by unscrewing it the rest of the way.

To install a valve cap, place the cap over the valve stem and turn it a few turns clockwise to engage the threads in the sliding nut. If the sliding nut is too far inside the cap to be reached by the valve stem, shake the nut down by tapping the bottom of the cap on some solid object. When the valve stem has been started in the sliding nut, push the cap down over the stem as far as it will go. Then turn the cap until it locks tightly.

Inflation Pressure

For normal driving, the front tires should be inflated to a pressure of 45 lbs. and the rear tires to 40 lbs. The inflation pressure should be checked at least weekly, and should never be permitted to drop more than 5 lbs.

On cars driven at high speeds, the front tires should be inflated to 50 lbs. This is important.

Tire Air Compressor

To use the tire air compressor with which the car is equipped, proceed as follows:

Turn back the left-hand side of the front carpet and lift the small oval-shaped cover which is in the floor, just to the left of the transmission con-

rol lever. Reach through the hole in the floor and remove the knurled cap from the connection on top of the compressor. Connect one end of the air hose (in the tool equipment) to this connection and at the other end of the hose to the valve of the tire to be inflated. Do not connect the hose to the tire first, if there is pressure in the tire.

The control shaft, by which the compressor driving gear is placed in mesh with the transmission gears, projects through a small hole in the floor, just in front of the large hole over the compressor. To start the compressor, if the engine is running, disengage the clutch and hold the pedal down until the transmission gears have ceased to revolve. Then, with a screw-driver, turn the slotted head of the compressor control shaft clockwise. If the engine is not running, simply turn the control shaft clockwise, without disengaging the clutch and then start the engine.

The compressor gives best results when the engine runs at a speed of approximately 1000 r.p.m., which is about three times the normal speed of the engine when idling. Do not race the engine in operating the compressor, or, for that matter, at any other time when it is not driving the car. Racing the engine beyond the recommended speed not only decreases the efficiency of the compressor, but is one of the worst forms of abuse. To stop the compressor, turn the control shaft counter-clockwise.

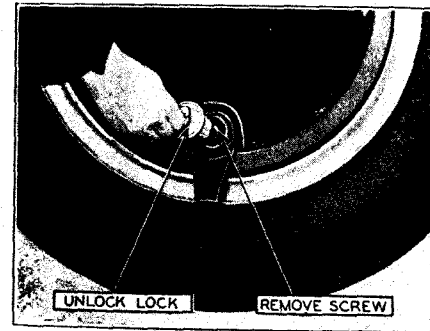

Figure 14. To remove the spare tire, unlock the lock, remove the screw and take off the clamp.

Do not turn the compressor control shaft to start the compressor when the engine is running and the clutch is engaged.

Tire Carrier

To remove the spare tire from the carrier, proceed as follows: Insert the key in the lock and turn it to the right.

Remove the lock, using the key as a handle.

Unscrew the clamping screw with the wrench furnished in the tool equipment.

Remove the rim clamp, taking care not to lose the clamping screw.

Remove the tire with rim, by pulling it out at the bottom and then lifting it off the carrier.

To place a tire and rim on the carrier, reverse the above order. After tightening the clamping screw, unlock the lock and put it into place.

Spare Wheel Carrier

To remove a spare wheel from the carrier, unlock the lock and take it out, using the key as a handle. Then unscrew the clamping screw underneath the lock, after which the large dust shield can be removed and the wheel taken off the carrier.

To reinstall a spare wheel, mount it on the carrier, place the large dust shield in position and tighten the clamping screw. Then snap the lock back into place.

These instructions apply both to spare wheel carriers on the rear of the car and to carriers in the front fender.

Truing Up Rim

If a rim on a wood wheel does not run true, it may be trued up in the following manner: Rotate the wheel slowly and mark the part that runs farthest out from the face of the wheel. Loosen slightly the nuts diametrically opposite the mark, and then tighten the nuts on the marked side. Test the wheel again, and if it still does not run true, repeat the operation.

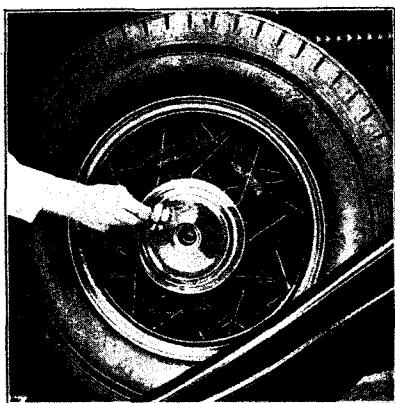
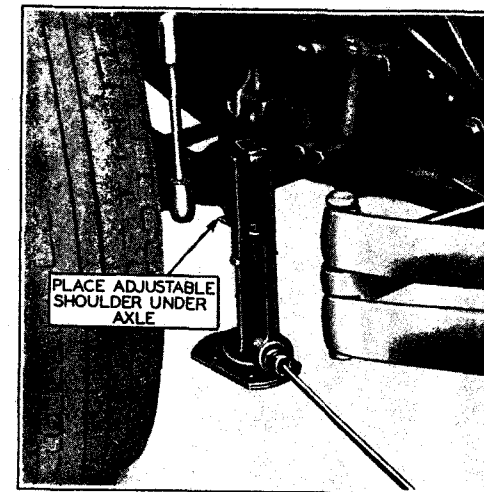

Figure 15. When spare tires are carried on the fenders, the lock must be removed after which the screw can be taken out and the wheel lifted from the carrier.

The illustrations in Figure 16 show how the adjustable shoulder should be placed under the axles.

Changing Tires

If an inflated tire is always carried on the spare rim or wheel, the driver will seldom or never have to disassemble a tire from the rim. In case of tire trouble, it is then merely necessary to remove the rim or wheel with the flat tire and then install the spare in its place. Illustrated directions for performing this work on standard wood and on wire wheels are given on pages 32 and 33. Disc and demountable wood wheels are changed in the same manner as wire wheels except that the hub caps should not be removed.



Tire Balancing Marks

The tires are balanced to offset the weight of the valve stem. If a tire is removed, it must be re-installed in its original position with respect to the rim; otherwise the tire and wheel will be unbalanced.

A small red square is accordingly branded in the rubber on the side of each tire. This mark must always be in line with the valve stem.

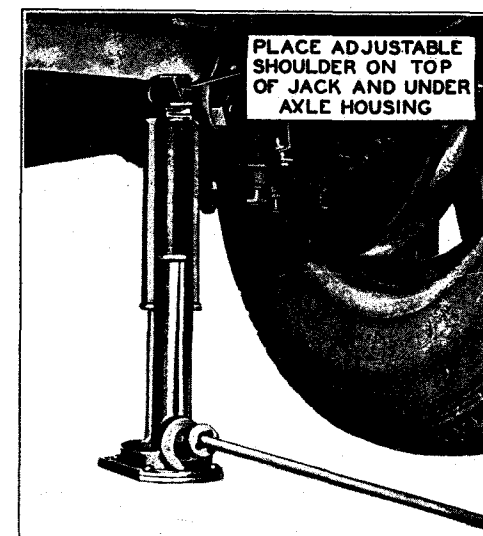

Figure 16. To jack up the car, it is necessary to have the jack in the proper position under the axle. The correct position for the front axle is shown above and for the rear axle, below.

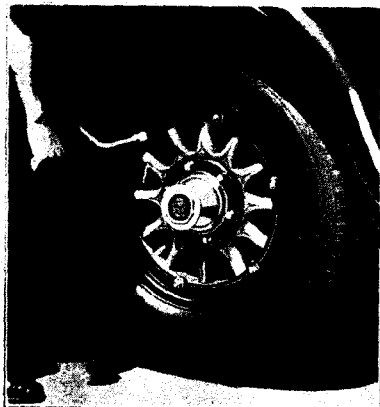

Figure 17a. Jack up the wheel until the tire clears the ground. Remove the dust cap and clamping nut from the valve stem. Remove the six rim clamps, unscrewing them with the brace wrench supplied in the tool kit.

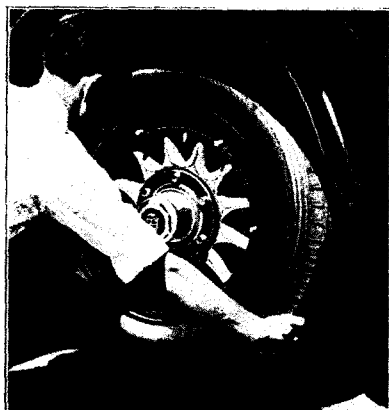

Figure 17b. Rotate the wheel until the valve stem is at the top, and pull the bottom of the rim away from the wheel.

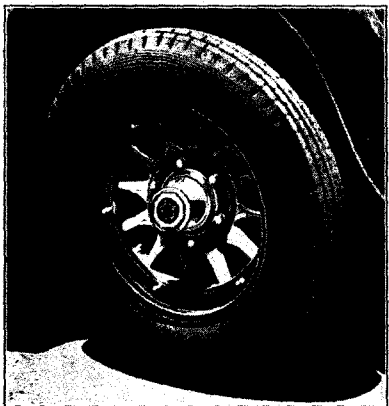

Figure 17c. Then rotate the wheel until the valve stem approaches the bottom, when the rim and tire will roll free from the wheel and can be removed without lifting.

To mount a rim, rotate the wheel until the hole for the valve stem is in the position shown in the last illustration. Insert the valve stem and rotate the wheel, which will carry the rim with it, until the valve stem is at the top. Then push the lower part of the rim into place. Install the rim clamps over the rim and turn the nuts partly down. Go over the nuts again and tighten them firmly. Install the valve stem clamping nut and the dust cap. Be sure the clamping nut is tight.

Figure 17. Changing rims (Standard wood wheels)

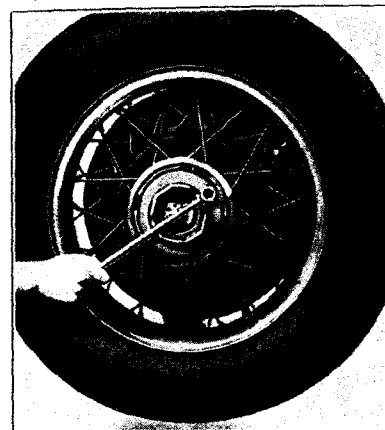

Figure 18a. Remove the hub cap with the wrench in the tool kit. Hub caps are marked with arrows showing the direction in which they screw on and off.

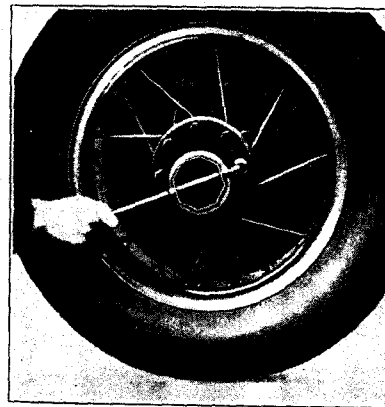

Figure 18b. Jack up the axle until the weight of the car is off of the wheel, but with the tire still dragging. Loosen the cap screws around the wheel hub by turning them in a counter-clockwise direction with the wrench. Then jack the wheel up further, remove the cap screws and take the wheel off of the hub.

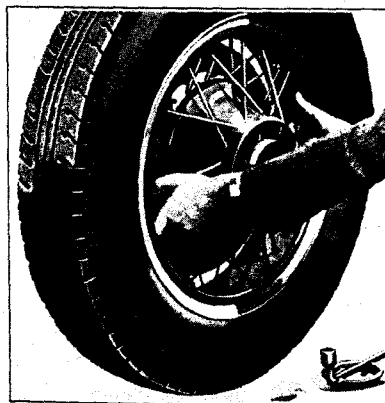

Figure 18c. To mount a wheel, simply set it up on the hub and start the cap screws by hand. Then tighten the screws with the wrench, but do not tighten them in rotation. After tightening one screw, tighten the screw directly opposite.

Figure 18. Changing Wire Wheels.



CADILLAC LUBRICATION SCHEDULE



OWNER'S NAME _____
 ADDRESS _____
 ENGINE NO. _____ DATE DELIVERED _____

Do not wait for schedule lubrications before adding engine oil. The oil level should be checked every 100 to 150 miles and oil added if the indicator ball is below "Full." This is especially important on cars driven at high speed.

LUBRICATION NOS. 6 AND 12
 LUBRICATION NOS. 3 AND 9
 LUBRICATION NOS. 2, 4, 8 AND 10
 LUBRICATION NOS. 1, 5, 7 AND 11

LUBRICANT	LUBRICATION NO. AND MILEAGE AT WHICH DUE											
	1000	2000	3000	4000	5000	6000	7000	8000	9000	10000	11000	12000
CHECK RADIATOR LEVEL	○	○	○	○	○	○	○	○	○	○	○	○
ADD ENGINE OIL AS NECESSARY	○	○	○	○	○	○	○	○	○	○	○	○
STARTER, GENERATOR AND DISTRIBUTOR OIL CUPS	○	○	○	○	○	○	○	○	○	○	○	○
BRAKE PINS AND CONNECTIONS	○	○	○	○	○	○	○	○	○	○	○	○
DOOR HARDWARE	○	○	○	○	○	○	○	○	○	○	○	○
GREASE GUN CONNECTIONS	○	○	○	○	○	○	○	○	○	○	○	○
WATER PUMP GREASE CUP	○	○	○	○	○	○	○	○	○	○	○	○
*ADD WATER TO STORAGE-BATTERY	○	○	○	○	○	○	○	○	○	○	○	○
CHECK TIRE INFLATION	○	○	○	○	○	○	○	○	○	○	○	○
DRAIN AND REPLACE ENGINE OIL	○	○	○	○	○	○	○	○	○	○	○	○
CLUTCH RELEASE BEARING	○	○	○	○	○	○	○	○	○	○	○	○
TRANSMISSION—ADD LUBRICANT	○	○	○	○	○	○	○	○	○	○	○	○
REAR AXLE—ADD LUBRICANT	○	○	○	○	○	○	○	○	○	○	○	○
STEERING GEAR—ADD LUBRICANT	○	○	○	○	○	○	○	○	○	○	○	○
TIMER DISTRIBUTOR CAM	○	○	○	○	○	○	○	○	○	○	○	○
FRONT BRAKE TRUNNIONS AND BRAKE CAM BEARINGS	○	○	○	○	○	○	○	○	○	○	○	○
WHEEL BEARINGS	○	○	○	○	○	○	○	○	○	○	○	○
SPEEDOMETER DRIVE SHAFT	○	○	○	○	○	○	○	○	○	○	○	○
**REFILL SHOCK ABSORBERS	○	○	○	○	○	○	○	○	○	○	○	○
**FLUSH COOLING SYSTEM	○	○	○	○	○	○	○	○	○	○	○	○
REPLACE OIL FILTER CARTRIDGE AND CLEAN OIL PAN AND SCREEN	○	○	○	○	○	○	○	○	○	○	○	○
												○

EVERY 12,000 MILES

THE FOLLOWING OPERATIONS CANNOT BE PLACED ON A MILEAGE BASIS AND ARE NOT INCLUDED IN THE ABOVE SCHEDULE:
 REMOVE OIL PAN AND CLEAN PAN AND SCREEN—ONCE A YEAR OR WHENEVER OIL FILTER IS CHANGED
 THIN REAR AXLE AND TRANSMISSION LUBRICANT AS REQUIRED FOR LOW TEMPERATURES
 DRAIN AND REPLACE REAR AXLE AND TRANSMISSION LUBRICANT—AT BEGINNING OF MILD WEATHER IN SPRING
 REMOVE SPRING COVERS ONCE A SEASON AND REPACK WITH PETROLEUM JELLY
 *IN SUMMER, INSPECT BATTERY EVERY 500 MILES OR AT LEAST EVERY 2 WEEKS.
 **RECOMMENDED BUT NOT INCLUDED IN LUBRICATIONS 6 AND 12.

RECORD ON OTHER SIDE

Figure 20. This is a fac-simile of the Cadillac Lubrication Schedule and Record Card. Provision is made on the back of the card for recording when and where the car is lubricated. A copy of this card can be obtained on request from Cadillac distributors and dealers.

CHAPTER IV

Lubrication

Lubrication Schedule

SYSTEMATIC lubrication, at regular mileage intervals, is the only kind that is effective. On page 36 is a complete lubrication schedule, which, if faithfully followed, will insure correct lubrication for each wearing surface of the Cadillac car.

The unit of the schedule is 12000 miles, which is divided into twelve 1000-mile intervals. Corresponding to these is a series of twelve consecutive groups of lubricating operations. When the car has traveled 1000 miles, the points enumerated under Lubrication No. 1 should receive attention. At 2000 miles, Lubrication No. 2 is due, and so on until at 12000 miles, Lubrication No. 12 should be performed. At 13000 miles, the schedule begins again with Lubrication No. 1.

It will be noticed from the schedule that there are actually only four different lubrication operations, but that they are numbered according to the various times that they come due.

Lubrication Notice

In order that the driver may be continually reminded of the mileage at which the next lubrication is due, the speedometer is provided with a lubrication notice. This consists of a strip of black celluloid (Fig. 19), which is placed across the speedometer cover glass below the total mileage dial and which has two white spaces, one for the lubrication number and one for the mileage at which it is due.

Whenever the car is lubricated on the schedule, the figures then on the celluloid should be erased and the next lubrication number and the mileage at which it is due should be written or stamped in their places. If this notice is used, the driver need only glance occasionally at the speedometer and compare the mileage on the dial with the figures on the notice in order to plan for the necessary attention.



Figure 19. The lubrication notice is a continual reminder of when the next lubrication is due.

Although this schedule is expressed in terms of miles, it is intended that the car be lubricated once each month if the mileage traveled is less than 1000 since the last lubrication operation was performed. This lubrication work can be done while the car is in the service station for its regular monthly or 1000-mile inspection.

Cadillac distributors and dealers are prepared to sell lubrication based on this schedule. A car that is being lubricated on the schedule can be taken to any authorized Cadillac-LaSalle service station, and without further ordering than to specify "Schedule Lubrication," the car will receive the necessary attention.

Lubrication Chart

The lubrication chart which accompanies this manual gives complete detailed instructions for lubricating the car. All of the points which require lubrication are designated on this chart, together with the kind of lubricant to be used, the method of applying it and the frequency with which it should be applied.

The operations are grouped on the chart in the same manner as on the schedule shown in Fig. 20. If the car is lubricated at an "Authorized Station," this schedule will be followed; if not, whoever does the lubrication should follow the schedule and chart exactly.

Lubricants

The selection of proper lubricants should be one of the first concerns of the owner in his attention to the lubrication of the car. The lubricants must not only be of high quality, but their viscosity and other characteristics must be suited to the car.

The owner is urged to consult the distributor or dealer from whom he purchased his car in regard to the names of lubricants which have been tested and approved for use in the Cadillac car.

Engine Oil

The chart of engine oil recommendations given on page 42 indicates the proper grades of oil to be used for average driving and for prolonged high speed driving.

Gear Lubricant

Lubricant conforming to the specifications for Gear Lubricant must be used in the transmission, rear axle and steering gear. It is particularly

important that only recommended lubricants be used in the transmission. Oil or soap greases will *not* perform satisfactorily.

Lubricants conforming to these specifications may be used without thinning during all weather, except winter weather below temperatures of 20° above zero. Below this temperature, thinning with kerosene is necessary, in order to secure easier gear shifting and proper lubrication of gears and bearings.

Chassis Grease

Lubricant conforming to the specifications for Chassis Grease is recommended for all chassis points fitted with grease gun connections. Do not use ordinary cup grease, as such greases are not effective enough to lubricate satisfactorily over the 1000-mile interval.

ENGINE OIL RECOMMENDATIONS

TYPE OF SERVICE	SUMMER	WINTER		
	All temperatures above 32° F.	Between 32° and 15° above	Between 15° above and 15° below zero	Below 15° below zero
AVERAGE DRIVING (No prolonged high speed driving)	*S. A. E. visc. 40 or 50	S. A. E. visc. 20	S. A. E. visc. 10 or S. A. E. visc. 20 thinned with 1 qt. kerosene to 7 qts. oil	S. A. E. visc. 10 thinned with 1 qt. kerosene to 7 qts. oil or S. A. E. visc. 20 thinned with 2 qts. kerosene to 6 qts. oil
	These oils are not suitable for prolonged high speed driving. Change to oil shown below before starting on long trip at speeds above 45 m. p. h.			
PROLONGED HIGH SPEED DRIVING.	CADILLAC APPROVED "HEAVY DUTY" OILS—SUMMER AND WINTER			
	These are oils having an S. A. E. viscosity of 50-60 which are required to meet certain specifications as to volatility in order to demonstrate their fitness for prolonged high speed driving. To make certain of using an oil approved for this service, consult your Cadillac distributor or dealer.			
	NOTE: Approved lubricants vary in their suitability for winter use. If an oil with a high pour test is used in winter and the car is not kept in a heated garage, add from 1 to 2 quarts of kerosene after a long drive at high speed before the car is stored for the night. Also when draining the crankcase, add from 1 to 2 quarts of kerosene to the fresh oil unless starting immediately on a long trip at high speed.			

*The system used in this table to designate body or viscosity is the one recently developed by the Society of Automotive Engineers and adopted by all oil companies. It takes the place of the old indefinite method of describing oils as "Light," "Medium," "Heavy," etc. Oil should be called for by these numbers. If a filling station attendant does not know the S. A. E. numbers of his oils, the following grades can be substituted in emergency; S. A. E. 10, Extra Light; S. A. E. 20, Light; S. A. E. 40, Heavy; S. A. E. 50-60, Extra Heavy.

Wheel Bearing and Cup Grease

Greases approved under the specifications for Wheel Bearing and Cup Grease are suitable for lubricating the wheel bearings, the clutch release bearing and the water pump.

This grease is not recommended for chassis lubrication, as Chassis Grease is much more effective.

Engine Lubrication

The supply of oil is carried in the pressed steel reservoir that covers the bottom of the crankcase. The oil is circulated by a gear pump inside of the crankcase. The pump is driven by a vertical shaft, which is, in turn, driven by a spiral gear on the camshaft. The oil circulated by the pump lubricates the main and connecting rod bearings, the camshaft bearings, the cylinder walls, pistons and piston pins, the front end chains, the valve mechanism, and the fan.

There are a few points on the engine that are not taken care of in the pressure system. These are the starter, generator and distributor oil cups, and the water pump. Lubricating instructions for these points are given in the lubrication chart.

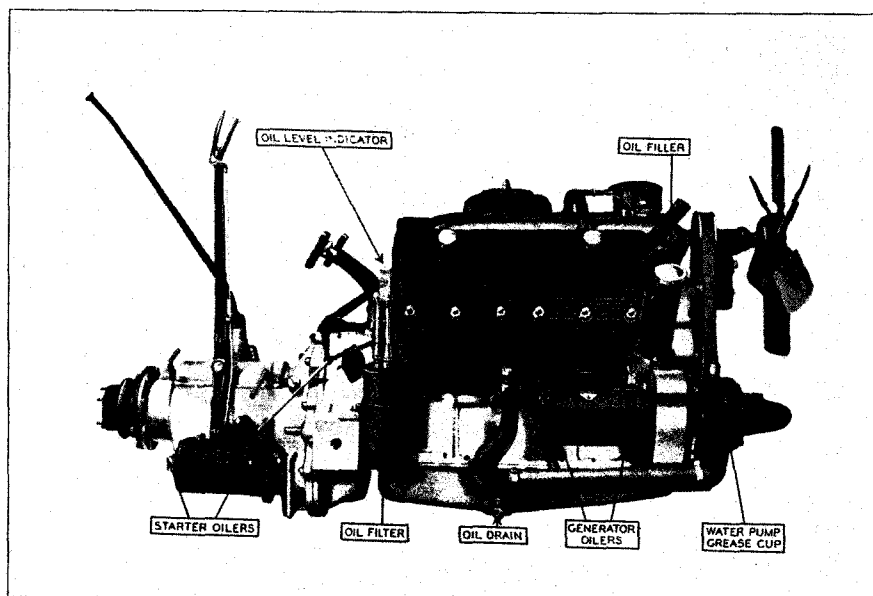

Figure 21. Showing the location of the oil filter, oil level indicator, oil pan drain plug and other lubrication features.

Oil Level

The normal capacity of the oil pan is two gallons, which fills it to the level of the screen in the pan. When the oil pan contains this amount, the oil level indicator on the right-hand side of the engine (Fig. 21) indicates "Full." As the oil level descends, the indicator indicates "Fill" and then "MT" (Empty). Oil should be added as soon as the indicator ball has dropped to "Fill." If the indicator indicates "MT," under no circumstances should the engine be run until oil has been added.

The mileage interval at which oil must be added depends upon individual circumstances. It is recommended that the oil level indicator be checked every one hundred to one hundred and fifty miles, although it is improbable that oil will be required as frequently as this.

Crankcase Ventilating System and Oil Filter

Cadillac engines are equipped with a crankcase ventilating system, which prevents contaminating of the lubricating oil from seepage vapors; and an oil filter, which removes any dirt or solid matter from the oil.

The crankcase ventilating system is entirely automatic and functions throughout the life of the car without requiring any attention from the owner. The oil filter, however, gradually becomes filled with the solid matter taken from the oil until it becomes so clogged that it ceases to function. For this reason, it is necessary to replace the filter cartridge every 12,000 miles.

The oil pan and screen should be removed and cleaned with kerosene or gasoline whenever the oil filter cartridge is replaced.

It is important that the filter cartridge be replaced just as soon as the 12,000 miles are up. Otherwise the whole purpose of the oil filter is defeated, and wear of the engine parts will result from the dirty oil. Filter cartridges for replacement can be obtained from Cadillac distributors and dealers or from United Motors Service stations.

Replacing Engine Oil

Although the crankcase ventilating system and the oil filter described in the preceding section greatly prolong the useful life of the oil, it is recommended that the oil be drained and replaced with fresh oil every 2000 miles.

To drain the oil, simply remove the drain plug (Fig. 21). Be sure to reinstall the drain plug before adding the fresh oil. Two gallons of fresh oil should be added, or enough to bring the oil level indicator ball to "Full."

CHAPTER V

Cold Weather Operation

THE Cadillac is an all-season car, and no owner need hesitate to make full use of his car in severe winter weather, as well as at other times. Satisfactory operation in freezing weather, however, depends upon having the car prepared for cold weather and in giving it the special attention which is required at that time. In this chapter has been grouped all the information relating to care and operation of the car during cold weather. It should be reviewed just prior to the beginning of the winter season.

Preparing for Cold Weather

Anti-Freezing Solutions

The available commercial materials for preparing anti-freezing solutions for automobile radiators are denatured alcohol, distilled glycerine, and ethylene glycol.

Denatured alcohol solutions are, at present, the most generally used anti-freezing solutions. Denatured alcohol is widely distributed, affords protection against freezing, and is not injurious to the materials used in the cooling system.

There are two principal objections to denatured alcohol. Alcohol is lost by evaporation, especially on heavy runs, and unless the solution is tested periodically and sufficient alcohol added to replace the loss by evaporation, the engine or radiator, or both, are likely to be damaged by freezing.

The car finish is damaged by contact with the alcohol solution or vapors from the solution. Any alcohol accidentally spilled on the finish should be flushed off immediately with a large quantity of water.

The following table gives the freezing temperature and specific gravity of solutions of denatured alcohol and water:

Lowest Temperature Expected	Per cent by Volume	Specific Gravity (at 60° F)	Qts. Alcohol required to make 6 gals. solution
10° F.	30	.9668	7 $\frac{1}{4}$
0° F.	38	.9567	9 $\frac{1}{4}$
-10° F.	45	.9475	10 $\frac{3}{4}$
-20° F.	51	.9350	12
-30° F.	57	.9260	13 $\frac{3}{4}$

(40)

Distilled glycerine and ethylene glycol solutions are, in first cost, more expensive than alcohol, but as they are not lost by evaporation, only water need be added to replace evaporation losses, except that any solution lost mechanically, such as leakage, foaming, etc., must be replaced by additional new anti-freezing solution. These solutions under ordinary conditions are not injurious to the car finish.

The principal objections to glycerine and ethylene glycol are the tendency of these solutions to loosen the scale and iron rust which forms in the water passages of the cylinder block and head, and the difficulty of securing and maintaining tight, leakproof connections. It is absolutely necessary to thoroughly clean and flush the entire cooling system before glycerine or ethylene glycol is used.

It is also necessary to tighten or replace the cylinder head gaskets and pump packing. The cylinder head gaskets must be kept tight to prevent the solution from leaking into the crankcase where it might cause gumming and sticking of the moving parts. The pump packing must be kept tight to prevent air from being drawn into the cooling system in order to avoid foaming and other difficulties which may result when air is present.

Glycerine or ethylene glycol should be used in accordance with the instructions and in the proportions recommended by the anti-freeze manufacturer.

In using a hydrometer to determine the temperature at which a solution will freeze, the test must be made at the temperature at which the hydrometer is calibrated. If the solution is warmer or colder, it must be brought to this temperature or large errors may result. In some cases these errors may be as large as 30 degrees Fahrenheit.

Salt solutions, such as calcium or magnesium chloride, sodium silicate, etc., honey, glucose and sugar solutions and oils are not satisfactory for use in automobile radiators.

Capacity of Cooling System

The capacity of the cooling system is six gallons when filled to the proper level. It is not necessary to add liquid to the radiator whenever the level falls below the filler. There is sufficient liquid in the cooling system if the upper tank is half-full, and any liquid in excess of this is usually forced out through the overflow pipe as soon as the engine becomes warm. When water is used, any loss from this cause is of little consequence, but in winter, to conserve anti-freeze, it is important to avoid adding more liquid than is necessary.

Winter Lubrication

Lubrication of the car requires special attention in winter, not only to insure proper lubrication of the moving parts, but to secure the same ease of operation in starting, steering and shifting gears as during warm weather.

The chart of engine oil recommendations on page 37 gives the proper grade of oil to be used for cold weather driving. It will be noted that lighter oils can be used for cold weather providing no prolonged high speed driving is done. For prolonged high speed driving, "Heavy duty" oils must be used. Authorized Cadillac-La Salle Service Stations are prepared with full information on winter lubrication.

The lubricant in the transmission and rear axle should also be thinned as soon as the weather is so cold that the transmission gears are hard to shift. If a sufficient amount of kerosene is added to provide for the lowest winter temperature expected, it will not be necessary to add kerosene again thereafter during the winter. If ten per cent kerosene is added, this will take care of temperatures down to ten below zero.

Storage Battery

The electrical system of an automobile has much more to do in winter than in summer. The engine is harder to crank and must usually be cranked longer before it starts. The lights are also used to a much greater extent than during the long days of summer. All this means that the battery must be ready for increased demands.

It is therefore a good plan in preparing for the winter season to see that the battery is well charged to begin with, that the battery connections are clean and tight, and that the charging rate of the generator is sufficient.

Gasoline System

The carburetor on the Cadillac engine has automatic compensation for temperature. Nevertheless it is a good plan to have the carburetor adjustment checked when cold weather arrives. This inspection should give special attention to the carburetor choke control to make sure that the enriching device at the carburetor is fully effective when the choke button is operated.

In warm weather, a small amount of water in the gasoline has little or no effect on the running of the engine. In freezing weather, however, even a small amount of water may freeze and stop the entire flow of fuel to the

carburetor. One of the things to be done in preparing for winter weather, therefore, is to clean the gasoline filter and the sediment chambers in the gasoline system.

Starting the Engine

Carburetor Enriching Button

The first difference between starting the engine in cold weather and starting the engine in warm weather is in the greater use of the carburetor enriching device necessary in cold weather. Gasoline does not vaporize as readily at low temperatures, and in order to supply the cylinders with a gaseous mixture rich enough to be ignited, the proportion of liquid gasoline to air must be increased.

At the same time, it is important not to apply the enriching device more than is necessary. The unvaporized gasoline collects on the cylinder walls and works down past the pistons, washing off the lubricant as it goes. Although dilution of the oil supply with this unburned gasoline is minimized by the crankcase ventilating system, it is best to avoid an excess of liquid gasoline in the combustion chambers by careful and judicious use of the enriching device.

The following rule should govern the use of the enriching button in winter weather: Pull the enriching button back just as far as it is necessary to start the engine, but as soon as the engine starts, let the button return as far as possible without causing the engine to stop or slow down. Then release the button entirely as soon as the engine is warm enough to permit doing so.

Priming the Carburetor

In extremely cold weather, if the engine does not start after cranking for a few seconds with the enriching device fully applied, release the starter pedal. Then prime the carburetor by opening and closing the throttle once or twice rather rapidly with the accelerator. Opening and closing the throttle operates a throttle pump on the carburetor and raises the level of the gasoline in the carburetor bowl. The carburetor should never be primed in warm weather and should not be primed unnecessarily in cold weather. Excessive priming is likely to make starting difficult rather than easy.

Position of Throttle Hand Lever

The correct position of the throttle hand lever for starting in cold weather is the same as for starting under other conditions, that is, about one-fourth

the way down from the idling position. In warm weather, however, the lever may be returned to the idling position almost as soon as the engine is started. In cold weather, the throttle must be left slightly open until the engine becomes warm.

Position of Spark Control Lever

It is the practice of some drivers to move the spark control lever all the way to "retard," whenever starting the engine. This is the correct position if the engine is to be cranked by hand, but if the engine is to be cranked with the starter, the spark lever should be set in the "Starting" or fully advanced position.

Use of Starter

In extremely cold weather, when the car has been standing long enough to become thoroughly chilled, it is a good plan to disengage the clutch during the cranking operation. If this is not done, the starter is called upon to turn the jackshaft gears in the transmission in addition to cranking the engine. At ordinary temperatures, the additional energy required is negligible, but in extremely cold weather, the lubricant in the transmission offers sufficient resistance to rotation of the transmission gears to increase considerably the demand upon the battery and to retard the cranking speed.

Use of Accelerator Before Engine Is Warm

In cold weather, after the engine has been started and before it has run long enough to become warm, the engine cannot deliver its normal power, and it should not be called upon to do so. In accelerating the engine to start the car and in accelerating the car after the transmission is in gear, do not open the throttle suddenly or too far. To do so is not only to invite "popping back" in the carburetor, but to increase the amount of excess unvaporized gasoline in the combustion chambers, both of which results are undesirable. For this reason, also, starting in intermediate should never be attempted when the engine is cold.

CHAPTER VI

General Care

No attempt has been made to include in this manual directions for making adjustments or repairs to the car. Most Cadillac owners prefer to depend for such work on authorized Cadillac-La Salle service stations, as these stations can invariably perform the work more conveniently and economically.

Every owner should, however, know how to perform the few simple operations of general care described in this chapter. These operations are not difficult enough to necessitate a visit to the service station, although this work can also be done in the service station, if desired.

Storage Battery

The storage battery is carried in a compartment between the right-hand running board and the frame. The door of the compartment operates the same as the door of the tool compartment, described on page 27.

The battery is filled with an acid solution from which the water slowly evaporates, and fresh distilled water must be added to each of the three cells at regular intervals to bring the level up to the bottom of the filling tubes. Distilled water should be added at least every 1000 miles, and in warm weather, every 500 miles, or at least every two weeks. If distilled water is not available, melted artificial ice or rain water caught in an earthenware receptacle may be used. Hydrant water or water that has been in contact with metallic surfaces will cause trouble if used. Acid must never be added to the battery.

After adding water to the storage battery in freezing weather, the car should immediately be run far enough to mix the water and acid solution thoroughly. If the car is parked immediately after adding water, the water is likely to stay on top of the acid solution and may freeze, causing extensive damage.

As the storage battery is charged and discharged, the solution reacts chemically with the plates of the battery, the specific gravity of the solution changing as the reaction proceeds. The state of charge of the battery

is thus indicated by the specific gravity of the solution. As the battery is charged, the specific gravity of the solution increases, reaching 1.270 to 1.285 when the battery is fully charged. The specific gravity of the solution decreases as the battery is discharged. A fully discharged battery has a specific gravity of 1.150 to 1.165.

A hydrometer is the instrument used to measure the specific gravity of a solution. A hydrometer syringe is a hydrometer especially designed for convenience in testing the specific gravity of the acid solution in the storage battery. A hydrometer syringe can be obtained at any battery service station. Be sure and get a reliable instrument, for cheap ones may be in error as much as 25 or 30 points.

The specific gravity of the acid solution should never be tested immediately after adding distilled water. If the solution is below the plates, so that it cannot be reached with the syringe, add the necessary amount of water, then drive the car for a few hours before taking the hydrometer reading.

The battery is made by the Electric Storage Battery Company, whose general offices and works are at Alleghany Avenue and Nineteenth Street, Philadelphia. This company has representative stations in many towns, as well as sales offices and Exide battery depots in a number of the larger cities. If a storage battery is in need of attention other than recharging, it is advisable to communicate either with a Cadillac service station or with the nearest Exide station or depot.

Cooling System

The cooling system should be kept filled with 6 gallons of water, except in freezing weather, when a suitable anti-freezing solution, such as those described on page 40, must be used.

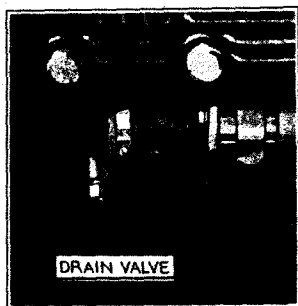

Fig. 22. The entire cooling system can be drained by opening this one valve.

The drain valve for the cooling system is in the water inlet elbow on the right side of the crankcase just back of the generator.

The cooling system should be drained and flushed every 4000 miles. If possible, this should be done at a Cadillac service station, or where there are facilities for reversing the flow of water through the radiator. If this is not possible, use the following method:

Run the engine until the opening of the radiator shutters indicates that the engine is warm. Stop the engine and immediately open the drain valve.

After the liquid has drained off, refill the cooling system with hot water and repeat the operation described above. If, in draining the second time, the water is very dirty, it may be advisable to repeat the flushing operation a third time, placing one or two handfuls of sal-soda in through the radiator filler. The sal-soda must not be permitted to get on the finish of the hood or radiator. If sal-soda is used, the cooling system must be drained and flushed again before refilling for use.

Gasoline Filter

A gasoline filter (Fig. 23) is provided in the gasoline line between the vacuum tank and the carburetor. This filter has a glass bowl through which the accumulation of water and sediment can be easily seen. The bowl should be removed and the gauze screen should be cleaned, as soon as any accumulation appears in the bowl. This can be done as follows:

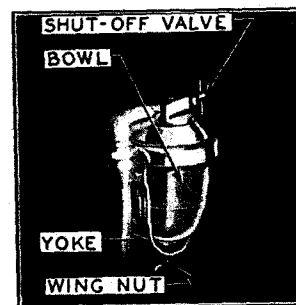

Figure 23. To remove the filter bowl for cleaning the screen, close the shut-off valve, loosen the wing nut at the bottom and disengage the supporting yoke.

First shut off the gasoline by turning clockwise the small T-handle valve at the side of the filter. Then unscrew the thumb screw under the bowl, after which the yoke supporting the bowl can be swung to one side and the bowl can be removed. If the screen does not come off with the bowl, it can be removed by pulling it straight down.

In putting back the bowl, make sure that it seats properly against the cork gasket in the top of the filter before tightening the thumb screw. Do not forget to turn the gasoline on by turning the valve counter-clockwise as far as it will go.

There is also a strainer in the vacuum tank at the point where the gasoline enters the inner chamber. The strainer should be removed and cleaned occasionally. The strainer is accessible after disconnecting the feed pipe and unscrewing the inlet elbow.

Temporary Brake Adjustment

It is recommended that all adjustment of the brakes be done at an authorized Cadillac-La Salle service station. In an emergency, however, the following temporary adjustment can be made by the driver.

Each brake is fitted with an adjusting nut on the cam lever, as shown in Fig. 24. To tighten the brake adjustment turn all four adjusting nuts half a turn clockwise. These adjusting nuts lock each sixth of a turn.

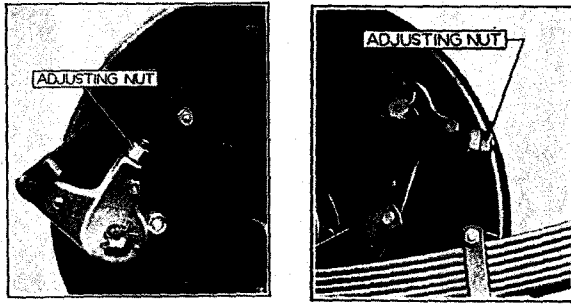

Fig. 24. A temporary brake adjustment can be secured by turning the adjusting nut on each brake clockwise $\frac{1}{2}$ turn. The front brake is at the left, the rear brake at the right.

Body

Care of Finish

The Duco finish of Cadillac bodies can be kept new and lustrous with the simplest care. The car should merely be wiped off every few days with a soft dry cloth. An occasional polishing with some recognized Duco polish, such as Cadillac I-sis (for sale by all Cadillac distributors and dealers) will prove beneficial.

If the finish is cared for by being wiped at regular intervals, it will not need to be washed, except when it has accumulated a considerable amount of mud or dust. When washing the car, use plenty of clean cold water. Do not use hot water, and do not wash the hood while it is hot, as this will in time destroy the luster. Do not use soap.

If a hose is used in washing, do not use a nozzle, but let the water flow gently from the hose and flush off the dirt gradually. A soft wool sponge can be used to advantage in removing dirt.

After the washing is completed, squeeze the sponge as dry as possible and pick up all water from crevices. Then thoroughly wet a clean soft chamois, wring it as dry as possible and dry the finish. The finish can then be rubbed with a clean soft cloth to bring out the luster.

Care of the Top

Ordinary dust can be removed from the top with a soft dry cloth. Grease spots, stains and dirt film can be removed by washing with a mild, neutral soap. Rinse thoroughly with clear water to remove all traces of the soap, then dry with a chamois or cloth. Gasoline, naphtha, kerosene and fabric cleaners should not be used for cleaning the top, as such preparations are likely to dull the luster and damage the fabric, causing leaks.

Cleaning Upholstery

To keep the upholstery in closed cars in the best condition, it should be cleaned thoroughly at least once a month with a whisk broom and vacuum cleaner. Dirt and grit accumulating in the fabric wear it out faster than use.

Spots on the upholstery may be cleaned with any good dry cleaner. When the cleaner has thoroughly evaporated, apply a hot flatiron wrapped in a wet cloth. Steaming the fabric and rubbing lightly against the nap will raise the nap to its normal position.

Door Hardware

Many owners who give careful attention to lubrication of the chassis do not give the same attention to the lubrication of door locks and hinges. If the door hardware is to operate properly, it must be lubricated regularly. Directions for this lubrication are included in the lubrication chart, and these directions should be followed as faithfully as the rest of the chart.

CHAPTER VII

Storing Car

IF THE car is not to be used for a period of several months, it should be protected from deterioration during the period when it is not in use by carefully preparing it for storage.

Engine

To prepare the engine for storage, proceed as follows: Run the engine until opening of the radiator shutters indicates that the engine is warm. This may be done by driving on the road or by running the engine idle. In the latter case, care should be taken that there is sufficient ventilation to avoid injury from carbon monoxide poisoning. (See page 21.)

After the engine is warm, place the car where it is to be stored and shut off the flow of gasoline to the carburetor by turning the valve above the filter. As soon as the engine starts to slow down, raise the polished aluminum cap on top of the carburetor and inject three or four tablespoonfuls of clean fresh engine oil into the carburetor. Injection of the oil will stop the engine.

Remove the spark plugs. Inject two or three tablespoonfuls of engine oil into each spark plug hole, and before replacing the plugs, crank the engine three or four revolutions with the ignition switched off. This will tend to distribute the oil over the cylinder walls. The engine should not be started again after injecting the oil. If it is started, it will be necessary to repeat the treatment.

Drain the cooling system.

Storage Battery

If the car is to be stored during the winter, the storage battery should have special treatment in order to protect it against freezing.

Shortly before the car is used for the last time, distilled water should be added to bring the level of the solution up to the bottom of the filling tubes. (See page 45.) After the water added has had an opportunity to mix thoroughly with the acid solution by running the car or engine, the specific gravity should be taken with a hydrometer. If the specific gravity

of the solution is above 1.270, there will be no danger of the acid solution freezing. If, however, the specific gravity is below 1.270, the battery should be removed and charged. Unless the battery is fully charged, or nearly so, it is probable that the acid solution in the battery will freeze and cause extensive damage.

The battery ground connection should in all cases be disconnected during storage, as a slight leak in the wiring will discharge the battery and lower the specific gravity to the point where the solution may freeze.

If possible, the storage battery should be removed and charged from an outside source every two months during the storage period.

Tires

During the storage of the car, it is best to remove the tires from the rims and to keep the casings and tubes in a fairly warm atmosphere away from the light. The tubes should be inflated slightly after the tires have been removed.

If it is not convenient to remove the tires from the car, and the car is stored in a light place, cover the tires to protect them from strong light, which has a deteriorating effect on rubber.

The weight of the car should not be allowed to rest on tires during the storage period. If tires are not removed, the car should be blocked up, so that no weight is borne by the tires. The tires should also be partly deflated.

Body and Top

A cover should be placed over the entire car to protect it from dust. In storing an open car, the top should be up.

Taking Car Out of Storage

In putting into use again a car that has been stored, it is advisable, unless the storage battery has been removed and charged at periodic intervals, to remove the battery from the car and give it a fifty-hour charge at a four-ampere rate. If the battery has received periodic charges, or if the specific gravity is above 1.200, simply add distilled water to the proper level and connect the leads. If there is a greenish deposit on the terminals of the battery, remove this with a solution of bicarbonate of soda (common cooking soda) and water. Do not allow any of this solution to get into the battery.

Before starting the engine, drain the oil from the oil pan and remove and clean the oil pan and screen. After reinstalling the oil pan, add eight quarts of fresh engine oil. Fill the cooling system, being sure to use anti-freezing solution in freezing weather. Remove the spark plugs and inject two or three tablespoonfuls of engine oil into each cylinder. Reinstall the spark plugs and, with the ignition switched off, crank the engine a few seconds with the starter to distribute the oil over the cylinder walls.

Start the engine in the usual manner. As soon as the engine starts, immediately let the carburetor enriching button go as far forward as possible without causing the engine to stop or slow down materially, and then open the throttle until the ammeter reads approximately 10 with all lights switched off. While the engine is running, lift the aluminum cap on top of the carburetor and inject two or three tablespoonfuls of engine oil into the carburetor. It is a good plan to run the car outdoors as soon as this has been done. Release the carburetor enriching button entirely as soon as the engine is warm enough to permit it.

CHAPTER VIII

Specifications and License Data

Type of engine.....	8 cyl. V-type
Diameter of cylinder bore.....	3 $\frac{3}{8}$ in.
Length of stroke.....	4 $\frac{15}{16}$ in.
Piston displacement.....	353
Horsepower (N. A. C. C. rating).....	36.45
Engine number.....	See below
Capacity of gasoline tank.....	25 gals.
Capacity of engine lubricating system.....	2 gals.
Capacity of cooling system.....	6 gals.
Capacity of transmission.....	3 qts.
Capacity of rear axle.....	3 $\frac{1}{4}$ qts.
Wheelbase.....	140 in.
Tires.....	7.00-19
Valve setting, inlet.....	.004 in.
Valve setting, exhaust.....	.006 in.
Spark plug setting.....	.025-.028 in.
Contact point setting.....	.024 in.
Generator charging rate, maximum.....	} 18-20 amps. cold } 8-10 amps. hot
Fan belt slack.....	1 in.
Front axle toe-in.....	$\frac{1}{8}$ to $\frac{1}{4}$ in.

Engine and Unit Assembly Numbers

Each Cadillac car, when shipped, carries an engine number, which is also a serial number. This is the number to be used in filling out license and insurance applications and in general reference of the car. The engine number is stamped on the crankcase just below the water inlet on the right-hand side.

The various units, such as the transmission, steering gear, etc., also carry unit assembly numbers. These are located as described below. It is im-

portant in ordering parts to give, not only the engine number of the car, but also the unit assembly number of the unit to which the part belongs.

Transmission number—on the upper left-hand edge of the flange by which the transmission is bolted to the crankcase.

Steering gear number—on the steering gear housing, just below the grease plug.

Carburetor number—on right front face of the flange by which the carburetor is attached to the intake header.

Generator number—on the side of the generator just in front of the cut-out relay.

Starting motor number—on the right-hand side of the starter, just below the switch.

Front axle number—on the upper surface of the axle I-beam at the right-hand end just above the steering stop screw.

Rear axle number—on the rear surface of the axle housing just to the right of the cover plate.

Chassis (frame) number—on the upper surface of the left-hand side bar, just ahead of the steering gear.

INDEX

A		E	
Accelerator.....	11	Effect of alcohol on finish.....	40
Accelerator, use in cold weather.....	44	Engine fails to start.....	15
Adding water to battery.....	45	Engine knocks.....	12
Adjustable seat.....	24	Engine lubrication.....	38
Adjustments.....	6	Engine number.....	53
Air pump for tires.....	28	Engine oil.....	36
Alcohol for anti-freeze.....	40	Engine oil, changing.....	39
Ammeter.....	20	Engine oil, thinning.....	42
Anti-freeze solutions.....	40	Engine, preparing for storage.....	50
Authorized service stations.....	5	Engine, running in garage.....	21
B		Equipment.....	23
Balancing marks on tires.....	31	F	
Battery.....	45	Fenderwells.....	30
Battery, preparing for storage.....	50	Filter for gasoline.....	47
Body, care of.....	48	Filter for oil.....	39
Brake adjustment.....	48	Finish, care of.....	49
Brakes.....	19	Flat-rate service charges.....	6
C		Flooded carburetor.....	15
Cadillac service.....	5	Flushing cooling system.....	46
Carbon monoxide poisoning.....	21	Foot brakes.....	19
Carburetor enriching control.....	13, 43	G	
Carburetor flooded.....	15	Gasoline filter.....	47
Carburetor heat control.....	14	Gasoline gauge.....	9
Carburetor, to prime.....	43	Gasoline system, cold weather.....	42
Card, service.....	5	Gear lubricant.....	36
Care of car.....	7	General care.....	45
Changing engine oil.....	39	Glycerine for anti-freeze.....	40
Changing tires.....	31	Greases.....	37
Charging rate.....	20, 53	H	
Charges for service.....	6	Headlamps.....	21
Charr, lubrication.....	36	Heat control, carburetor.....	14
Chassis grease.....	37	Heat indicator.....	11
Choke button.....	13	High compression cylinder heads.....	12
Cigar lighter.....	24	I	
Cleaning car.....	48	Ignition control.....	12
Cleaning cooling system.....	46	Ignition control, cold weather.....	44
Cleaning upholstery.....	49	Ignition switch lock.....	9
Clutch pedal.....	16	Inflation pressure.....	28
Clutch, use of.....	16	Inspection lamp.....	24
Coasting.....	18	Inspections.....	8
Coincidental lock.....	9	J	
Cold weather lubrication.....	42	Jack, use of.....	30
Cold weather operation.....	40	K	
Compartment for tools.....	27	Keys.....	9
Cooling system.....	40, 46	"Knocking" in engine.....	12
Crankcase ventilating system.....	39	D	
Cylinder heads, high compression.....	12	Danger from carbon monoxide.....	21
D		Disc wheel carrier.....	29
Danger from carbon monoxide.....	21	Door hardware.....	49
Disc wheel carrier.....	29	Driver's seat adjustment.....	24
Door hardware.....	49	Driving speed when new.....	7
Driver's seat adjustment.....	24	Duco, care of.....	48
Driving speed when new.....	7	E	
Duco, care of.....	48	F	

L		Specific gravity of battery	45
License data	53	Speedometer	20
Lighting switch	21	Starting the engine	14
Locks	9	Starting the engine, fails to start	15
Locks for spare tires	30	Starting the engine, in cold weather	43
Lubricants	36	Storage battery	42, 45
Lubrication	7, 35	Storing car	50
Lubrication, charr.	36	Syncro-mesh transmission	17
Lubrication, cold weather	42	T	
Lubrication, door hardware	49	Temperature indicator	11
Lubrication, engine	38	Throttle control	11, 44
Lubrication, notice	35	Tire air compressor	28
Lubrication, schedule	35	Tire balancing marks	31
O		Tire carrier	29
Obligations of owner	7	Tire pressure	7, 28
Oil filter	39	Tire valve caps	28
Oil level	39	Tires, changing	31
Oil pressure	15	Tires, preparing for storage	51
Oil pressure gauge	15	Tools	25
Operation	9, 40	Top, care of	49
P		Tourists, service to	5
Parts, uniform prices	7	Transmission control	17
Preventive service	8	Transmission lock	9
Priming carburetor	43	Truing up rim	30
Priming		U	
Repairs		Upright assembly numbers	53
Replacing engine oil		Upright, care of	49
Replacing filter cartridge		Upright, accelerator before engine is warm	44
Rim, truing up		Upright, jack	30
S		V	
Schedule lubrication	35	Vacuum tank, priming	15
Sealing compound		Valve caps	28
Sealing		Ventilators	23
Service station	6	W	
Shifting gear	5	Washing car	48
Spare tire		Wheel bearing grease	38
Sparking plug		Windshield	23
Sparking plug, winter lubrication		Windshield cleaner	24
Sparking plug, winter operation		Winter lubrication	42
Sparking plug, wire wheel carrier		Winter operation	40
Sparking plug, wire wheel carrier		Wire wheel carrier	29

Date Due

JUL 30 1954

JL

