

MASTER CYLINDER—SERIES 1946 thru 1955; 1957

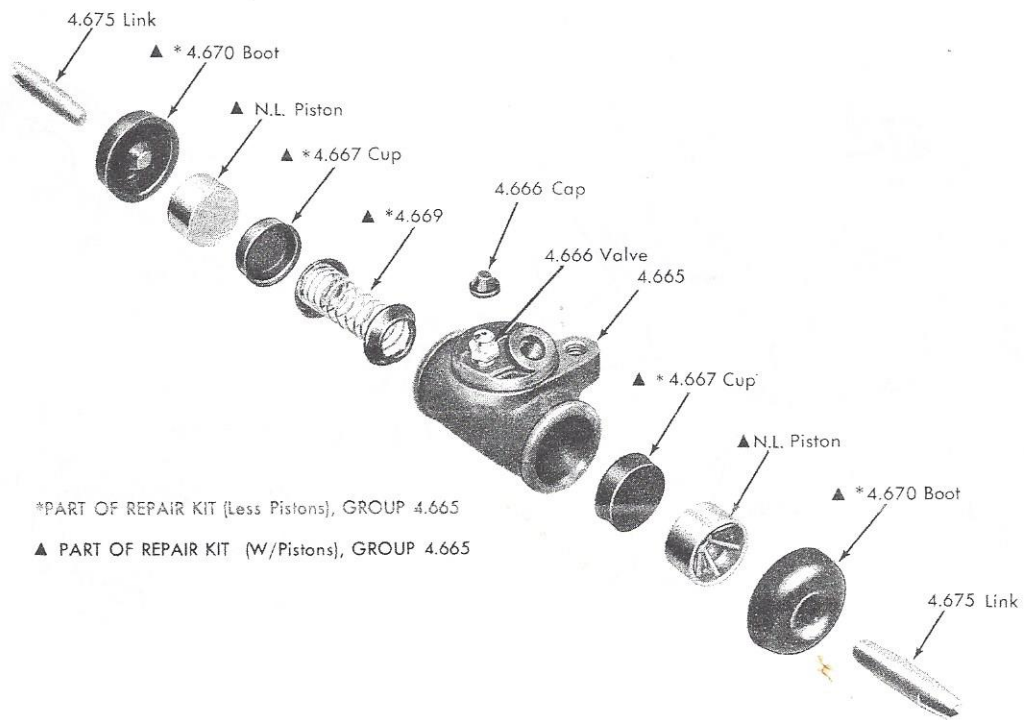

WHEEL CYLINDER—SERIES 1946 thru 1965